

makkar **IELTS**

English for Exams

**20**  
READINGS

# IELTS

## ACADEMIC READINGS FOR EXAM PRACTICE

---

Dr. Kiranpreet Kaur Makkar

## IELTS ACADEMIC READINGS FOR KIRAN'S IELTS CENTRE

### Reading 1

#### The world is our oyster

- A. Independent travel is on the increase and while package holidays which offer an all inclusive price for transport, accommodation and often even food are financially attractive to many, according to tourism analyst Thomas Cooper, an increasing number of people now prefer a less-tailored holiday and the freedom to make spur of the moment decisions and changes to their intended plan.
- B. Internet based information sites about backpacking destinations are prolific and publications aimed at independent travellers on a budget exist for almost every destination imaginable. Some people, particularly first-time backpackers, may elect to travel with a friend or acquaintance; however, a large percentage of backpackers travel alone, assured by the knowledge that they are likely to meet, with ease, a number of like-minded individuals throughout their journey and staying in their backpacker accommodation. Alan Park, who has travelled extensively through Europe, Australasia and several other parts of the globe, says most accommodation establishments aimed at the backpacker market are designed with communal kitchens, dormitories and entertainment areas which lend themselves to allowing residents to socialize with ease and quickly breakdown barriers with strangers that may usually exist in day to day life.
- C. Many backpackers of European origin are attracted to the Southern Hemisphere, Australia being a major destination of choice. Cooper attributes this high level of interest to the possibilities of legal working holiday visas for many nationalities and consequent short-term work opportunities making extended travel financially feasible, in addition to the attractive climate and outback appeal. Australia also has the reputation of being a relatively safe destination, with a warm and jovial population and its size and contrast between locations is alluring to many. University student Rebecca Thompson, who has just returned from a twelve month overseas trip, says that the cosmopolitan and modern nature of Australian cities such as Sydney and Melbourne contrasted with the rugged outback appeal of Western Australia and the Northern Territory, or the marine paradise of the Great Barrier Reef offer sufficient variation to attract a wide base of visitors. Sydney based travel consultant Brad Connor advises that it is also possible to obtain bargain deals on internal flights within this massive island when purchasing an international ticket, highly recommended, he says, for those who do not have the luxury of a long length of time, in order to ensure that key spots can be visited.
- D. Equal in popularity to Australia, for the backpacking market is South East Asia and Rebecca Thompson says that, in her experience, the majority of travellers on extended trips to Australasia also include a visit to one or more South East Asia destinations in their itinerary. Thailand, in particular, has a long tourism history and well-established service industry. It is often considered one of the more accessible Asian destinations for the novice European backpacker due to its reasonable prices, large volume of Western visitors and well established backpacker trails. Brian Johnson, who is currently employed by the British Consulate in Bangkok, believes that the welcoming nature and level of English spoken by Thais involved in the tourism industry has also impacted positively on the destination's overseas image. Thai food is delicious and now fairly familiar to those outside the country and while precautions such as drinking bottled water and washing of fruit and vegetables should be practiced, generally standards of accommodation and restaurants are high. Thomas Cooper says Thailand's attractions are wide ranging, encompassing idyllic beaches, an insight into Buddhist culture and impressive ancient temples, mountain trekking, a vibrant nightlife and for bargain hunters bustling night markets and bazaars.
- E. South East Asia neighbour, Vietnam, alongside its rapidly developing economy has also over recent years established a solid tourism industry, the majority of visitors entering and exiting by plane via its urban centres Ho Chi Minh (formerly Saigon) in the south and Hanoi in the

north. Vietnam offers incredible vistas and contrasts of rugged mountain areas, lush green rice paddies, crystal clear waters and dense forest areas. Alan Park, who spent a month travelling independently around the country, says bus and rail networks allow visitors to travel from centre to centre relatively inexpensively, though he does not recommend these forms of transport to visitors on a short time-frame as the pace is unhurried.

- F. The list of potentially safe and enjoyable backpacking destinations is endless. Technology and transport developments over recent time have resulted in more areas of the world becoming increasingly accessible, it is now possible to keep in regular contact with friends and family back home via email or even mobile phone, providing added reassurance to those concerned about travelling and their worried parents. Brian Johnson says friends, family and acquaintances who have previously travelled to the destination of choice are a useful source of first-hand advice and information and Simon Hartwell of the Backpackers Association adds travellers are advised to ensure that they are aware of visa requirements for their destination and are urged to seek medical advice regarding any necessary vaccinations or medical precautions. It is always wise to be as well informed as possible prior to embarking on a trip.
- G. The youth of today are undoubtedly becoming more adventurous, which Hartwell ascribes to higher disposable income in the developed world than were available to previous generations and also the fact that we can more easily familiarise ourselves with the unknown via the internet and other communication methods. Many travellers, particularly experienced backpackers, are keen to experience more obscure destinations well off the well-trodden backpacker trail.

#### Questions 1 - 4

Match each statement with the correct person. Write the correct answer A-D in boxes 1-4 on your answer sheet

1. Opportunities to fund expenses through casual work increase the volume of visitors to a particular destination.
2. Attitude to the tourism industry of the local people has had a positive impact on visitor numbers
3. Diverse attractions mean a destination is able to appeal to a wider range of people
4. Motivations for different approaches to travel by different generations

#### List of People

- A. Simon Hartwell
- B. Brian Johnson
- C. Thomas Cooper
- D. Rebecca Thompson

#### Questions 5-8

Do the following statements agree with the views given in Reading Passage. Write

YES *if the statement agrees with the views given*

NO *if the statement contradicts the views given*

NOT GIVEN *if it is impossible to say*

5. Interaction with others is generally more difficult when travelling alone than in normal life situations.
6. Travelling by plane to other domestic destinations in Australia is cheaper than other forms of transport.
7. Train travel in Vietnam can be too time-consuming for short visits.
8. Experienced backpackers rarely travel to destinations such as Australia.

#### Questions 9-11

Complete the notes below. Choose **NO MORE THAN TWO WORDS** from the passage for each answer. Write your answers in boxes 9-11 on your answer sheet.

Vietnam - tourism industry growing as is its (9) \_\_\_\_\_.

Thailand - certain (10) \_\_\_\_\_ are advisable - e.g. wash fruit

Australia - Great Barrier Reef can be described as a (11) \_\_\_\_\_.

## Reading Passage 2

**An Aviation Wonder and its Creator**

- A. The Supermarine Spitfire was a single-seater fighter plane used by the British Royal Airforce and pilots from a number of the country's allies during the Second World War. The first flight of a Spitfire prototype was on 5 March 1936 and usage of the plane continued until the 1950s. It was said to be one of the most effective fighter planes available during that period and was produced by Vickers-Armstrongs, a British engineering corporation which was formed in 1927 as a result of the merger of Vickers Limited and Sir W G Armstrong Whitworth & Company.
- B. The Spitfire was designed by aeronautical engineer Reginald Joseph Mitchell. His career began when he joined a locomotives engineering company in 1911 at the age of 16. However, in 1917 he moved from his home town to join the Supermarine Aviation works in Southampton and was promoted to Chief Designer within his first year of employment. By the time the company was taken over by Vickers-Armstrongs in 1928, Mitchell had held the post of Technical Director for a year; and his capabilities and contributions were deemed so significant Vickers-Armstrong made his continual employment for a five year period a condition of the purchase of the company.
- C. In the fifteen years prior to 1936 Mitchell designed 24 aircraft of differing categories including fighter planes, bombers and seaplanes. The first predecessor of the Spitfire in the fighter plane category to gain him national acclaim was the Supermarine S.B for which he won the Schneider Trophy (a cup and monetary award for technical advances in aviation which came to focus mainly on speed) in 1931. Despite withdrawal of financial support from the British Government that year, the Supermarine S.B. was able to compete for the Schneider Trophy as a result of a private donation of 100,000 pounds. Mitchell's team won outright on September 13<sup>th</sup> their aircraft achieving a new world speed record of 606 km/h; within days the Supermarine S.B. went on to break its own newly achieved record when on the 29<sup>th</sup> of the same month it became the first aircraft ever to achieve speeds of over 400 miles per hour (640 kilometres) when it reached 407.5 mph (640 kilometres per hour).
- D. Reginald Joseph Mitchell was awarded a CBE in 1932 for his contributions to high speed flight. CBEs being awarded by the British Monarch and reserved to recognise individuals who have 'fulfilled a conspicuous leading role in regional affairs, through achievement or service to the community, or making a highly distinguished, innovative contribution in his or her area of activity'. Mitchell's achievements with the Supermarine S.B. also prompted the Air Ministry to contract his company for design of a new fighter aircraft, despite the organisation's reputation being built predominantly on sea-plane and not fighter plane manufacturing.
- E. The first type, the 224, was to prove unsuccessful and it was eventually rejected by the Royal Air Force due to unsatisfactory performance; however, private sponsorship enabled research, development and modifications which led to the creation of the Type 300 which would eventually become the Spitfire. Soon after the first flight of the Spitfire prototype (trial version) and prior to completion of all stages of its official trials, convinced by its potential, the British Royal Air Force ordered 310 models. With its smooth lines, load-bearing metal shell, and heavy eight-machine gun armament, the Spitfire was considered revolutionary. In 1938, the aircraft was first put into official service; however, Mitchell, who died from cancer in 1937 at the age of 42, was not to witness this or the extensive impact and longevity of use the aircraft would have. In total 20,351 spitfires of different versions were produced making it the most produced British aircraft of the Second World War.
- F. After Mitchell's death, his former Chief Draughtsman Joe Smith took over the position of Technical Director and led the subsequent development of the Spitfire which would keep it at the forefront of aircraft technology while many other designs quickly became obsolete; 24 models of spitfire were designed along with many sub-variants containing different engine types and possessing different wing configurations; the most widely used being the Spitfire Mark V, of which 6,479 were built. The original version first used for active service in 1938 had a top speed of approximately 580 km per hour; while one of the last models used in the later stages of the Second World War - the Spitfire XIV - had a top speed capability of 710 km per hour. Spitfires were used continually by the Royal Air Force, later purely as surveillance planes (to monitor activity overhead though carrying no armament), until 1954 when the last model was retired.

- G. In his home town, Reginald Joseph Mitchell C.B.E. is today remembered in a number of ways. A combined theatre and education centre 'The Mitchell Memorial Theatre' bears his name, and the city museum, at the entrance of which stands a bronze statue of Mitchell, displays an authentic and complete Spitfire as part of its collection. In addition, a local high school is named after him; as is a major roadway and he is locally recognised as one of the most significant historical sons of the town.

#### Questions 12-17

Complete the flowchart below. Choose **NO MORE THAN TWO WORDS** from the passage for each answer. Write your answers in boxes 12 and 17 on your answer sheet

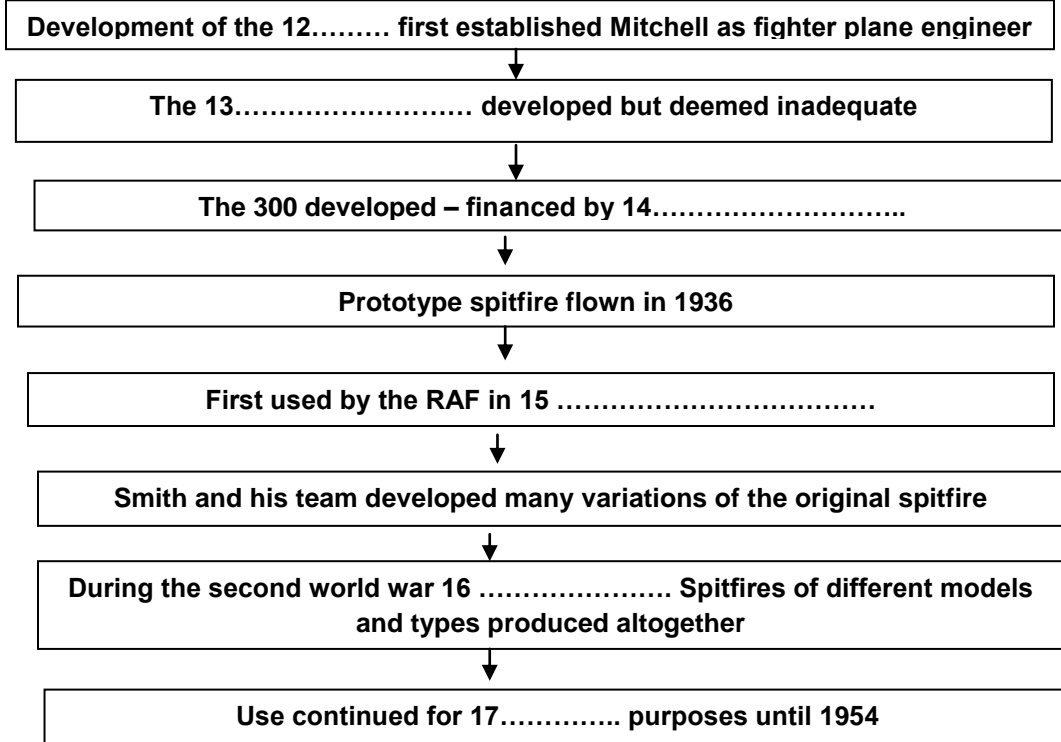

#### Questions 18-20

According to the information in the passage, classify the following information as relating to:

- (a) the Supermarine SB  
 (b) the Spitfire  
 (c) neither the Supermarine SB or the Spitfire  
 (d) both the Supermarine SB and the Spitfire

Write the correct letter, A, B or C in boxes 18-20 on your answer sheet

18. Its development was commissioned by the Air Ministry  
 19. Mitchell was awarded the CBE due to its development.  
 20. It was innovative for its time

#### Questions 21-25

Reading Passage 2 has seven paragraphs A-G. Which paragraph contains the following information? Write the correct letter A-G in boxes 21-25 on your answer sheet. NB You may use any letter more than once.

21. Where the Royal Air Force showed faith in Mitchell's engineering capability without complete evidence.  
 22. Where Mitchell's involvement influenced a business purchase  
 23 How Mitchell has been honoured since his death.  
 24. details of specific differences between spitfire models  
 25. details of what differentiated the Spitfire from other alternatives.



## Reading Passage 3

**Nature's Most Violent Wind**

- A. Tornadoes have been observed in every continent on the planet with the exception of Antarctica. Hurricanes differ from tornadoes, in that the former develop in warm, tropical oceans whereas tornadoes develop on land and are more aggressive and potentially destructive. The majority of tornadoes are initiated by thunderstorms. Tornadoes are relatively common occurrences at differing magnitudes throughout the world. The geographical features of the U.S.A. lend themselves to high incidence of tornado activity. In that country the highest proportion of tornadoes occur in the southern states in spring from March to May and in the northern states from late spring extending into summer. Generally tornadoes travel from southwest to northeast, though neither time of year nor direction they will take is completely predictable.
- B. Several factors cause the U.S.A. to experience a high incidence of tornado formation. While the continent reaches from arctic areas in the north to a tropical climate in the south there is no barrier protection from significant mountain ranges in the east or west; however, the Rocky Mountains in the middle latitudes of the country obstruct atmospheric flow and moisture. In addition, drier air from the southwest deserts and low level moisture from the Gulf of Mexico meet in the area, many collisions of warm and cool air occur and optimum conditions for tornado formation are created. Tornadoes in this central part of the U.S.A. are so prolific that the area has been named Tornado Alley, the site of the highest number of powerful tornadoes in the country and throughout the world. In the USA alone, in an average year 1200 tornadoes occur causing 70 fatalities and 1500 injuries and in addition extensive damage to property and natural vegetation.
- C. Connected between a cloud base above (usually cumulonimbus) and the earth below, a tornado is a rapidly rotating column of air; they can be as much as 20 kilometres in height. The majority are less than 75 metres in diameter reaching wind speeds of less than 177kms per hour and travel less than 10 kilometres before dissipating; however, some of the larger and rarer of this type of weather phenomenon may reach wind speeds of more than 480kms/hour traveling more than 100 kilometers before cessation. The inside of a tornado is made up of descending air and this is surrounded by a spiraling upward current which has the ability to carry with it and destroy even substantial obstacles such as trees, cars and houses in its path. Scientific research and eyewitness accounts indicate that most tornadoes also possess a calm centre in their core, surrounded by the layers of the downward and upward currents of air; this core has been likened to the peaceful central 'eye' at the centre of a tropical cyclone or hurricane.
- D. A tornado itself is not necessarily visible; though the intense low pressure it causes often results in condensation of water vapour which forms into a noticeable condensation funnel. Colours of tornadoes are also dictated by the environment in which they form. The force of the swirling air causes them to pick up dirt as they travel across the landscape; those with minimal debris remaining grey or white turning darker blue the more they collect, while others in areas such as the Great Plains in the USA turn red in colour due to the red soil they collect and carry with them. Background lighting in which a tornado presents itself also affects the naked eye's ability to identify its form as it appears on the horizon. When viewing a tornado with the sun behind it, it will appear to be dark in colour; however, when viewed without the sun in the background, the same tornado appears to be grey or white. On the rare occasions that tornadoes occur after dark, they pose an increased level of danger as darkness can make them invisible and only radar warnings or possibly sound can warn those in their path that a tornado is on its way.
- E. Tornadoes are classified into three levels of intensity; these being weak, strong and violent. 88% of tornadoes occurring in the USA are classified into the first category making them the most common; they account for less than 5% of fatalities resulting from tornado activity, generally reach wind speeds of less than 177kms/hour and have a duration of between 1 and

10 minutes before cessation. In contrast, 'violent' tornados exceed 330 kilometres per hour, can continue for over an hour and while they account for only 1% of incidence of tornados they result in approximately 70% of resultant deaths. The greatest devastation to date, inflicted on the USA by a violent tornado was on March 18th, 1925. The tornado was the longest, fastest and widest tornado known to have formed in North America and resulted in 695 deaths, an additional 2279 being injured. Now known as the Tri-state Tornado, it travelled over 350 kilometres affecting 13 counties in the three different states of Missouri, Illinois and Indiana. Around 11% of tornados are classified as 'strong' tornados. These tornados account for slightly more than 25% of tornado-related fatal accidents and reach mid-range speeds of between 177 and 330 kilometres per hour with an average duration of around 20 minutes.

- F. Today in the USA, early warning systems, which cannot necessarily protect property in the path of a tornado, can allow people time to leave the area and therefore significantly reduce death tolls. However in countries such as Bangladesh, fatalities caused by tornado impact remain extremely high. The rural, central region of the country also experiences a high frequency of strong tornados and the danger is exacerbated due to its densely populated areas, lack of warning systems and vulnerability of building structures. Between 1967 and 1996 the Bangladesh Observer and Pakistan Observer reported 5,373 tornado related deaths: an average of 179.1 per year. The Manikganj Tornado which occurred in 1989 is thought to have caused as many as 1300 deaths and is known as the deadliest tornado to have occurred anywhere in the world. Many projects delivered by organizations such as the Asian Disaster Reduction Centre (ADRC) have been established with the aim of minimising devastation and death rates caused by tornados in such areas.

#### Questions 26-30

*Choose the correct letter, A, B, C or D. Write your answer in boxes 26-30 on your answer sheet.*

26. Hurricanes are described as
- more hostile than tornados and occurring in the sea
  - occurring on land and less harmful than tornados
  - less damaging than tornados and occurring in marine environments
  - only occurring in certain oceans with a fiercer effect than a tornado
27. Tornados in the USA
- occur only in spring and summer
  - continually travel from southwest to northeast
  - are less prevalent in winter
  - are experienced exclusively by the southern and northern states
28. Tornados are common in the USA because
- the Rocky Mountains inhibit cold air from the north and warm air from the south making contact
  - because warm, humid air which builds up meets cooler air without interference
  - of the high incidence of thunderstorms which are experienced in central USA
  - warm air from the tropics allows optimum conditions to develop
29. Tornados may be very light in colour if
- the observer stands with their back to the sun
  - they occur at night
  - they occur in the Great Plains of the USA
  - they pick up substantial dirt on their journey
30. Tornados in Bangladesh
- are of greater intensity than in USA
  - can now be effectively predicted
  - occur mainly in urban areas
  - cause extensive damage due to sociological factors

## Questions 31-35

Label the diagram below.

Choose **NO MORE THAN TWO WORDS** from the passage for each answer.

Write your answers in boxes 31-35 on your answer sheet.

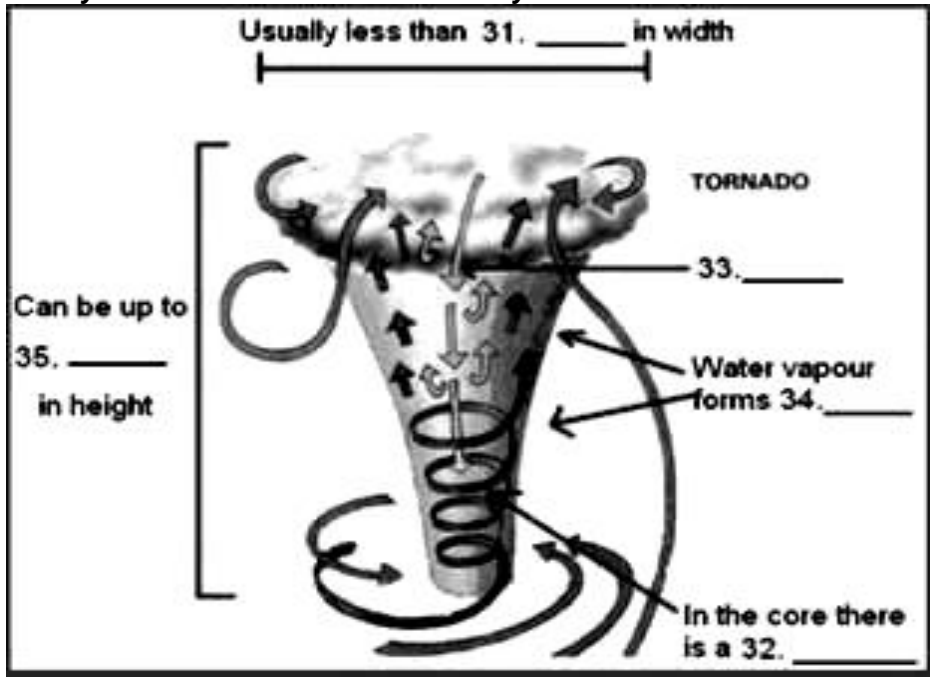

## Questions 36-40

Complete the table below. Choose **NO MORE THAN THREE WORDS OR A NUMBER** from the passage for each answer. Write your answers in boxes 36-40 on your answer sheet

Classification	Weak	Strong	Violent
Incidence	make up 36. _____ of tornados in the USA	make up about 37. _____ of tornados in the USA	make up the smallest minority of tornados in the USA
Wind speed	less than 177kms/hr	between 177 and 330 kms/hr	more than 330 kms/hr
Lifespan	1-10 minutes	20 minutes	38. can last for _____
Impact	cause less than 5% of tornado related deaths	cause just over 39. _____ of tornado related deaths	The most violent example in the USA was the 40. _____.



Reading 2Dyslexia

Paragraph 1 People who left school unable to read were often dismissed as being lazy. Some probably were but many were simply unable to learn because they were dyslexic. Four key findings now suggest that dyslexia is an organic problem and not a motivational one. Firstly the brain anatomy of dyslexics differs slightly from those of non dyslexics. Secondly their brain functions as measured by electrical activity are dissimilar. Thirdly they have behavioral differences apart from an inability to read. Finally there is more and more evidence to suggest that their condition is linked to particular genes.

Paragraph 2 The anatomical differences between the brains of dyslexics and non- dyslexics were first noticed in 1979 by Albert Galaburda of Harvard Medical School. He found two sorts of microscopic flaws in the language centres of dyslexic's brains. These are called ectoplasts and microgyria.

Paragraph 3 The language centres form part of the cerebral cortex and are situated on the left side of the brain. The cortex consists of six layers of cells. An ectopia is a collection of nerve cells that push up from the lower layers of the cortex into the outer ones, where they are not normally found. A microgyrus is a small fold in the cortex which results in a reduction in the normal number of layers from six to four.

Paragraph 4 The formation of microgyria causes confusion in the neural connections between the language centres and other parts of the brain. Microgyria have been induced in rat embryos and as adults these rats are found to have a reduced ability in distinguishing between two sounds played in quick succession. This inability to distinguish between two sounds in quick succession is also a symptom of dyslexia in people.

Paragraph 5 Dyslexia not only affects language centres but also causes brain abnormalities in visual pathways as well. One such abnormality is the reduction in the cell size in the layers of the lateral geniculate nucleus. This is where the nerve tracts which transmit information from the eyes to the visual cortex at the back of the brain are found. This is significant as dyslexia is essentially an inability to deal with linguistic information in visual form.

Paragraph 6 This parallel failure of visual and auditory systems is seen elsewhere in the brain. Guinevere Eden and Thomas Zeffiro, who work at Georgetown University in Washington D. C. have found an example of it using a brain scanning technique called functional magnetic resonance imaging.(MRI)

Paragraph 7 A fundamental characteristic of dyslexia is difficulty in processing written phenomes. Phenomes are the units of sound which make up a language. By giving dyslexic people tasks such as removing phenomes from the beginning of words, while at the same time monitoring brain activity with their scanner, Dr Eden and Dr Zeffiro were able to stimulate both the visual and auditory pathways simultaneously. Their findings demonstrated that dyslexics showed low activity in a part of the brain called Brodmann's area 37, another part of the brain where visual and auditory information are handled in close proximity.

Paragraph 8 Dr Eden and Dr Zeffiro have also compared the brain activity of dyslexic and non-dyslexic readers who were given a task not related to reading. Another symptom of dyslexia is difficulty in detecting visual motion. On this basis Dr Eden and Dr Zeffiro devised a task whereby people were asked to look at dots on a screen and identify which of them was moving and in which direction. While monitoring brain activity with the scanner, it was found that dyslexics performing this task showed significantly less brain activity in Brodmann's area 37 than non dyslexics. As this task did not require reading skills it could be used to test children for incipient dyslexia before they reach the reading age; then they could be given special tuition.

Paragraph 9 To broaden their investigation, Dr Eden and Dr Zeffiro teamed up with Frank Wood and his colleagues at the Wake Forest University School of Medicine in North Carolina, an institution specializing in dyslexia. Dr Eden and Dr Zeffiro borrowed some of its patients and monitored them in the fMRI machine at Georgetown University. This was done both before and after the individuals had participated in an intensive programme designed to improve their reading. Non- dyslexics were also scanned and used as controls in the investigation.

Paragraph 10 The results were significant. After the programme, the participants showed enhanced brain activity while reading. However this activity was not on the left side of the brain

but in areas on the right side, corresponding exactly to language centres in the opposite hemisphere. The reading programme had stimulated the brains of the participants to recruit batches of nerve cells in a place not normally associated with language processing.

**Paragraph 11** The primary cause for these problems is another of Dr Wood's interests. The abnormal brain tissue in dyslexia is developed by the fifth month of gestation, which indicates that the cause of the disorder must act before that time. This suggests that it may be genetic. Many people argue about the relative contributions of genes and the environment to human behaviour and human disease. Dyslexia is both behavioural and, to a certain degree, it is a disease. It appears to have a biological origin and genetic roots. Yet looking at it from a different angle its cause is almost purely environmental. People living in illiterate societies are hardly troubled by its other symptoms. It was the invention of writing that brought the difficulty to light, not the mutation of genes. Nature or environment? You will have to decide between the two.

#### **Questions 1-6**

Do the following statements agree with the views of the writer in reading passage

TRUE if the statement agrees with the writer  
 FALSE if the statement contradicts the writer  
 NOT GIVEN if there is no information about this

1. Dyslexia is probably caused by motivational problems.
2. Dyslexia affects language as well as visual and audio processes.
3. In modern society dyslexia is essentially the inability to distinguish between visual forms.
4. It has been demonstrated that special reading programmes can teach dyslexic people to read as well as non- dyslexic ones.
5. The cause of dyslexia is partly genetic and partly environmental.
6. The writer of the article believes that dyslexia can most effectively be cured in illiterate societies.

#### **Questions 7-11**

Match the items from the reading passage to the definitions. Choose the correct letters A B C D

7. Ectopia
  - A. a reduction in the number of layers in part of the cortex of the brain.
  - B. a collection of nerve cells in a part of the cortex of the brain where they are not normally found.
  - C. a formation of six layers in the cortex of the brain, where normally there are four.
  - D. an inability to deal with linguistic information in visual form.
8. Microgyria
  - A. a symptom of dyslexia.
  - B. abnormal pathways of visual information in the brain.
  - C. an abnormal formation of layers in the cortex of the brain.
  - D. confusion resulting in inability to distinguish sounds in quick succession.
9. Phenomes
  - A. sounds made in quick succession.
  - B. part of language that dyslexics are unable to identify.
  - C. brain activity that can be monitored with special scanning techniques.
  - D. the units of sound which make up a language.
10. fMRI
  - A. a scientific equipment for assessing reading skills.
  - B. a technique for scanning activity of the brain.
  - C. a technique for stimulating visual and auditory pathways in the brain.
  - D. a machine to stimulate visual motion.
11. Brodmann's area 37
  - A. a less active part of the brain.
  - B. an abnormal formation in the brain of dyslexics.
  - C. where all visual information is handled in the brain.
  - D. part of the brain where visual and auditory information are handled.

#### **Questions 12-14**

Complete the sentences below with words taken from the reading passage. Use *no more than three words* for each answer

12. In the language centres of dyslexics brains, Dr Albert Galaburda discovered two sorts of -----
13. One abnormality in the dyslexics brains is the reduction in the cell size in the layers of the ----
14. Dyslexia is behavioural problem and also a -----

## READING PASSAGE 2

The Oscars

Paragraph 1 Once every year, the red carpet is rolled out and the stars begin to arrive in their limousines, dressed in their finest clothes, decked with jewels borrowed from some of the most exclusive shops in town and worth hundreds and thousands of dollars. It's the annual awards ceremony of the Academy of Motion Pictures Arts and Scientists, more commonly known as "the Oscars". For 75 years now, Hollywood has acknowledged the best actors, actresses, directors and writers with these awards, as well as others working behind the scenes in these movies.

Paragraph 2 The first Academy Awards were presented in 1927, although there was no ceremony that year. The first awards ceremony took place in 1929, a ceremony that differed in many ways from the ones we see today. In early ceremonies, a banquet was held for all participants and tickets cost only \$10. There were only 12 categories for prizes, today there are over 35. In those early years few movies had soundtracks – the movies were just becoming the talkies. But perhaps the biggest difference between the first ceremony and the ceremonies of today is that the winners of the awards were announced in advance of the ceremony – there was no element of surprise at all. It was not until 1941 that the "sealed envelope" was introduced, with all the drama and suspense that it entails. Today, the phrase "the envelope please" has become symbolic of all the tension and spectacle of the Oscars.

Paragraph 3 Today, over 70 million people view the Oscars ceremony each year, making it one of the most viewed programmes on TV. The ceremony appeared on television for the first time in 1953 and 1966 was the first time it was seen in colour. An enormous amount of work goes into the preparation of this, Hollywood's most important event, and perhaps for this reason, the ceremony has never been cancelled – though it has been postponed three times. Once the Oscars were postponed for floods (1938), and twice they've been postponed due to assassinations or attempted assassinations (1968,1981)

Paragraph 4 So, who have the big winners been? The most famous "best picture" is probably *Ben Hur*, which won 11 Academy Awards in 1959. The only other picture to win this many Oscars was *Titanic* in 2000. The two films have something else in common: they were both "big budget" movies, considered outrageously extravagant by many commentators. In fact the expression "bigger than Ben Hur" has passed into everyday English, to describe something huge, with no expense spared. *Titanic* was made with a record budget of US\$200 million, though it still made a handsome profit at the box office. Another big winner was the film *Gone with the Wind*, which won 8 awards in 1939. This was one of the longest movies (3 ½ hours) to win, and is still considered a film classic.

Paragraph 5 The winner of the Best Actress Award for *Gone with the Wind* was Vivien Leigh, a newcomer to the screen. She also won the Best Actress Award in 1951 for another film – *A Streetcar Named Desire*, the only other film for which she was nominated. Each year five actors and five actresses are nominated for the Best Actor Award and the Best Actress Awards and this in itself is a great honour. The actress to receive the most nominations is Meryl Streep, who has been nominated for 13 awards – and won two.. Katherine Hepburn however is the actress to have won the most awards – she won four Best Actress awards in her lifetime.

**Paragraph 6** Jack Nicholson is the only actor to win three Best Actor Awards, though Tom Hanks, Dustin Hoffman and Robert De Niro have all won two. Of these four actors, all but De Niro seem to bear out the theory that an actor's chance of winning a Best Actor, or Best Supporting Actor award, is greater if he is portraying a physically or mentally handicapped person. And if the character dies during the movie, this seems to help as well.

**Paragraph 7** In fact, there are many factors that can influence the awarding of prizes for actors and actresses, factors that may have little to do with their performance in a particular film. Sometimes awards are given to an actor or actress for a film that is not particularly outstanding, in order to honour a lifetime's work in the movie industry. This is considered the case, for example, for Paul Newman's win for his role in *The Colour of Money* (1986). And on other occasions, an award may be given in an attempt to "rectify past injustices" when it is felt that an actor or actress should have won an award for a previous movie. For example, a 76 year old Henry Fonda won an award for his performance in 1981's *On Golden Pond*, which many felt he had deserved years earlier for his role in *The Grapes of Wrath* (1940). Another factor which may influence the choice of the Academy is "the sympathy vote", such as Elizabeth Taylor's winning of the Best Actress award in 1960 for *Butterfield 8* – just after an almost fatal case of pneumonia.

**Paragraph 8** Whatever the reason for awarding those elusive gold figures, their power in enhancing career opportunities in the business is unquestionable, as is the continued spell they hold over the public.

**Questions 15-21**

Match the actor or actress in the left column with the reason they are mentioned in the text (A-F)

**Actor or Actress**

15. Elizabeth Taylor
16. Meryl Streep
17. Henry Fonda
18. Paul Newman
19. Jack Nicholson
20. Katherine Hepburn
21. Vivien Leigh

- A. has won the maximum awards in the Best Actor/Best Actress category
- B. received the award due to sympathy vote
- C. received an award for recognition of past work
- D. received an award to make up for being overlooked in the past.
- E. Has received the greatest number of nominations as Best Actor/Actress
- F. None of these reasons

**Questions 22-26**

Do the following statements agree with the views of the writer in reading passage 2? Write

- YES if the statement agrees with the writer  
 NO if the statement contradicts the writer  
 NOT GIVEN if it is impossible to say what the writer thinks about this

22. Robert De Niro did not play a handicapped person in his award winning films.
23. Tom Cruise is one actor who, despite many outstanding performances, has never received a Best Actor award.
24. The Oscars have never been cancelled.
25. The Oscar ceremony today includes a dinner for all participants.
26. More money was spent on Titanic than any other movie.

Reading Passage 3Electric Dreams

*The days of the internal-combustion are numbered, and the fuel cell represents the future of automotive transport, says PETER BREWER.*

- A. Some of the world's greatest inventions have been discovered by accident. One such accident led to the discovery of the fuel cell and another led to its commercialisation. And in around 30 years, when most of the energy analysts have predicted the oil wells will run dry, motorists will be thankful for both these strange twists of fate. Why? Simply because without the fuel cell to replace the combustion engine, private motoring as we all know it would be restricted to only those who could afford the high price.
- B. The exact date of the discovery of the fuel cell is not known, but historians agree it most likely occurred around 1938 in the laboratories of British physicist Sir William Grove, who one day disconnected a simple electrolytic cell (in which hydrogen and oxygen are produced when water contacts an electric current running through a platinum wire) and reversed the flow of current. As author records in his book *Powering the Future*, Grove realized that just as he could use electricity to split water into hydrogen and oxygen it should be possible to generate electricity by combining these two gases.
- C. The principle behind the fuel cell is simple. Hydrogen and oxygen, two of the most common elements in the world, are a very explosive combination. But separate them with a sophisticated platinum coated barrier and an electro chemical reaction takes place, where positively charged hydrogen ions react with oxygen and leave the hydrogen electrons behind. It is this reaction, the excess electrons on one side of the barrier and the deficit of electrons on the other that creates electrical energy.
- D. The early development of the fuel cell was fraught with problems and high cost. But by 1954 US giant General Electric had produced a prototype that proved sufficiently effective to interest NASA. The Gemini space programme proved the viability of the fuel cell to provide electrical power. The spacecraft used six stacks of cells with three cells in each stack. The electrical power output from each stack was quite modest – just one kilowatt and as a by-product, produced half a litre of water for each kilowatt hour of operation. But the Gemini Cells were very unstable and required constant monitoring.
- E. At this time if anyone had suggested to Canadian Scientist Geoffrey Ballard that he would become a world leader in fuel cell technology, he would have laughed. Ballard's scientific background was actually geophysics, but during the oil-crisis of 1973, the US government asked the Canadian to explore alternative forms of energy. Ballard threw himself into the project enthusiastically but soon became disillusioned by the politics of the programme. Energy systems take a long time to develop, Ballard said. The short-term vision of politicians, who voted to fund such projects in the desire for quick results to bolster their re-election chances, were frustrating for the scientists. However, since the US government lacked the vision for the job, he decided to tackle it himself.
- F. The big breakthrough on Ballard's fuel cell came by accident in the search for cheaper materials. Up until late 1986, Ballard's team had worked with only one type of fuel cell membrane manufactured by DuPont, but Dow Chemical had also developed a similar membrane, which had not been released for sale. Ballard's team tracked down an experimental sample of the Dow material, put it into a fuel cell and set up a standard test. Within a few minutes the fuel cell was generating so much electricity on the test bench that it had melted through the power-output cable.
- G. Ballard immediately knew he had a saleable product. The problem was: Should he aim his fuel cell at small markets like military field generators, wheelchairs and golf carts, or try to sell it as a full blown alternative to the combustion engine? "It was so needed and the world was ready for it," Ballard said. "Los Angeles is dying; Vancouver is going to be eaten alive by its own pollution very shortly. It seemed like a time to go for broke." Ballard Power Systems first built a small bus to demonstrate the technology, and then an even bigger bus.

- H. As a result a number of multinational motor manufacturers, such as General Motors, Mitsubishi and Daimler-Benz all tested Ballard's cells. Finally, Daimler formed an alliance with Ballard that has yielded some impressive prototypes, including a fully driveable fuel cell-powered A-class Mercedes-Benz compact car, known as Necar 4. Daimler Chrysler, as the merged Daimler-Benz and Chrysler Corporation is now known, says the fuel cell represents the future of automotive transport. "The significance of this technological advancement ( the fuel cell) is comparable to the impact the microchip had on computer technology when it replaced the transistor," said Dr Ferdinand Panik, the head of Daimler Chrysler's fuel cell development team.

#### Questions 27-34

There are 8 paragraphs numbered A-H in Reading Passage 3. From the list below numbered i- x, choose a suitable heading for the paragraphs.

There are more headings than paragraphs, so you will not use all the headings.

- |       |   |
|-------|---|
| i.    | A conflict of interests                               |
| ii.   | Science is sometimes a question of luck               |
| iii.  | Using the fuel cell in different ways                 |
| iv.   | How does it work?                                     |
| v.    | Deciding how to exploit the new product               |
| vi.   | Using the fuel cell to be the first in the space race |
| vii.  | A key stage in the development of fuel cell           |
| viii. | A first step on the road to a new source of energy    |
| ix.   | Applying the new technology on a global scale         |
| x.    | The first fuel cell is tested                         |

28. Paragraph B  
 29. Paragraph C  
 30. Paragraph D  
 31. Paragraph E  
 32. Paragraph F  
 33. Paragraph G  
 34. Paragraph H

#### Questions 35-37

Choose the most appropriate letter A B C or D

35. The fuel cell generates electricity because  
 A. hydrogen and oxygen can be used to create controlled explosions  
 B. of the reaction which occurs when hydrogen and oxygen are separated  
 C. hydrogen and oxygen are both gases  
 D. hydrogen and oxygen both contain electrons
36. The Gemini space programme demonstrated that  
 A. The fuel cell was too difficult to use in space programmes  
 B. The fuel cell can only work with pure oxygen  
 C. Generating a substantial amount of electricity requires many fuel cells  
 D. The fuel cell could be used successfully
37. The US government asked Ballard to carry out fuel cell research because  
 A. He was an expert in his field  
 B. supplies of oil were running out  
 C. They wanted to find new sources of energy  
 D. He offered to work completely independently.

#### Questions 38-40

Complete the sentences below by taking words from the passage. Use NO MORE THAN THREE WORDS

38. The key step in the development of fuel cell occurred completely -----  
 39. Ballard decided that the fuel cell could be used to reduce ----- in large cities.  
 40. In an attempt to produce a more ecological car, Ballard ----- with a major automobile corporation.



## ACADEMIC READING 3

**FINDING THE LOST FREEDOM**

1. The private car is assumed to have widened our horizons and increased our mobility. When we consider our children's mobility, they can be driven to more places (and more distant places) than they could visit without access to a motor vehicle. However, allowing our cities to be dominated by cars has progressively eroded children's independent mobility. Children have lost much of their freedom to explore their own neighbourhood or city without adult supervision. In recent surveys, when parents in some cities were asked about their own childhood experiences, the majority remembered having more, or far more, opportunities for going out on their own, compared with their own children today. They had more freedom to explore their own environment.
2. Children's independent access to their local streets may be important for their own personal, mental and psychological development. Allowing them to get to know their own neighbourhood and community gives them a 'sense of place'. This depends on 'active exploration', which is not provided for when children are passengers in cars. (Such children may see more, but they learn less.) Not only is it important that children be able to get to local play areas by themselves, but walking and cycling journeys to school and to other destinations provide genuine play activities in themselves.
3. There are very significant time and money costs for parents associated with transporting their children to school, sport and to other locations. Research in the United Kingdom estimated that this cost, in 1990, was between 10 billion and 20 billion pounds.
4. The reduction in children's freedom may also contribute to a weakening of the sense of local community. As fewer children and adults use the streets as pedestrians, these streets become less sociable places. There is less opportunity for children and adults to have the spontaneous of community. This in itself may exacerbate fears associated with assault and molestation of children, because there are fewer adults available who know their neighbours' children, and who can look out for their safety.
5. The extra traffic involved in transporting children results in increased traffic congestion, pollution and accident risk. As our roads become more dangerous, more parents drive their children to more places, thus contributing to increased levels of danger for the remaining pedestrians. Anyone who has experienced either the reduced volume of traffic in peak hour during school holidays, or the traffic jams near schools at the end of a school day, will not need convincing about these points. Thus, there are also important environmental implications of children's loss of freedom.
6. As individuals, parents strive to provide the best upbringing they can for their children. However, in doing so, (e.g. by driving their children to sport, school or recreation) parents may be contributing to a more dangerous environment for children generally. The idea that 'streets are for cars and back yards and playgrounds are for children' is a strongly held belief, and parents have little choice as individuals but to keep their children off the streets if they want to protect their safety.
7. In many parts of Dutch cities, and some traffic calmed precincts in Germany, residential streets are now places where cars must give way to pedestrians. In these areas, residents are accepting the view that the function of streets is not solely to provide mobility for cars. Streets may also be for social interaction, walking, cycling and playing. One of the most important aspects of these European cities, in terms of giving cities back to children, has been a range of 'traffic calming' initiatives, aimed at reducing the volume and speed of traffic. These initiatives have had complex interactive effects, leading to a sense that children have been able to 'recapture' their local neighbourhood, and more importantly, that they have been able to do this in safety. Recent research has demonstrated that children in many German cities have significantly higher levels of freedom to travel to places in their own neighbourhood or city than children in other cities in the world.
8. Modifying cities in order to enhance children's freedom will not only benefit children. Such cities will become more environmentally sustainable, as well as more sociable and more livable for all

city residents. Perhaps it will be our concern for our children's welfare that convinces us that we need to challenge the dominance of the car in our cities.

**Questions 1-5**

Read statements 1-5 which relate to Paragraphs 1, 2, and 3 of the reading passage. Answer

- T if the statement is true,
- F if the statement is false, or
- NI if there is no information given in the passage

Example: The private car has made people more mobile. Answer: T

1. The private car has helped children have more opportunities to learn.
2. Children are more independent today than they used to be.
3. Walking and cycling to school allows children to learn more.
4. Children usually walk or cycle to school.
5. Parents save time and money by driving children to school.

**Questions 6-9**

In Paragraphs 4 and 5, there are FOUR problems stated. These problems, numbered as questions 6-9, are listed below. Each of these problems has a cause, listed A-G. Find the correct cause for each of the problems and write the corresponding letter A-G, in the spaces numbered 6-9 on the answer sheet. One has been done for you as an example.

There are more causes than problems so you will not use all of them and you may use any cause more than once.

Problems	Causes
Example: low sense of community well being	Answer F
6. Streets become less sociable	A. Few adults know local children
7. Fewer chances of meeting friends	B. Fewer people use the streets
8. Fears of danger for children	C. Increased pollution
9. Higher accident risk	D. Streets are less friendly
	E. Less traffic in school holidays
	F. Reduced freedom for children
	G. More children driven to school

**Questions 10-14**

Questions 10-14 are statement beginnings which represent information given in Paragraphs 6, 7 and 8. In the box below, there are some statement endings numbered i-x. Choose the correct ending for each statement.

There are more statement endings than you will need.

Example: By driving their children to school, parents help create ... Answer: i

10. Children should play ...
11. In some German towns, pedestrians have right of way ...
12. Streets should also be used for ...
13. Reducing the amount of traffic and the speed is ...
14. All people who live in the city will benefit if cities are ...

List of statement endings

- i. ... a dangerous environment.
- ii. ... modified.
- iii. ... on residential streets.
- iv. ... modifying cities.
- v. ... neighbourhoods.
- vi. ... socialising.
- vii. ... in backyards.
- viii. ... for cars.
- ix. ... traffic calming.
- x. ... residential

## READING PASSAGE 2

RISING SEA**Paragraph 1. INCREASED TEMPERATURES**

The average air temperature at the surface of the earth has risen this century, as has the temperature of ocean surface waters. Because water expands as it heats, a warmer ocean means higher sea levels. We cannot say definitely that the temperature rises are due to the greenhouse effect; the heating may be part of a 'natural' variability over a long time-scale that we have not yet recognized in our short 100 years of recording. However, assuming the build up of greenhouse gases is responsible, and that the warming will continue, scientists – and inhabitants of low-lying coastal areas – would like to know the extent of future sea level rises.

**Paragraph 2.**

Calculating this is not easy. Models used for the purpose have treated the ocean as passive, stationary and one-dimensional. Scientists have assumed that heat simply diffused into the sea from the atmosphere. Using basic physical laws, they then predict how much a known volume of water would expand for a given increase in temperature. But the oceans are not one-dimensional, and recent work by oceanographers, using a new model which takes into account a number of subtle facets of the sea – including vast and complex ocean currents – suggests that the rise in sea level may be less than some earlier estimates had predicted.

**Paragraph 3.**

An international forum on climate change, in 1986, produced figures for likely sea-level rises of 20 cms and 1.4 m, corresponding to atmospheric temperature increases of 1.5 and 4.5C respectively. Some scientists estimate that the ocean warming resulting from those temperature increases by the year 2050 would raise the sea level by between 10 cms and 40 cms. This model only takes into account the temperature effect on the oceans; it does not consider changes in sea level brought about by the melting of ice sheets and glaciers, and changes in groundwater storage. When we add on estimates of these, we arrive at figures for total sea-level rises of 15 cm and 70 cm respectively.

**Paragraph 4.**

It's not easy trying to model accurately the enormous complexities of the ever-changing oceans, with their great volume, massive currents and sensitively to the influence of land masses and the atmosphere. For example, consider how heat enters the ocean. Does it just 'diffuse' from the warmer air vertically into the water, and heat only the surface layer of the sea? (Warm water is less dense than cold, so it would not spread downwards). Conventional models of sea-level rise have considered that this the only method, but measurements have shown that the rate of heat transfer into the ocean by vertical diffusion is far lower in practice than the figures that many modelers have adopted.

**Paragraph 5.**

Much of the early work, for simplicity, ignored the fact that water in the oceans moves in three dimensions. By movement, of course, scientists don't mean waves, which are too small individually to consider, but rather movement of vast volumes of water in huge currents. To understand the importance of this, we now need to consider another process – advection. Imagine smoke rising from a chimney. On a still day it will slowly spread out in all directions by means of diffusion. With a strong directional wind, however, it will all shift downwind, this process is advection – the transport of properties (notably heat and salinity in the ocean) by the movement of bodies of air or water, rather than by conduction or diffusion.

**Paragraph 6.**

Massive ocean currents called gyres do the moving. These currents have far more capacity to store heat than does the atmosphere. Indeed, just the top 3 m of the ocean contains more heat than the whole of the atmosphere. The origin of gyres lies in the fact that more heat from the Sun reaches the Equator than the Poles, and naturally heat tends to move from the former to the latter. Warm air rises at the Equator, and draws more air beneath it in the form of winds (the "Trade Winds") that, together with other air movements, provide the main force driving the ocean currents.

**Paragraph 7.**

Water itself is heated at the Equator and moves poleward, twisted by the Earth's rotation and affected by the positions of the continents. The resultant broadly circular movements between about 10 and 40 North and South are clockwise in the Southern Hemisphere. They flow towards the east at mid latitudes in the equatorial region. They then flow towards the Poles, along the eastern sides of continents, as warm currents. When two different masses of water meet, one will move beneath the other, depending on their relative densities in the subduction process. The densities are determined by temperature and salinity. the convergence of water of different densities from the Equator and the Poles deep in the oceans causes continuous subduction. This means that water moves vertically as well as horizontally. Cold water from the Poles travels as depth – it is denser than warm water – until it emerges at the surface in another part of the world in the form of a cold current.

**Paragraph 8. HOW THE GREEN HOUSE EFFECT WILL CHANGE OCEAN TEMPERATURES**

Ocean currents, in three dimensions, form a giant 'conveyor belt', distributing heat from the thin surface layer into the interior of the oceans and around the globe. Water may take decades to circulate in these 3-D gyres in the top kilometer of the ocean, and centuries in the deep water. With the increased atmospheric temperatures due to the greenhouse effect, the oceans conveyor belt will carry more heat into the interior. This subduction moves heat around far more effectively than simple diffusion. Because warm water expands more than cold when it is heated, scientists had presumed that the sea level would rise unevenly around the globe. It is now believed that these inequalities cannot persist, as winds will act to continuously spread out the water expansion. Of course, of global warming changes the strength and distribution of the winds, then this 'evening-out' process may not occur, and the sea level could rise more in some areas than others.

**Questions 15-20**

There are 8 paragraphs numbered 1-8 in Reading Passage 2. The first paragraph and the last paragraph have been given headings. From the list below numbered A-I, choose a suitable heading for the remaining 6 paragraphs. There are more headings than paragraphs, so you will not use all the headings.

- 15. Paragraph 2
- 16. Paragraph 3
- 17. Paragraph 4
- 18. Paragraph 5
- 19. Paragraph 6
- 20. Paragraph 7

**List of headings**

- A THE GYRE PRINCIPLE
- B THE GREENHOUSE EFFECT
- C HOW OCEAN WATERS MOVE
- D STATISTICAL EVIDENCE
- E THE ADVECTION PRINCIPLE
- F DIFFUSION VERSUS ADVECTION
- G FIGURING THE SEA LEVEL CHANGES

**Questions 21 and 22****Circle the correct answer**

21. Scientists do not know for sure why the air and surface of ocean temperatures are rising because:

- A. there is too much variability
- B. there is not enough variability
- C. they have not been recording these temperatures for enough time
- D. the changes have only been noticed for 100 years

22. New research leads scientists to believe that:

- A. the oceans are less complex
- B. he oceans are more complex
- C. the oceans will rise more than expected
- D. the oceans will rise less than expected

**Question 23**

Look at the following list of factors A-F and select THREE which are mentioned in the reading passage which may contribute to the rising ocean levels. Write the THREE corresponding letters A-F, in the space numbered 23 on the answer sheet.

**List of factors**

A thermal expansion

B melting ice

C increased air temperature

D higher rainfall

E changes in the water table

F increased ocean movement

**Questions 24-28**

Read each of the following statements, 24-28. According to the information in the reading passage, if the statement is true, write T, if it is false, write F and if there is no information about the statement in the reading passage, write N1. Write your answers in the spaces numbered 24-28 on the answer sheet.

24. The surface layer of the oceans is warmed by the atmosphere.

25. Advection of water changes heat and salt levels.

26. A gyre holds less heat than there is in the atmosphere.

27. The process of subduction depends on the water density.

28. The sea level is expected to rise evenly over the Earth's surface

**READING PASSAGE 3****NEW RULES EQR THE PAPER GAME**

1. Computerised data storage and electronic mail were to have heralded the paperless office. But, contrary to expectations, paper consumption throughout the world shows no sign of abating. In fact, consumption, especially of printing and writing papers, continues to increase. World demand for paper and board is now expected to grow faster than the general economic growth in the next 15 years. Strong demand will be underpinned by the growing industrialization of South-East Asia, the re-emergence of paper packaging, greater use of facsimile machines and photocopiers, and the popularity of direct-mail advertising. It is possible that by 2007, world paper and board demand will reach 455 million tonnes, compared with 241 million tonnes in 1991.
2. The pulp and paper industry has not been badly affected by the electronic technologies that promised a paperless society. But what has radically altered the industry's structure is pressure from another front—a more environmentally conscious society driving an irreversible move towards cleaner industrial production. The environmental consequences of antiquated pulp mill practices and technologies had marked this industry as one in need of reform. Graphic descriptions of deformed fish and thinning populations, particularly in the Baltic Sea where old pulp mills had discharged untreated effluents for 100 years, have disturbed the international community.
3. Until the 1950s, it was common for pulp mills and other industries to discharge untreated effluent into rivers and seas. The environmental effects were at the time either not understood, or regarded as an acceptable cost of economic prosperity in an increasingly import-oriented world economy. But greater environmental awareness has spurred a fundamental change in attitude in the community, in government and in industry itself.
4. Since the early 1980s, most of the world-scale pulp mills in Scandinavia and North America have modernised their operations, outlaying substantial amounts to improve production methods. Changes in mill design and processes have been aimed at minimising the environmental effects of effluent discharge while at the same time producing pulp with the whiteness and strength demanded by the international market. The environmental impetus is taking this industry even further, with the focus now on developing processes that may even eliminate waste-water discharges. But the ghost of the old mills continues to haunt the industry today. In Europe,

companies face a flood of environment-related legislation. In Germany, companies are now being held responsible for the waste they create.

5. Pulp is the porridge-like mass of plant fibres from which paper is made. Paper makers choose the type of plant fibre and the processing methods, depending on what the end product will be used for: whether it is a sturdy packing box, a smooth sheet of writing paper or a fragile tissue. In wood, which is the source of about 90% of the world's paper production, fibres are bound together by lignin, which gives the unbleached pulp a brown colour. The pulping stage separates the wood into fibres so they are suitable for paper making. Pulping can be done by mechanical grinding, or by chemical treatment in which woodchips are 'cooked' with chemicals, or by a combination of both methods.
6. Kraft pulping is the most widely used chemical process for producing pulp with the strength required by the high-quality paper market. It is now usually carried out in a continuous process in a large vessel called a digester. Woodchips are fed from a pile into the top of the digester. In the digester, the chips are cooked in a solution called white liquor, nosed of caustic soda (sodium hydroxide) sodium sulphide. The chips are cooked at high temperatures of up to 170° C for up to three hours. The pulp is then washed and rate from the spent cooking liquor which has turned dark and is now appropriately ailed black liquor. An important feature of kraft pulping is a chemical recovery system which recycles about 95% of the cooking chemicals and produces more than enough energy to run the mill. In a series of steps involving a furnace and tanks, some of the black liquor is transformed into energy, while some is regenerated into the original white cooking liquor. The recovery system is an integral part of production in the pulp and paper industry. The pulp that comes out has little lignin left in the fibres. Bleaching removes the last remaining lignin and brightens the pulp. Most modern mills have modified their pulping processes to remove as much of the lignin as possible before the pulp moves to the bleaching stage.

**Questions 29-32** Below is a list of possible factors, A-G, which will influence the amount of paper being used in the future. From the list, choose FOUR factors which are mentioned in Paragraph 1 of the reading passage. Write your answers A-G, in the spaces numbered 29-32 on the answer sheet.

**List of factors**

- A more people read newspapers
- B increased use of paper bags
- C increased book production for education
- D wider use of sign post advertising
- E increased use of fax machines
- F wider use of leaflet advertising
- G greater use of duplicating machines

**Questions 33-35**

The following THREE statements are summaries of Paragraphs 2, 3 and 4 respectively. However, they are incomplete. Complete each of the statements using NO MORE THAN THREE WORDS FROM THE TEXT. Write your answers in the spaces numbered 33-35 on the answer sheet.

33. The international community has begun to demand ...
34. In the past, the environmental effects of pulp mill practices, were probably a price to pay for ...
35. Some paper mills have recently modernised their mill design in order to decrease...

**Questions 36-40**

Below is a list of possible steps in the kraft process of turning wood chips into paper. They are numbered 1-8. Only FIVE of the steps listed below are mentioned in the passage. The steps are not listed in the correct order. Decide which steps are mentioned and write them in the correct order.

1. the chips are cooked
2. the fibres are bound by lignin
3. the pulp is bleached
4. woodchips are put into a pile
5. the pulp is dried
6. the pulp is removed from the black liquor
7. the chips are put into the white liquor
8. the pulp is washed



**Academic Reading 4 COMPLETE READING TEST – OUP NET**

Reading Passage 1 has nine paragraphs A–I. Choose the most suitable headings for each paragraph from the list of headings given.

**List of headings**

- |       |                                       |
|-------|---------------------------------------|
| i.    | Island legends                        |
| ii.   | Resources for exchange                |
| iii.  | Competition for fishing rights        |
| iv.   | The low cost of equipment             |
| v.    | Agatti's favourable location          |
| vi.   | Rising income levels                  |
| vii.  | The social nature of reef occupations |
| viii. | Resources for islanders' own use      |
| ix.   | High levels of expertise              |
| x.    | Alternative sources of employment     |
| xi.   | Resources for earning money           |
| xii.  | Social rights and obligations         |

1. Paragraph A
2. Paragraph B
3. Paragraph C
4. Paragraph D
5. Paragraph E
6. Paragraph F
7. Paragraph G
8. Paragraph H
9. Paragraph I

**The coral reefs of Agatti Island**

- A. Agatti is one of the Lakshadweep Islands off the south-west coast of India. These islands are surrounded by lagoons and coral reefs which are in turn surrounded by the open ocean. Coral reefs, which are formed from the skeletons of minute sea creatures, give shelter to a variety of plants and animals, and therefore have the potential to provide a stream of diverse benefits to the inhabitants of Agatti Island.
- B. In the first place, the reefs provide food and other products for consumption by the islanders themselves. Foods include different types of fish, octopus and molluscs, and in the case of poorer families these constitute as much as 90% of the protein they consume. Reef resources are also used for medicinal purposes. For example, the money cowrie, a shell known locally as *Vallakavadi*, is commonly made into a paste and used as a home remedy to treat cysts in the eye.
- C. In addition, the reef contributes to income generation. According to a recent survey, 20% of the households on Agatti report lagoon fishing, or shingle, mollusc, octopus and cowrie collection as their main occupation (Hoon et al, 2002). For poor households, the direct contribution of the reef to their financial resources is significant: 12% of poor households are completely dependent on the reef for their household income, while 59% of poor households rely on the reef for 70% of their household income, and the remaining 29% for 50% of their household income.
- D. Bartering of reef resources also commonly takes place, both between islanders and between islands. For example, Agatti Island is known for its abundance of octopus, and this is often used to obtain products from nearby Androth Island. Locally, reef products may be given by islanders in return for favours, such as help in constructing a house or net mending, or for other products such as rice, coconuts or fish.
- E. The investment required to exploit the reefs is minimal. It involves simple, locally available tools and equipment, some of which can be used without a boat, such as the fishing practice known as *Kat moodsal*. This is carried out in the shallow eastern lagoon of Agatti by children and adults, close to shore at low tide, throughout the year. A small cast net, a leaf bag, and plastic slippers are all that are required, and the activity can yield 10–12 small fish (approximately 1 kg) for

household consumption. Cast nets are not expensive, and all the households in Agatti own at least one. Even the boats, which operate in the lagoon and near-shore reef, are constructed locally and have low running costs. They are either small, non-mechanical, traditional wooden rowing boats, known as *Thonis*, or rafts, known as *Tharappam*.

- F. During more than 400 years of occupation and survival, the Agatti islanders have developed an intimate knowledge of the reefs. They have knowledge of numerous different types of fish and where they can be found according to the tide or lunar cycle. They have also developed a local naming system or folk taxonomy, naming fish according to their shape. Sometimes the same species is given different names depending on its size and age. For example, a full grown Emperor fish is called *Metti* and a juvenile is called *Killokam*. The abundance of each species at different fishing grounds is also well known. Along with this knowledge of reef resources, the islanders have developed a wide range of skills and techniques for exploiting them. A multitude of different fishing techniques are still used by the islanders, each targeting different areas of the reef and particular species.
- G. The reef plays an important role in the social lives of the islanders too, being an integral part of traditions and rituals. Most of the island's folklore revolves around the reef and sea. There is hardly any tale or song which does not mention the traditional sailing crafts, known as *Odams*, the journeys of enterprising 'heroes', the adventures of sea fishing and encounters with sea creatures. Songs that women sing recollect women looking for returning *Odams*, and requesting the waves to be gentler and the breeze just right for the sails. There are stories of the benevolent sea ghost *baluvam*, whose coming to shore is considered a harbinger of prosperity for that year, bringing more coconuts, more fish and general well-being.
- H. The reef is regarded by the islanders as common property, and all the islanders are entitled to use the lagoon and reef resources. In the past, fishing groups would obtain permission from the *Amin* (island head person) and go fishing in the grounds allotted by him. On their return, the *Amin* would be given a share of the catch, normally one of the best or biggest fish. This practice no longer exists, but there is still a code of conduct or etiquette for exploiting the reef, and common respect for this is an effective way of avoiding conflict or disputes.
- I. Exploitation of such vast and diverse resources as the reefs and lagoon surrounding the island has encouraged collaborative efforts, mainly for purposes of safety, but also as a necessity in the operation of many fishing techniques. For example, an indigenous gear and operation known as *Bala fadal* involves 25–30 men. Reef gleaning for cowrie collection by groups of 6–10 women is also a common activity, and even today, although its economic significance is marginal, it continues as a recreational activity.

#### Questions 10-13

10. What proportion of poor households get all their income from reef products?
- 12%
  - 20%
  - 29%
  - 59%
11. *Kat moodsal* fishing
- is a seasonal activity.
  - is a commercial activity.
  - requires little investment.
  - requires use of a rowing boat.
12. Which characteristic of present-day islanders do the writers describe?
- physical strength
  - fishing expertise
  - courage
  - imagination
13. What do the writers say about the system for using the reef on Agatti?
- Fish catches are shared equally.
  - The reef owner issues permits.
  - There are frequent disputes.
  - There is open access.

## Passage 2

### Urban Planning in Singapore

British merchants established a trading post in Singapore in the early nineteenth century, and for more than a century trading interests dominated. However, in 1965 the newly independent island state was cut off from its hinterland, and so it set about pursuing a survival strategy. The good international communications it already enjoyed provided a useful base, but it was decided that if Singapore was to secure its economic future, it must develop its industry. To this end, new institutional structures were needed to facilitate, develop, and control foreign investment. One of the most important of these was the Economic Development Board (EDB), an arm of government that developed strategies for attracting investment. Thus from the outset, the Singaporean government was involved in city promotion.

Towards the end of the twentieth century, the government realised that, due to limits on both the size of the country's workforce and its land area, its labour-intensive industries were becoming increasingly uncompetitive. So an economic committee was established which concluded that Singapore should focus on developing as a service centre, and seek to attract company headquarters to serve South East Asia, and develop tourism, banking, and off shore activities. The land required for this service-sector orientation had been acquired in the early 1970s, when the government realised that it lacked the banking infrastructure for a modern economy. So a new banking and corporate district, known as the 'Golden Shoe', was planned, incorporating the historic commercial area. This district now houses all the major companies and various government financial agencies.

Singapore's current economic strategy is closely linked to land use and development planning. Although it is already a major city, the current development plan seeks to ensure Singapore's continued economic growth through restructuring, to ensure that the facilities needed by future business are planned now. These include transport and telecommunication infrastructure, land, and environmental quality. A major concern is to avoid congestion in the central area, and so the latest plan deviates from previous plans by having a strong decentralisation policy.

The plan makes provision for four major regional centres, each serving 800,000 people, but this does not mean that the existing central business district will not also grow. A major extension planned around Marina Bay draws on examples of other 'world cities', especially those with waterside central areas such as Sydney and San Francisco. The project involves major land reclamation of 667 hectares in total. Part of this has already been developed as a conference and exhibition zone, and the rest will be used for other facilities. However the need for vitality has been recognised and a mixed zoning approach has been adopted, to include housing and entertainment.

One of the new features of the current plan is a broader conception of what contributes to economic success. It encompasses high quality residential provision, a good environment, leisure facilities and exciting city life. Thus there is more provision for low-density housing, often in waterfront communities linked to beaches and recreational facilities. However, the lower housing densities will put considerable pressure on the very limited land available for development, and this creates problems for another of the plan's aims, which is to stress environmental quality. More and more of the remaining open area will be developed, and the only natural landscape surviving will be a small zone in the centre of the island which serves as a water catchment area.

Environmental policy is therefore very much concerned with making the built environment more green by introducing more plants –what is referred to as the 'beautification' of Singapore. The plan focuses on green zones defining the boundaries of settlements, and running along transport corridors. The incidental green provision within housing areas is also given considerable attention.

Much of the environmental provision, for example golf courses, recreation areas, and beaches, is linked to the prime objective of attracting business. The plan places much emphasis on good leisure provision and the need to exploit Singapore's island setting. One way of doing this is through further land reclamation, to create a whole new island devoted to leisure and luxury housing which will stretch from the central area to the airport. A current concern also appears

to be how to use the planning system to create opportunities for greater spontaneity: planners have recently given much attention to the concept of the 24-hour city and the cafe society. For example, a promotion has taken place along the Singapore river to create a café zone. This has included the realisation, rather late in the day, of the value of retaining older buildings, and the creation of a continuous riverside promenade. Since the relaxation in 1996 of strict guidelines on outdoor eating areas, this has become an extremely popular area in the evenings. Also, in 1998 the Urban Redevelopment Authority created a new entertainment area in the centre of the city which they are promoting as ‘the city’s one-stop, dynamic entertainment scene’.

In conclusion, the economic development of Singapore has been very consciously centrally planned, and the latest strategy is very clearly oriented to establishing Singapore as a leading ‘world city’. It is well placed to succeed, for a variety of reasons. It can draw upon its historic roots as a world trading centre; it has invested heavily in telecommunications and air transport infrastructure; it is well located in relation to other Asian economies; it has developed a safe and clean environment; and it has utilised the international language of English.

**Questions 14–19** Complete the summary below using words from the box.  
Singapore

When Singapore became an independent, self-sufficient state it decided to build up its 14....., and government organisations were created to support this policy. However, this initial plan met with limited success due to a shortage of 15..... and land. It was therefore decided to develop the 16..... sector of the economy instead. Singapore is now a leading city, but planners are working to ensure that its economy continues to grow. In contrast to previous policies, there is emphasis on 17..... In addition, land will be recovered to extend the financial district, and provide 18..... as well as housing. The government also plans to improve the quality of Singapore’s environment, but due to the shortage of natural landscapes it will concentrate instead on what it calls 19.....

Decentralisation	fuel	industry	transport	hospitals
loans	deregulation	service	trade	transport
entertainment	recycling	labour	tourism	hygiene
beautification	agriculture			

**Questions 20–26**

Do the following statements agree with the information given in Reading Passage 2? Write

True if the statement agrees with the information

False if the statement contradicts the information

Not Given if there is no information on this.

20. After 1965, the Singaporean government switched the focus of the island’s economy.
21. The creation of Singapore’s financial centre was delayed while a suitable site was found.
22. Singapore’s four regional centres will eventually be the same size as its central business district.
23. Planners have modelled new urban developments on other coastal cities.
24. Plants and trees are amongst the current priorities for Singapore’s city planners.
25. The government has enacted new laws to protect Singapore’s old buildings.
26. Singapore will find it difficult to compete with leading cities in other parts of the world.

**Passage 3**

- A. Spice plants, such as coriander, cardamom or ginger, contain compounds which, when added to food, give it a distinctive flavour. Spices have been used for centuries in the preparation of both meat dishes for consumption and meat dishes for long-term storage. However, an initial analysis of traditional meat-based recipes indicated that spices are not used equally in different countries and regions, so we set about investigating global patterns of spice use.
- B. We hypothesized initially that the benefit of spices might lie in their anti-microbial properties. Those compounds in spice plants which give them their distinctive flavours probably first evolved to fight enemies such as plant-eating insects, fungi, and bacteria. Many of the organisms which afflict spice plants attack humans too, in particular the bacteria and fungi that live on and in dead plant and animal matter. So if spices kill these organisms, or inhibit their production of toxins, spice use in food might reduce our own chances of contracting food poisoning.
- C. The results of our investigation supported this hypothesis. In common with other researchers, we found that all spices for which we could locate appropriate information have some antibacterial effects: half inhibit more than 75% of bacteria, and four (garlic, onion, allspice and oregano) inhibit 100% of those bacteria tested. In addition, many spices are powerful fungicides.
- D. Studies also show that when combined, spices exhibit even greater anti-bacterial properties than when each is used alone. This is interesting because the food recipes we used in our sample specify an average of four different spices. Some spices are so frequently combined that the blends have acquired special names, such as 'chilli powder' (typically a mixture of red pepper, onion, paprika, garlic, cumin and oregano) and 'oriental five spice' (pepper, cinnamon, anise, fennel and cloves). One intriguing example is the French 'quatre epices' (pepper, cloves, ginger and nutmeg) which is often used in making sausages. Sausages are a rich medium for bacterial growth, and have frequently been implicated as the source of death from the botulism toxin, so the value of the anti-bacterial compounds in spices used for sausage preparation is obvious.
- E. A second hypothesis we made was that spice use would be heaviest in areas where foods spoil quickly. Studies indicate that rates of bacterial growth increase dramatically with air temperature. Meat dishes that are prepared in advance and stored at room temperatures for more than a few hours, especially in tropical climates, typically show massive increases in bacterial counts. Of course temperatures within houses, particularly in areas where food is prepared and stored, may differ from those of the outside air, but usually it is even hotter in the kitchen.
- F. Our survey of recipes from around the world confirmed this hypothesis: we found that countries with higher than average temperatures used more spices. Indeed, in hot countries nearly every meat-based recipe calls for at least one spice, and most include many spices, whereas in cooler ones, substantial proportions of dishes are prepared without spices, or with just a few. In other words, there is a significant positive correlation between mean temperature and the average quantity of spices used in cooking.
- G. But if the main function of spices is to make food safer to eat, how did our ancestors know which ones to use in the first place? It seems likely that people who happened to add spice plants to meat during preparation, especially in hot climates, would have been less likely to suffer from food poisoning than those who did not. Spice users may also have been able to store foods for longer before they spoiled, enabling them to tolerate longer periods of scarcity. Observation and imitation of the eating habits of these healthier individuals by others could spread spice use rapidly through a society. Also, families that used appropriate spices would rear a greater number of more healthy offspring, to whom spice-use traditions had been demonstrated, and who possessed appropriate taste receptors.

- H. Another question which arises is why did people develop a taste for spicy foods? One possibility involves learned taste aversions. It is known that when people eat something that makes them ill, they tend to avoid that taste subsequently. The adaptive value of such learning is obvious. Adding a spice to a food that caused sickness might alter its taste enough to make it palatable again (i.e. it tastes like a different food), as well as kill the micro-organisms that caused the illness, thus rendering it safe for consumption. By this process, food aversions would more often be associated with un-spiced (and therefore unsafe) foods, and food likings would be associated with spicy foods, especially in places where foods spoil rapidly. Over time people would have developed a natural preference for spicy food.
- I. Of course, spice use is not the only way to avoid food poisoning. Cooking, and completely consuming wild game immediately after slaughter reduces opportunities for the growth of micro-organisms. However, this is practical only where fresh meat is abundant year-round. In areas where fresh meat is not consistently available, preservation may be accomplished by thoroughly cooking, salting, smoking, drying, and spicing meats. Indeed, salt has been used world wide for centuries to preserve food. We suggest that all these practices have been adopted for essentially the same reason: to minimize the effects of harmful, food-borne organisms.

<sup>1</sup> poisons produced by living organisms, especially bacteria

### Questions 27–33

Reading Passage 3 has nine paragraphs, labelled A–I. Which paragraphs contain the following information?

27. an example of a food which particularly benefits from the addition of spices
28. a range of methods for making food safer to eat .
29. a comparison between countries with different climate types .
30. an explanation of how people first learned to select appropriate spices.
31. a method of enhancing the effectiveness of individual spices .
32. the relative effectiveness of certain spices against harmful organisms .
33. the possible origins of a dislike for un-spiced foods .

### Questions 34–39

Answer the questions below with words taken from Reading Passage 3. Use **NO MORE THAN TWO WORDS** for each answer.

34. According to the writers, what might the use of spices in cooking help people to avoid?
35. What proportion of bacteria in food do four of the spices tested destroy?
36. Which food often contains a spice known as ‘quatre épices’?
37. Which types of country use the fewest number of spices in cooking?
38. What might food aversions often be associated with?
39. Apart from spices, which substance is used in all countries to preserve food?

### Question 40

Choose the correct letter, A, B, C, or D. Which is the best title for Reading Passage 3?

- A. The function of spices in food preparation
- B. A history of food preservation techniques
- C. Traditional recipes from around the world
- D. An analysis of the chemical properties of spice plants



**Academic Reading 5 AC Reading from focusing on IELTS****READING PASSAGE 1****Questions 1 to 7**

Reading Passage 1 has 6 sections A-H. From the list of headings below choose the most suitable heading for sections A-F. Write the appropriate number (i-x) in boxes 1 to 7 on your answer sheet. NB There are more headings than sections so you will not use all of them. You may use any of the headings more than once.

**List of headings**

- (i) The feeding habits of feral cats
- (ii) A pointless campaign
- (iii) Cats: a dangerous pet
- (iv) A more realistic campaign
- (v) An increase in the garden bird population
- (vi) A false belief
- (vii) Ways of controlling feral cats
- (viii) Garden birds: a threatened species
- (ix) Natural predators of birds
- (x) The impossibility of controlling feral cats

**Example****Answer****Section D****(V)**

1. Section A
2. Section B
3. Section C
4. Section E
5. Section F
6. Section G
7. Section H

**Cats - scoundrels or scapegoats?**

- A. The campaign against cats has become so exaggerated it has lost its focus. Much energy that could be put to good use is being wasted on futile campaigns that do little more than aggravate cat owners.
- B. It is widely believed that because cats prey on native birds they could bring about their extermination. But predation seldom leads to extinction in such a simplistic way. If it did there would be no animals left in Africa, as those big cats called Lions would have eaten them all up.
- C. Enormous numbers of birds are killed by pet cats in gardens, it is true. But while this may sound alarming, ecologically there is nothing wrong with it - predation is a fact of life. Birds are killed in forests too, by a whole gamut of predators including snakes, goannas, falcons, butcherbirds, quolls, dingoes and even spiders. Pet cats are the urban counterparts to a range of native predators.
- D. Hunting by pet Cats would only be a problem if the rate of predation, combined with other deaths, exceeded the breeding rate of the birds. This does not seem to be the case. Several studies show that urban environments actually support a higher density of birds than native forests, despite all the cats. This is partly because of all the garden plants with berries and nectar rich flowers.
- E. The native garden birds killed by cats are nearly all widespread adaptable species that are thriving in response to urbanisation. Some of them are probably more abundant now

than they were before European settlement. This definitely seems to be the case for the common garden skinks that cats often kill.

- F. Feral cats are a much greater threat to wildlife than pet cats, and in some situations they are a major hazard. But not usually to birds, which they seldom eat. Studies of their diet confirm what cartoonists have always known: that cats prefer rats, mice and other small mammals. In a major article on cats (*Nature Australia*, Winter 1993) Chris Dickman stated: 'In most Australian studies, rabbits constitute the single most important prey.'
- G. I would suggest that foxes pose a greater problem, yet there is no passionate public campaign to oust foxes, presumably because it is obvious we can never eliminate the millions of wild foxes in Australia. Yet the same common sense thinking is not applied to cats. It is thought instead that, if everyone would only spay their cats, string bells around their necks and keep them in at night, cats would no longer kill wildlife. But what of the millions of feral cats in our deserts and woodlands? They are the bigger problem, but they are no more controllable than foxes or cane toads.
- H. To be useful, the anti-cat campaign should focus on specific situations where cats are a proven problem, and where something can actually be done about it. But to make the sweeping claim that 'Cats threaten the future survival of most wildlife', as the Victorian Department of Environment does in a leaflet, is to exaggerate the case so badly that it probably does more harm than good, by pitting cat owners against conservationists, instead of bringing them together as allies.

*Tim Low, Nature Australia, Autumn 1996*

### Questions 8 to 13

Do the following statements reflect the claims of the writer of Reading Passage 1. Write:

- |           |  |
|-----------|--|
| YES       | if the statement agrees with the writer              |
| NO        | if the statement contradicts the writer              |
| NOT GIVEN | if there is no information about this in the passage |
8. The activity of predators, such as lions, causes extinction of other animals.
  9. Other animals eat more birds than cats.
  10. There are more birds per kilometre in towns and cities than in a forest environment.
  11. The large number of plants in gardens has helped to increase the bird population.
  12. The author believes that all wild foxes should be killed.
  13. Cats are a particular problem in Victoria.

### READING PASSAGE 2

You should spend about 20 minutes on questions 14 to 26.

## **Does an aging society mean an aging culture?**

Especially in the United States, the developed world's obsession with newness, progress and the future has always derived its energy from the numerical heft of each new rising generation. As recently as 1970, when a new youth culture redefined the American dream, the US median age was only 28 — not much higher than the median (about age 18 to 20,) of the typical pre-modern society. Today with the US median age hitting an unprecedented 35, the American public hears a lot less about the ideals of youth than about the worries of the middle-aged and old.

And this is just the beginning: by the year 2030, the median age will reach at least 40 in the United States and at least the late +0s in much of Europe. Back when America's baby boomers were warning each other. 'Don't trust anyone over 30', Americans over 30 were

in the minority. Over the foreseeable future, they are certain to remain in a solid majority. By the year 2030, over one-half of all adults will be aged 50 and over — and thus eligible to join AARP (the American association of retired persons). While this 50 and over crowd will outnumber all younger adults in the United States, in some European countries it will out-number all younger adults and all children.

What do these numbers mean for our culture? Clearly, they mean a much greater focus on the interests and activities of the old over those of the young. For decades, the mass media in the United States and around the world — TV, movies, popular music, and radio — have aggressively courted the all important under 50 demographic. How will the business, as well as the substance, of popular culture change as it becomes evident that the elderly represent the fastest growing component of the total population and youth the fastest shrinking one?

We should not be surprised to see pension issues eclipsing college issues on the front pages of newspapers. Yet the numbers may have a deeper influence. Along with experience and wisdom, it has long been observed that old age brings with it an aversion to risk and change. Cicero put it this way: ‘young men for action, old men for counsel’. As people age, moreover, the formative era that shaped their education and outlook becomes ever more remote in time — making them seem, in a changing world, increasingly ‘out of date’ from the perspective of youth.

As the entire population of the developed world grows older, the attributes of personal aging may come to define the tone and pace of the culture at large.

Part of this tone may be a general slowing down of the pace of social life. As social scientist Andrew Hacker observes, ‘Have you noticed how much longer it takes New York buses to get going, since elderly passengers take so much longer boarding and leaving? Or the wait at your bank and post office, when the aged person at the window doesn’t understand what he/she is being told?’

**The impact of fewer young people**

The shrinking of the average family may reinforce the aging of culture. In a world of steadily falling fertility a growing share of the population will consist of first born and only children. First born children, many social scientists say, are typically more conservative in their social outlook than later-born siblings. According to historian Frank Holloway, ‘First borns are less open to innovation, they tend to be more conforming, more traditional and more closely allied with their parents.’

Another possibility is that smaller families may make society less willing to put its youth at risk in national emergencies such as war. In past generations, families who lost a son in battle could usually take solace in the survival of his brother, and indeed governments have sometimes exempted only sons from war time service. In the coming decades, will developed societies be willing to place their scarce youth in harms way to defend national interests?

*Peter G Peterson, ‘World future society’ 19, The Futurist, Jan-Feb 2000*

**Questions 14 to 20**

Complete the summary of the first two paragraphs of Reading Passage 2 above.

Choose your answers from the box below the summary and write them in boxes 14-20 of your answer sheet. NB There are more words/phrases or numbers than you will need to fill in the gaps. You may use a word or a phrase more than once.

### Summary

The 14.....has always looked towards the future because most people were young. The average age of Americans in 1970 was 15..... compared to 16.....in developing countries.

In the future, Americans over 30 will form a 17..... It is therefore likely that governments will be more concerned with 18..... In 2030, over 50% of 19..... of some countries in Europe and 50% of 20.....in America will be over 50 years old.

Developed world 35 28	the population 18-20 Special interest group	all adults majority the aged	all adults and children minority developing world
-----------------------------	---	------------------------------------	---

### Questions 21 to 26

Choose the letter that most closely describes the author's viewpoint A-D for each question and then write the appropriate letter in boxes 21 to 26 on your answer sheet.

21. The aging population
  - A. has changed the face of popular culture.
  - B. will change the type of music we listen to.
  - C. will mean a rise in pensions.
  - D. could change the face of popular culture.
22. An aging population may make society
  - A. out of touch.
  - B. risky and changeable.
  - C. more cultured.
  - D. remote.
23. According to the author the pace of future society is likely to
  - A. speed up.
  - B. remain the same.
  - C. become slower.
  - D. be difficult to predict.
24. other factor which may age culture is .....
  - A. reduced fertility
  - B. the length of time needed to perform simple tasks.
  - C. more wisdom.
  - D. an old fashioned education system.
25. First born children are
  - A. less willing to take risks in time of national emergency
  - B. likely to support their parents views.
  - C. always more conservative than their siblings.
  - D. unlikely to be asked to fight in future wars.
26. An aging society is likely to happen
  - A. in America.
  - B. in America and Europe.
  - C. everywhere.
  - D. in developing countries.

## READING PASSAGE 3

**Short shrift**

The benefits of employing part-time staff are well known, but little has been done to improve the quality of, or access to part-time work.

The long awaited consultation document on part-time work had the potential to tackle the long hours culture, underpin the government's family friendly stance and encourage flexibility in the labour market, but the reality is disappointing. Opting for a light touch, the regulations fail to improve the quality of part-time work or to aid the development of part-time work on a voluntary basis.

More than six million people (a quarter of the workforce) work part-time, including nearly one million men. Two categories — wholesale, retail and motor trade, and health and social work account for 45 percent of part-time jobs, with many more in the hospitality industry. The increase in part-time work has been a major feature of employment trends in the past decade, but most jobs remain low-paid and low in status.

Many employers already acknowledge the key role that part-time work plays in employment strategies. Tesco, for example is on record as describing its part-time workforce — which makes up 65% of the total — as the 'lifeblood' of the organisation. Labour supplies can be tailored to trading peaks and demand for ever longer trading hours.

Furthermore, specialist jobs do not always require full-time cover, particularly in smaller organisations. Christine Pointer, a chief executive with a local authority who works with limited budgets, finds it better to employ a more senior professional on a part-time basis, rather than a less qualified person full-time. Part-time work at senior levels also helps to retain key staff who might otherwise leave the organisation.

Unfortunately, not all employers recognise these potential benefits. In the health service for example, where few such opportunities exist, many doctors leave despite the high cost to the state of training them. And the insurance sector has lower levels of part-time working than any other area of financial services.

Sadly the widespread view that part-time work is primarily attractive to women with caring responsibilities is reinforced both by legislature and organizational culture. The growing trend for men to seek a better work/home balance is being ignored. Women have managed to negotiate limited access to part-time work at senior levels on the back of equal opportunities legislation. But the assumption remains that there is something odd about men who want to work part-time — they lack ambition and commitment to their employer.

Disabled employees represent a large proportion of the workforce that could benefit from part-time work. The labour force identifies over two million economically active people with a long term health problem or disability. It also shows that nearly fifteen million people of working age judge themselves to be covered by the Disabilities Discriminations Act's definition of disability. This includes almost one million who are not working but would like to. For many of them, part-time work is the simplest 'reasonable adjustment' that an employer can make.

On access to training for part-timers, the consultation document again disappoints. While placing an obligation on employers not to exclude part-timers in principle, there is no legal requirement to structure training to accommodate them. New technologies can and do provide flexible access to training — making this omission inexcusable. Ironically the government is on record as saying that competitiveness depends on the UK making the best use of the talents of as many people as possible and that the larger the number of people to which business can look, the better. However, little is done to encourage the development of these talents in the workforce.

Similarly nothing has been done to alter the perception of part-time work is a 'woman's issue'. A recent press release states 'the new measures will simplify the legal position for part-timers — 80% of whom are women — who will no longer have to go down the indirect route of claiming discrimination under the sex discrimination act'. Wonderful! But occupational segregation is still maintained by gender.

*Anna Allen People management February 2000.*

### Questions 27-32

Choose one phrase from the box to complete each of the following key points. Write the appropriate letters A-I in boxes 27 to 32 on your answer sheet. NB – There are more phrases than key points so you will not use all of them. You may use any of the headings more than once.

#### List of phrases

- A. Many of them are voluntary.
- B. Most of them are poorly paid.
- C. They don't have to provide training at appropriate times.
- D. If they want to work part-time.
- E. If they can't work part time.
- F. Would like to work
- G. Part-time senior professionals.
- H. Wouldn't be able to work full-time.
- I. Less qualified full-time employees.
- J. People would prefer to work full-time.
- K. Part-time female employees.
- L. They don't have to offer training to part-timers.

#### Example

#### Answer

Many employees

H

27. Although there are many more part-time jobs,

28. Often smaller organisations prefer to hire

29. Senior staff might leave the organisation,

30. Men are thought to lack ambition,

31. Nearly one million disabled people

32. Although employers are required not to discriminate against part-timers,

### Questions 33 to 40

Using **NO MORE THAN THREE WORDS**, complete the following statements.

Write your answers in boxes 33 to 40 on your answer sheet.

Part-time employees can adapt to 33..... better than full time staff.

Many organisations assume that part-time work is only attractive to 34.....

Part-time work is available for women at senior levels because of 35.....

Men who want to work part-time are considered to 36.....

Employers could help 37.....to find work by allowing them to work part-time.

New technology has made access to training 38.....

Despite statements to the contrary, part-time work is still seen as a 39.....

The new legislation is designed to make 40.....of part-timers clearer.

## Reading 6

British Council Complete test from Take ielts

## READING PASSAGE 1

**MAKING TIME FOR SCIENCE**

Chronobiology might sound a little futuristic – like something from a science fiction novel, perhaps – but it's actually a field of study that concerns one of the oldest processes life on this planet has ever known: short-term rhythms of time and their effect on flora and fauna.

This can take many forms. Marine life, for example, is influenced by tidal patterns. Animals tend to be active or inactive depending on the position of the sun or moon. Numerous creatures, humans included, are largely diurnal – that is, they like to come out during the hours of sunlight. Nocturnal animals, such as bats and possums, prefer to forage by night. A third group are known as crepuscular: they thrive in the lowlight of dawn and dusk and remain inactive at other hours.

When it comes to humans, chronobiologists are interested in what is known as the circadian rhythm. This is the complete cycle our bodies are naturally geared to undergo within the passage of a twenty-four hour day. Aside from sleeping at night and waking during the day, each cycle involves many other factors such as changes in blood pressure and body temperature. Not everyone has an identical circadian rhythm. 'Night people', for example, often describe how they find it very hard to operate during the morning, but become alert and focused by evening. This is a benign variation within circadian rhythms known as a chronotype.

Scientists have limited abilities to create durable modifications of chronobiological demands. Recent therapeutic developments for humans such as artificial light machines and melatonin administration can reset our circadian rhythms, for example, but our bodies can tell the difference and health suffers when we breach these natural rhythms for extended periods of time. Plants appear no more malleable in this respect; studies demonstrate that vegetables grown in season and ripened on the tree are far higher in essential nutrients than those grown in greenhouses and ripened by laser.

Knowledge of chronobiological patterns can have many pragmatic implications for our day-to-day lives. While contemporary living can sometimes appear to subjugate biology – after all, who needs circadian rhythms when we have caffeine pills, energy drinks, shift work and cities that never sleep? – keeping in synch with our body clock is important.

The average urban resident, for example, rouses at the eye-blearing time of 6.04 a.m., which researchers believe to be far too early. One study found that even rising at 7.00 a.m. has deleterious effects on health unless exercise is performed for 30 minutes afterward. The optimum moment has been whittled down to 7.22 a.m.; muscle aches, headaches and moodiness were reported to be lowest by participants in the study who awoke then.

Once you're up and ready to go, what then? If you're trying to shed some extra pounds, dieticians are adamant: never skip breakfast. This disorients your circadian rhythm and puts your body in starvation mode. The recommended course of action is to follow an intense workout with a carbohydrate-rich breakfast; the other way round and weight loss results are not as pronounced.

Morning is also great for breaking out the vitamins. Supplement absorption by the body is not temporal-dependent, but naturopath Pam Stone notes that the extra boost at breakfast helps us get energised for the day ahead. For improved absorption, Stone suggests pairing supplements with a food in which they are soluble and steering clear of caffeinated beverages. Finally, Stone warns to take care with storage; high potency is best for absorption, and warmth and humidity are known to deplete the potency of a supplement.

After-dinner espressos are becoming more of a tradition – we have the Italians to thank for that – but to prepare for a good night's sleep we are better off putting the brakes on caffeine

consumption as early as 3 p.m. With a seven hour half-life, a cup of coffee containing 90 mg of caffeine taken at this hour could still leave 45 mg of caffeine in your nervous system at ten o'clock that evening. It is essential that, by the time you are ready to sleep, your body is rid of all traces.

Evenings are important for winding down before sleep; however, dietician Geraldine Georgeou warns that an after-five carbohydrate-fast is more cultural myth than chronobiological demand. This will deprive your body of vital energy needs. Overloading your gut could lead to indigestion, though. Our digestive tracts do not shut down for the night entirely, but their work slows to a crawl as our bodies prepare for sleep. Consuming a modest snack should be entirely sufficient.

#### Questions 1–7

Do the following statements agree with the information given in Reading Passage 1? Write

TRUE if the statement agrees with the information

FALSE if the statement contradicts the information

NOT GIVEN if there is no information on this

1. Chronobiology is the study of how living things have evolved over time.
2. The rise and fall of sea levels affects how sea creatures behave.
3. Most animals are active during the daytime.
4. Circadian rhythms identify how we do different things on different days.
5. A 'night person' can still have a healthy circadian rhythm.
6. New therapies can permanently change circadian rhythms without causing harm.
7. Naturally-produced vegetables have more nutritional value.

#### Questions 8–13

Choose the correct letter, A, B, C or D.

8. What did researchers identify as the ideal time to wake up in the morning?
  - A. 6.04
  - B. 7.00
  - C. 7.22
  - D. 7.30
9. In order to lose weight, we should
  - A. avoid eating breakfast
  - B. eat a low carbohydrate breakfast
  - C. exercise before breakfast
  - D. exercise after breakfast
10. Which is NOT mentioned as a way to improve supplement absorption?
  - A. avoiding drinks containing caffeine while taking supplements
  - B. taking supplements at breakfast
  - C. taking supplements with foods that can dissolve them
  - D. storing supplements in a cool, dry environment
11. The best time to stop drinking coffee is
  - A. mid-afternoon
  - B. 10 p.m.
  - C. only when feeling anxious
  - D. after dinner
12. In the evening, we should
  - A. stay away from carbohydrates
  - B. stop exercising
  - C. eat as much as possible
  - D. eat a light meal
13. Which of the following phrases best describes the main aim of Reading Passage 1?
  - A. to suggest healthier ways of eating, sleeping and exercising
  - B. to describe how modern life has made chronobiology largely irrelevant
  - C. to introduce chronobiology and describe some practical applications
  - D. to plan a daily schedule that can alter our natural chronobiological rhythms



## READING PASSAGE 2

**The Triune<sup>1</sup> Brain**

The first of our three brains to evolve is what scientists call the reptilian cortex. This brain sustains the elementary activities of animal survival such as respiration, adequate rest and a beating heart. We are not required to consciously “think” about these activities. The reptilian cortex also houses the “startle centre”, a mechanism that facilitates swift reactions to unexpected occurrences in our surroundings. That panicked lurch you experience when a door slams shut somewhere in the house, or the heightened awareness you feel when a twig cracks in a nearby bush while out on an evening stroll are both examples of the reptilian cortex at work. When it comes to our interaction with others, the reptilian brain offers up only the most basic impulses: aggression, mating, and territorial defence. There is no great difference, in this sense, between a crocodile defending its spot along the river and a turf war between two urban gangs.

Although the lizard may stake a claim to its habitat, it exerts total indifference toward the well-being of its young. Listen to the anguished squeal of a dolphin separated from its pod or witness the sight of elephants mourning their dead, however, and it is clear that a new development is at play. Scientists have identified this as the limbic cortex. Unique to mammals, the limbic cortex impels creatures to nurture their offspring by delivering feelings of tenderness and warmth to the parent when children are nearby. These same sensations also cause mammals to develop various types of social relations and kinship networks. When we are with others of “our kind” – be it at soccer practice, church, school or a nightclub – we experience positive sensations of togetherness, solidarity and comfort. If we spend too long away from these networks, then loneliness sets in and encourages us to seek companionship.

Only human capabilities extend far beyond the scope of these two cortexes. Humans eat, sleep and play, but we also speak, plot, rationalise and debate finer points of morality. Our unique abilities are the result of an expansive third brain – the neocortex – which engages with logic, reason and ideas. The power of the neocortex comes from its ability to think beyond the present, concrete moment. While other mammals are mainly restricted to impulsive actions (although some, such as apes, can learn and remember simple lessons), humans can think about the “big picture”. We can string together simple lessons (for example, an apple drops downwards from a tree; hurting others causes unhappiness) to develop complex theories of physical or social phenomena (such as the laws of gravity and a concern for human rights).

The neocortex is also responsible for the process by which we decide on and commit to particular courses of action. Strung together over time, these choices can accumulate into feats of progress unknown to other animals. Anticipating a better grade on the following morning’s exam, a student can ignore the limbic urge to socialise and go to sleep early instead. Over three years, this ongoing sacrifice translates into a first class degree and a scholarship to graduate school; over a lifetime, it can mean groundbreaking contributions to human knowledge and development. The ability to sacrifice our drive for immediate satisfaction in order to benefit later is a product of the neocortex.

Understanding the triune brain can help us appreciate the different natures of brain damage and psychological disorders. The most devastating form of brain damage, for

example, is a condition in which someone is understood to be brain dead. In this state a person appears merely unconscious – sleeping, perhaps – but this is illusory. Here, the reptilian brain is functioning on autopilot despite the permanent loss of other cortexes.

Disturbances to the limbic cortex are registered in a different manner. Pups with limbic damage can move around and feed themselves well enough but do not register the presence of their littermates. Scientists have observed how, after a limbic lobotomy<sup>2</sup>, “one impaired monkey stepped on his outraged peers as if treading on a log or a rock”. In our own species, limbic damage is closely related to sociopathic behaviour. Sociopaths in possession of fully-functioning neocortexes are often shrewd and emotionally intelligent people but lack any ability to relate to, empathise with or express concern for others.

One of the neurological wonders of history occurred when a railway worker named Phineas Gage survived an incident during which a metal rod skewered his skull, taking a considerable amount of his neocortex with it. Though Gage continued to live and work as before, his fellow employees observed a shift in the equilibrium of his personality. Gage’s animal propensities were now sharply pronounced while his intellectual abilities suffered; garrulous or obscene jokes replaced his once quick wit. New findings suggest, however, that Gage managed to soften these abrupt changes over time and rediscover an appropriate social manner. This would indicate that reparative therapy has the potential to help patients with advanced brain trauma to gain an improved quality of life.

1 Triune = three-in-one

2 Lobotomy = surgical cutting of brain nerves

#### Questions 14–22

Classify the following as typical of

- A. the reptilian cortex
- B. the limbic cortex
- C. the neocortex

Write the correct letter, A, B or C, in boxes 14–22 on your answer sheet.

14. giving up short-term happiness for future gains
15. maintaining the bodily functions necessary for life
16. experiencing the pain of losing another
17. forming communities and social groups
18. making a decision and carrying it out
19. guarding areas of land
20. developing explanations for things
21. looking after one’s young
22. responding quickly to sudden movement and noise

#### Questions 23–26

Complete the sentences below. Write NO MORE THAN TWO WORDS from the passage for each answer. Write your answers in boxes 23–26 on your answer sheet.

23. A person with only a functioning reptilian cortex is known as .....
24. .... in humans is associated with limbic disruption.
25. An industrial accident caused Phineas Gage to lose part of his .....
26. After his accident, co-workers noticed an imbalance between Gage’s ..... and higher-order thinking.

## READING PASSAGE 3

**HELIUM'S FUTURE UP IN THE AIR**

- A. In recent years we have all been exposed to dire media reports concerning the impending demise of global coal and oil reserves, but the depletion of another key nonrenewable resource continues without receiving much press at all. Helium – an inert, odourless, monatomic element known to lay people as the substance that makes balloons float and voices squeak when inhaled – could be gone from this planet within a generation.
- B. Helium itself is not rare; there is actually a plentiful supply of it in the cosmos. In fact, 24 per cent of our galaxy's elemental mass consists of helium, which makes it the second most abundant element in our universe. Because of its lightness, however, most helium vanished from our own planet many years ago. Consequently, only a miniscule proportion – 0.00052%, to be exact – remains in earth's atmosphere. Helium is the byproduct of millennia of radioactive decay from the elements thorium and uranium. The helium is mostly trapped in subterranean natural gas bunkers and commercially extracted through a method known as fractional distillation.
- C. The loss of helium on Earth would affect society greatly. Defying the perception of it as a novelty substance for parties and gimmicks, the element actually has many vital applications in society. Probably the most well known commercial usage is in airships and blimps (non-flammable helium replaced hydrogen as the lifting gas *du jour* after the Hindenburg catastrophe in 1932, during which an airship burst into flames and crashed to the ground killing some passengers and crew). But helium is also instrumental in deep-sea diving, where it is blended with nitrogen to mitigate the dangers of inhaling ordinary air under high pressure; as a cleaning agent for rocket engines; and, in its most prevalent use, as a coolant for superconducting magnets in hospital MRI (magnetic resonance imaging) scanners.
- D. The possibility of losing helium forever poses the threat of a real crisis because its unique qualities are extraordinarily difficult, if not impossible to duplicate (certainly, no biosynthetic ersatz product is close to approaching the point of feasibility for helium, even as similar developments continue apace for oil and coal). Helium is even cheerfully derided as a “loner” element since it does not adhere to other molecules like its cousin, hydrogen. According to Dr. Lee Sobotka, helium is the “most noble of gases, meaning it's very stable and non-reactive for the most part ... it has a closed electronic configuration, a very tightly bound atom. It is this coveting of its own electrons that prevents combination with other elements'. Another important attribute is helium's unique boiling point, which is lower than that for any other element. The worsening global shortage could render millions of dollars of high-value, life-saving equipment totally useless. The dwindling supplies have already resulted in the postponement of research and development projects in physics laboratories and manufacturing plants around the world. There is an enormous supply and demand imbalance partly brought about by the expansion of high-tech manufacturing in Asia.
- E. The source of the problem is the Helium Privatisation Act (HPA), an American law passed in 1996 that requires the U.S. National Helium Reserve to liquidate its helium assets by 2015 regardless of the market price. Although intended to settle the original cost of the reserve by a U.S. Congress ignorant of its ramifications, the result of this fire sale is that global helium prices are so artificially deflated that few can be bothered recycling the substance or using it judiciously. Deflated values also mean that natural gas extractors see no reason to capture helium. Much is lost in the process of extraction. As Sobotka notes: “[t]he government had the good vision to store helium, and the question now is: Will the corporations have the vision to

capture it when extracting natural gas, and consumers the wisdom to recycle? This takes long-term vision because present market forces are not sufficient to compel prudent practice". For Nobel-prize laureate Robert Richardson, the U.S. government must be prevailed upon to repeal its privatisation policy as the country supplies over 80 per cent of global helium, mostly from the National Helium Reserve. For Richardson, a twenty- to fifty-fold increase in prices would provide incentives to recycle.

- F. A number of steps need to be taken in order to avert a costly predicament in the coming decades. Firstly, all existing supplies of helium ought to be conserved and released only by permit, with medical uses receiving precedence over other commercial or recreational demands. Secondly, conservation should be obligatory and enforced by a regulatory agency. At the moment some users, such as hospitals, tend to recycle diligently while others, such as NASA, squander massive amounts of helium. Lastly, research into alternatives to helium must begin in earnest.

#### Questions 27–31

Reading Passage 3 has six paragraphs, A–F. Which paragraph contains the following information?

27. a use for helium which makes an activity safer
28. the possibility of creating an alternative to helium
29. a term which describes the process of how helium is taken out of the ground
30. a reason why users of helium do not make efforts to conserve it
31. a contrast between helium's chemical properties and how non-scientists think about it

#### Questions 32–35

Do the following statements agree with the claims of the writer in Reading Passage 3?

Write

- |           |  |
|-----------|--|
| YES       | if the statement agrees with the claims of the writer        |
| NO        | if the statement contradicts the claims of the writer        |
| NOT GIVEN | if it is impossible to say what the writer thinks about this |

32. Helium chooses to be on its own.
33. Helium is a very cold substance.
34. High-tech industries in Asia use more helium than laboratories and manufacturers in other parts of the world.
35. The US Congress understood the possible consequences of the HPA.

#### Questions 36–40

Complete the summary below. Choose **NO MORE THAN TWO WORDS** from the passage for each answer. Write your answers in boxes 36–40 on your answer sheet.

Sobotka argues that big business and users of helium need to help look after helium stocks because 36 ..... will not be encouraged through buying and selling alone. Richardson believes that the 37 ..... needs to be withdrawn, as the U.S. provides most of the world's helium. He argues that higher costs would mean people have 38 ..... to use the resource many times over. People should need a 39 ..... to access helium that we still have. Furthermore, a 40 ..... should ensure that helium is used carefully.

**Reading 7**                      **KAPLANS READING (AC)**  
**READING PASSAGE 1**

Gender selection-the choosing of a baby's gender prior to birth-occurs in many parts of the world. In China and India, for example, a baby's gender is considered to be of vital importance to the family, and male babies are often preferred over females for cultural reasons. In western countries as well, there are many reasons why a family might want to choose a baby's sex. Often parents wish to have a mix of both boys and girls in the family. There are also health reasons for gender selection: many diseases affect children of only one sex and a family that is susceptible to these diseases may wish to choose a baby's gender to avoid having an affected child.

This demand for gender choice for parents has led scientists worldwide to investigate gender selection prior to conception. Conventional wisdom states that the father's sperm is the main determinant of the child's gender, but recent research has begun to reveal a number of other possible determining factors.

Elissa Cameron's 2007 research at the African University of Pretoria investigated the effects of diet on sex ratios at birth. In one experiment, she changed the blood sugar level of female mice prior to conception by putting a chemical in the animals' water. Mice that received the additive saw their blood sugar levels fall from 6.47 to 5.24 millimols/litre. A separate control group of mice received pure water, without the additive. After a few days, the two groups of mice were allowed to mate. In the control group, 41 % of the mice were born female, as compared to 47% in the group that received the additive-a disparity that Dr Cameron ascribed to the differences in the mothers' blood sugar levels.

Interestingly, the idea that blood sugar levels affect a baby's sex follows traditional wisdom. It has long been believed that mothers should eat more red meat and salty foods-which raise blood sugar for a long period-if they want to have a boy; they are advised to eat chocolates and sweets-which raise blood sugar levels for a short time only-if they want a girl.

Another researcher in this field, Fiona Matthews of the University of Exeter, England, has come up with further evidence in support of the effect of diet on the sex of the unborn child. Her study followed 740 pregnant women who kept detailed records of their diets before conception. Her study found that mothers who consumed high-energy foods prior to conception were slightly more likely to have boys. The food with the greatest effect seemed to be breakfast cereals, which tend to be high in energy and often high in sodium content as well. Among women eating cereals on a daily basis, 59% had boys, compared with 43% of women who ate less than one bowl of breakfast cereal per week. These results are said to echo those seen in other animals, for example horses and cows, which statistically bear more males when well-fed.

The eating habits of women in rich western countries could explain the slight fall in male births that has been reported over the past several years. In the UK, male births are falling by 1 per 1,000 births per year. This could be ascribed to the decline in the number of adults and adolescent girls eating breakfast on a regular basis. In addition, the popularity of low-calorie diets for females of child-bearing age could also be a factor contributing to the reduction in male births.

The recent decline in male births in western countries appears to make sense if one looks at it from an evolutionary standpoint. Historically, more boys tend to be born in times of food plenty, while females tend to be born in times of scarcity. One explanation is that when food is scarce, it is better for the survival of the species for female children to be born-as one male can father offspring by many females. Lower-calorie diets among western women could be biologically echoing the effects of scarcity-hence, the decline in male births.

So what can we conclude from this complicated picture? If you would like to have a son, it might be a good idea to eat a breakfast that includes cereal. On the other hand, if you would prefer to give birth to a daughter, then cut out breakfast and continue a weight reduction diet at least until after conception.

### Questions 1 - 8

Do the following statements agree with the information given in Reading Passage 1? Write

TRUE if the statement agrees with the information  
 FALSE if the statement contradicts the information  
 NOT GIVEN if there is no information on this

1. Mothers in India eat cereals for breakfast so that they will have male babies.
2. New drugs have been developed that allow parents to choose the sex of their child.
3. People used to think that the father was responsible for the sex of the baby.
4. Elissa Cameron used both humans and mice in her research.
5. The majority of research on gender selection is happening in Europe.
6. People in the United Kingdom often do not eat breakfast.
7. Some people think that drinking tea has an effect on the sex of a baby.
8. High-calorie diets have been shown to increase the likelihood of female births.

### Questions 9 - 13

Complete each sentence with the correct ending, A-K, below. Write the correct letter, A-K, in boxes 9-13 on your answer sheet.

9. Elissa Cameron
  10. In western countries, gender selection
  11. Fiona Matthews
  12. Evolution seems to support
  13. Eating breakfast cereal on a daily basis
- A. artificially decreased the blood sugar levels of mice.  
 B. is often based on cultural preferences.  
 C. asked patients to write down everything that they ate and when they ate it.  
 D. the influence of food scarcity upon sex ratios at birth.  
 E. that adding sodium to food affects the sex of a baby.  
 F. is an American scientist.  
 G. sometimes occurs for health reasons.  
 H. an equal balance between male and female children.  
 I. conducted research on horses and cows.  
 J. is more common in the UK than in other western countries.  
 K. seems to increase the likelihood of male births.

### Question 14

Choose the correct letter, A, B, C, D or E.

Write your answer in box 14 on your answer sheet.

Which of the following is the most suitable title for Reading Passage 1?

- A. Eating Cereal is Good for Pregnant Women
- B. Research Says Mice Make Better Mothers
- C. Diet May Influence the Sex of Your Baby
- D. Asian Research Influences Western Medicine
- E. Gender Selection Research Sparks Scientific Debate

## READING PASSAGE 2

**The Disease Multiple Sclerosis**

- A. Multiple Sclerosis (MS) is a disease in which the patient's immune system attacks the central nervous system. This can lead to numerous physical and mental symptoms, as the disease affects the transmission of electrical signals between the body and the brain. However, the human body, being a flexible, adaptable system, can compensate for some level of damage, so a person with MS can look and feel fine even though the disease is present.
- B. MS patients can have one of two main varieties of the disease: the relapsing form and the primary progressive form. In the relapsing form, the disease progresses in a series of jumps; at times it is in remission, which means that a person's normal functions return for a period of time before the system goes into relapse and the disease again becomes more active. This is the most common form of MS; 80-90% of people have this form of the disease when they are first diagnosed. The relapse-remission cycle can continue for many years. Eventually, however, loss of physical and cognitive functions starts to take place and the remissions become less frequent.
- C. In the primary progressive form of MS, there are no remissions and a continual but steady loss of physical and cognitive functions takes place. This condition affects about 10-15% of sufferers at diagnosis.
- D. The expected course of the disease, or prognosis, depends on many variables: the subtype of the disease, the patient's individual characteristics and the initial symptoms. Life expectancy of patients, however, is often nearly the same as that of an unaffected person-provided that a reasonable standard of care is received. In some cases a near-normal life span is possible.
- E. The cause of the disease is unclear; it seems that some people have a genetic susceptibility, which is triggered by some unknown environmental factor. Onset of the disease usually occurs in young adults between the ages of 20 and 40. It is more common in women than men; however, it has also been diagnosed in young children and in elderly people.
- F. Hereditary factors have been seen to have some relevance. Studies of identical twins have shown that if one twin has the disease, then it is likely that the other twin will develop it. In addition, it is important to realise that close relatives of patients have a higher chance of developing the disease than people without a relative who has MS.
- G. Where people live can be seen to have a clear effect, as MS does not occur as frequently in every country. It commonly affects Caucasian people, particularly in North America, Europe and Australia. It has been recognised that MS is more common the further the country is away from the equator, and the incidence of MS is generally much higher in northern countries with temperate climates than in warmer southern countries.
- H. Three things, which do not normally occur in healthy people, happen to people who have MS. First, tiny patches of inflammation occur in the brain or spinal chord. Second, the protective coating around the axons, or nerve fibres, in the body starts to deteriorate. Third, the axons themselves become damaged or destroyed. This can lead to a wide range of symptoms in the patient, depending on where the affected axons are located.
- I. A common symptom of MS is blurred vision, caused by inflammation of the optic nerve. Another sign is loss of muscle tone in arms and legs; this is when control of muscle

movement, or strength in the arms or legs, can be lost. Sense of touch can be lost, so that the body is unable to feel heat or cold, or the sufferer experiences temperature inappropriately, that is, feeling heat when it is cold and vice versa. Balance can also be affected; some people may eventually have to resort to a wheel-chair, either on a permanent or temporary basis. The course of the disease varies from person to person.

- J. A diagnosis of MS is often confirmed by the use of a Magnetic Resonance Imaging (MRI) scan, which can show defects in the brain and spinal chord. Once diagnosed, MS is a lifelong disease; no cure exists, although a number of medical treatments have been shown to reduce relapses and slow the progression of the disease. It is important that patients with the disease are diagnosed early, so that treatment, which can slow the disease, can be started early.

**Questions 15 - 19**

Reading passage 2 has 10 paragraphs labelled A-J. Which paragraph contains the following information? Write the correct letters, A-J, in boxes 15-19 on your answer sheet. N B You may use any letter more than once.

- 15. The main types of the disease
- 16. Loss of the sense of feeling
- 17. The progress of the disease
- 18. Treatments for the disease
- 19. The effects of geography

**Questions 20 - 27**

Complete the table below. Choose **NO MORE THAN THREE WORDS** from the passage for each answer. Write your answers in boxes 20-27 on your answer sheet.

Main Types of 20 .....		
21 ..... 80-90% of sufferers	Primary Progressive Form 22 ..... of patients	
Causes are unclear		
23 ..... 24 ..... people are more often affected than other races. There is a higher incidence where the weather is 25.....	Hereditary If one 26 ..... is affected the other is likely to develop MS.	
Three effects of MS		
Inflammation in the brain and/or 27 .....	Coating of nerve fibres damaged	Axons themselves damaged.

**READING PASSAGE 3**

**Surge Protection**

With more and more devices connecting to the world's electrical networks, protecting electrical systems and devices from power surges-also known as distribution overcurrent - has become more important than ever. Without adequate overcurrent protection, interruptions to electrical service can have catastrophic effects on individuals, cities and entire nations.

In a normal electrical system, customers are supplied with a steady electrical current-a predetermined voltage necessary to safely operate all electrical equipment connected to that system. This steady electrical supply is subject to minimal variations-variations that are imperceptible to the consumer and do not normally harm electrical devices. An overload current is any surge that exceeds the variances of this normal operating current. The higher the overcurrent, the more potential it has to damage electrical devices. One of the most important principles of overcurrent protection, therefore, is that the higher the magnitude of the overload current, the faster the overcurrent must be interrupted.



How do overcurrents occur? Most overcurrents are temporary and harmless, caused when motors start up or transformers are energised. Such things as defective motors, overloaded equipment or too many loads on one circuit, however, can cause harmful, sustained overcurrents, which must be shut off quickly to avoid damaging the entire distribution system. An inadequately protected system can cause damage ranging from electrical shocks to people coming in contact with electrical equipment, to fires caused by the thermal ignition of electrical materials on the overloaded circuit.

Electrical storms and lightning are among the biggest causes of major distribution overcurrent worldwide. In the United States alone, 67 people are killed every year by these types of storms (including those killed by falling trees and power lines-not only surges). The intense current of a lightning discharge creates a fleeting, but very strong, magnetic field. A single lightning strike can produce up to a billion volts of electricity. If lightning strikes a house, it can easily destroy all the electrical equipment inside, and damage the distribution system to which that house is connected.

To protect people and devices adequately, overcurrent protection needs to be sensitive, selective, fast and reliable. In the interest of conservation, most power systems generate different loads at different times of the day; overcurrent protection must therefore be sensitive enough to operate under conditions of both minimum and maximum power generation. It also needs to be selective so that it can differentiate between conditions that require immediate action and those where limited action is required; in other words, it should shut down the minimum number of devices to avoid disrupting the rest of the electrical system. Overcurrent protection also needs to be fast; it should be able to quickly disconnect undamaged equipment from the area of overcurrent and thus prevent the spread of the fault. Of course, the most basic requirement of protective equipment is that it is reliable, performing correctly wherever and whenever it is needed.

When an overcurrent occurs at a major electricity supply point such as a power station, the resulting surge, if it is not checked, can damage the entire distribution system. Like a flooding river-which breaks its banks and floods smaller rivers, which in turn flood streets and houses - the extra voltage courses through the network of wires and devices that comprise the distribution system, until it discharges its excessive energy into the earth. This is why each piece of equipment within the electricity manufacturing and distribution system must be protected by a grounding or earthing mechanism-the grounding mechanism allows the excess electricity to be discharged into the earth directly, instead of passing it further down the distribution system.

Within the distribution system, surge protection is provided by overcurrent relays. Relays are simply switches that open and close under the control of another electrical circuit; an overcurrent relay is a specific type of relay that operates only when the voltage on a power line exceeds a predetermined level. If the source of an overcurrent is nearby, the overcurrent relay shuts off instantaneously. One danger, however, is that when one electrical circuit shuts down, the electricity may be rerouted through adjacent circuits, causing them to become overloaded. At its most extreme, this can lead to the 'blackout' of an entire electrical network. To protect against this, overcurrent relays have a time-delay response; when the source of an overcurrent is far away, the overcurrent relays delay slightly before shutting down-thereby allowing some of the current through to the next circuit, so that no single circuit becomes overloaded. An additional benefit of this system is that when power surges do occur, engineers are able to use these time delay sequences to calculate the source of the fault.

Fuses and circuit breakers are the normal overcurrent protection devices found in private homes. Both devices operate similarly: they allow the passage of normal currents, but quickly 'trip', or interrupt, when too much current flows through. Fuses and circuit breakers are normally located in the home's electrical switch box-which takes the main power coming into the house and distributes it to various parts of the home. Beyond this level of home protection, it is also advisable to purchase additional 'tripping' devices for sensitive electrical devices such as computers, telephones and modems. While many electrical devices are equipped with internal

surge protection, the value of these devices usually warrants additional protection such as may be gained from purchasing an additional protective device.

The modern world could not exist without reliable electricity generation and distribution. While overcurrents cannot be entirely avoided, it is possible to mitigate their effects by providing adequate protection at every level of the electrical system, from the main power generation stations to the individual home devices we all rely upon in our daily lives.

#### **Questions 28 - 33**

Choose the correct letter, A, B, C or D. Write your answers in boxes 28-33 on your answer sheet.

28. In a normal electrical system,
- voltage differences are usually quite small.
  - overcurrent protection is mainly provided by circuit breakers and fuses.
  - different amounts of electricity are generated at different times of day.
  - some circuits constantly experience a certain level of overcurrent.
29. The writer suggests that most overcurrents.
- are harmless and temporary.
  - affect all levels of the distribution system.
  - are triggered by electrical storms.
  - can be instantaneously controlled by relays.
30. What does the writer state is the most basic requirement of overcurrent protection equipment?
- Speed
  - Selectivity
  - Sensitivity
  - Reliability
31. The writer suggests that most household electrical devices
- are adequately protected by the home's electrical switch box.
  - should be protected from overcurrent by additional devices.
  - produce strong magnetic fields that can sometimes cause surges.
  - are designed to shut off after a short time delay.
32. In which of the following circumstances might the shut-down of an overcurrent relay be delayed?
- If the source of an overcurrent is nearby
  - If an overcurrent is caused by an electrical storm
  - If an entire electrical network experiences 'blackout'
  - If the source of an overcurrent is far away
33. What is an essential safety requirement for every device in an electrical system?
- A grounding mechanism
  - The ability to shut down quickly
  - Sensitivity to variances in the electrical system
  - Internal surge protection

#### **Questions 34 - 40**

Do the following statements agree with the information given in Reading Passage 3? In boxes 34-40 on your answer sheet, write

TRUE	if the statement agrees with the information
FALSE	if the statement contradicts the information
NOT GIVEN	if there is no information on this

- Effective overcurrent protection systems shut down as few devices as possible.
- Electricians must use special tools to fit fuses.
- The most common cause of overcurrents is the presence of too many loads on one circuit.
- Overcurrents course through the entire distribution system unless they are discharged into the earth.
- Over one hundred people are killed by electrical storms worldwide each year.
- The effects of overcurrents are magnified when electricity comes in contact with water.
- All variations in electrical voltage are potentially damaging, and must be prevented.

**Reading 8****High Impact Reading****READING PASSAGE 1****A very brief history of time**

These days, time is everything. We worry about being late, we rush to get things done or to be somewhere and our daily schedules are often planned down to the minute. Of course, none of this would have been possible without the humble clock. The internationally accepted division of time into regular, predictable units has become an essential aspect of almost all modern societies yet the history of time keeping is almost as old as civilisation itself. Nearly 3000 years ago, societies were using the stars in order to keep track of time to indicate agricultural cycles. Then came the sundial, an Egyptian invention in which the shadow cast by the sun was used to measure the time not of the seasons but of the day.

The first manufactured clock, believed to have come from Persia, was a system which recreated the movements of the stars. All the celestial bodies which had been used to tell the time of year were plotted onto an intricate system in which the planets rotated around each other. Not being dependent on either sunlight or a clear night, this was one of the earliest systems to divide a complete day. Although ingenious for its time, this method suffered from incorrect astrological assumptions of the period in which it was believed that the Earth was the centre of the universe.

The Greeks were next to develop a more accurate clock using water to power a mechanism that counted out the divisions of the day. The simplest water clock consisted of a large urn that had a small hole located near the base and a graduated stick attached to a floating base. The hole would be plugged while the urn was being filled with water, and then the stick would be inserted into the urn. The stick would float perpendicular to the surface of the water, and when the hole at the base of the urn was unplugged the passage of time was measured as the stick descended farther into the urn.

Then, for nearly one thousand years, there was little in the way of progress in time keeping until the European invention of spring-powered clocks in the late fourteenth century. Unreliable and inaccurate, the early models of these clocks were useful in that they gave direction to new advances. In 1656 Christiaan Huygens, a Dutch scientist, made the first pendulum clock, which had an error of less than one minute a day, the first time such accuracy had been achieved. His later refinements reduced his clock's error to less than 10 seconds a day. Some years later, Huygens abandoned the pendulum for a balance wheel and spring assembly which allowed for a whole new generation of time piece - the wristwatch. Still found in some of today's wrist watches, this improvement allowed portable seventeenth-century watches to keep time to 10 minutes a day.

While clock making and musical chime clocks became increasingly popular, it was the invention of the cuckoo clock, designed and made by Franz Anton Ketterer, which really caught people's imagination. The design was not particularly complex. The clock was mounted on a headboard, normally a very elaborate carving reflecting the tastes of the artist. Many of the original cuckoo clocks are still kept today because of the artwork on the headboard. Using the traditional circular pendulum design, the clock could run accurately {or up to a week, using a weight to keep the pendulum in motion. Again, the weight was often carved with a design making it as much an art form as a timepiece. The most innovative feature of these cuckoo clocks, as the name implies, is that a small carved cuckoo came out of the clock to chime the hour. Particularly ingenious was the placement of bellows inside the clock, which were designed to recreate the sound made by the bird, although later models included a lever on the bottom of the clock which could be used to stop this hourly chime.

Refinements to this original pendulum concept meant that by 1721 the pendulum clock remained accurate to within one second per day by compensating for changes in the pendulum's length due to temperature variations. Over the next century, further refinements reduced this to a hundredth of a second a day. In the 1920s, a new era of clock making began which is still popular today - the quartz clock. When under pressure, quartz generates an electric field of relatively constant frequency, and it was discovered that this electric signal was sufficient to power a clock. Quartz crystal clocks were better because they had fewer moving parts to disturb their regular frequency. Even so, they still rely on a mechanical vibration and this depends on the size of the crystal, and as no two crystals can be exactly alike, there is a degree of difference in every quartz watch.

Comparing performance to price, it is understandable that quartz clocks still dominate the market. Yet they are no longer the most accurate. Scientists had long realised that each chemical element in the universe absorbs and emits electromagnetic radiation at its own specific frequencies. These resonances are inherently stable, thus forming the basis for a reliable system of time measurement, all the more so because no moving parts are needed to record these resonances. Yet the cost of these atomic clocks mean that such timekeeping precision is a long way from becoming common.

**Questions 1-8**

Match a type of clock with a description.

1. Quartz clock
2. Cuckoo clock
3. Sundial
4. Persian clock
5. Wristwatch
6. Pendulum
7. Atomic clock
8. Water clock

- A. Relied on basic scientific principles
- B. was the first to replace the pendulum
- C. Is the most common method of timekeeping
- D. Is the most accurate clock
- E. Is the earliest known method of measuring time during the day
- F. Was inaccurate because of misconceptions of the age
- G. Was often highly ornamental
- H. Had only a 10-second margin of error per day

**Questions 9-12**

Label the diagram using words from the text.

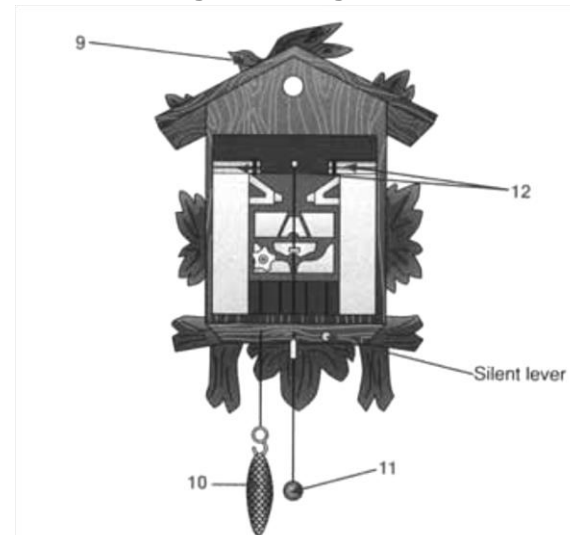

**Questions 13-15**

Complete the following summary using NO MORE THAN TWO WORDS.

Although quartz clocks are 13....., the atomic clock is the most 14..... as it does not rely on any 15.....

## READING PASSAGE 2

**Holiday blues**

*The holiday season has always been a cause for celebration around the world. The opportunity to take a break from work, be frivolous, go on holiday, meet family and friends - all good reasons to look forward to the holidays with enthusiasm and anticipation. Or at least that is what we are led to believe.*

- A. Research carried out in America suggests that these feelings of euphoria may be somewhat misplaced. A study recently carried out by New York University Child Study Centre has concluded that one in three people of varying ages suffer 'holiday blues' to varying extents, from a mild feeling of sadness to severe, sometimes even suicidal, depression. The effects can manifest themselves in many ways, such as an inability to sleep or sleeping too much, overeating or under eating, headaches or drinking too much. The report also concluded that not only are there a number of complex causes that can trigger such depression (psychological and biological), there are an equal number of opinions as to the best solution.
- B. According to Dr Frank Pittman, a leading family psychiatrist, the most significant cause for holiday depression actually stems from our concerns about our family. During the holiday season, families meet, often for the first time since the last holiday season, and try to make these reunions 'perfect'. In fact, says Pittman, we count on the holidays to compensate for the rest of the year: He himself comments that 'I wanted to make up to the family for not having been a good enough father and uncle all year'. However, such good intentions are often thwarted by old family arguments, feelings of not being appreciated or being used, all of which result in holiday stress. It seems that the idyllic picture of our family we wish to build in our minds cannot be sustained in reality.
- C. Although Pittman holds family to be the source of much of the problem, others point to a more general social context. Gift shopping, for example, does not help reduce tensions - crowded shops, long queues, the pressure of choosing just the right present — all of these things contribute to a feeling of stress and anxiety. On the other end of the scale, there are those without family who experience a sense of extreme loneliness and isolation throughout this period, often spending the long holidays alone. Any feelings of inadequacy they may harbour throughout the year can often become unbearable at a time when friends are unavailable and enjoying an apparently cozy break with their loved ones. In fact, such is the extreme nature of this isolation that many organisations have been established to offer some help and support in those who feel most alone over what should be the 'festive' season.
- D. Others, however, argue that more scientific explanations carry an equal weight in explaining holiday blues. Seasonal Affective Disorder, or SAD as it is more commonly known, is also held responsible for winter depression. A natural reaction to falling levels of sunlight, the pineal gland secretes the hormone melatonin, which has the effect of slowing the body down. When days get shorter, more of the hormone is released causing sufferers to become lethargic and miserable. From being industrious people with plenty of energy, SAD sufferers find themselves increasingly weary and unable to sustain any prolonged activity, a situation which often leads to depression. In addition, for many people this has a major impact not only on their personal life but also on their professional life, as employers often see this lack of productivity in terms of laziness or unwillingness to work. As a result, SAD has been linked directly to the high rate of suicide in a number of Scandinavian countries during winter months, when there are often a few hours of sunlight a day.
- E. The good news for SAD sufferers is that there is a cure, and as far as many medical cures go this is relatively simple. As the cause is lack of bright light, the treatment is to

be in bright light every day. This can obviously be achieved by staying in a brightly lit climate, explaining why skiing holidays are so popular as they allow people to get plenty of sunlight as well as providing a stimulating activity. Another method is by using light therapy, in which patients sit in front of a lamp which acts in the same way as sunlight. To be more specific, the light should be about as bright as early morning sunshine, and the user should allow the light to reach the eyes for anything up to one hour a day in order to alleviate the symptoms. There are a number of companies currently manufacturing these lights as a health aid and they are even being prescribed by some doctors. In addition, they can be bought at considerably less than the cost of a holiday.

Whatever fundamental reason underpins holiday depression, it seems reasonable to argue that the phenomenon does indeed exist. Voluntary support services, offering counseling services to those who need the unbiased and friendly voice of a stranger to help them work through their unhappiness, report a significant increased demand for their services during holiday periods such as Christmas and the New Year.

**Questions 16-17                      Circle the correct answer A-C.**

16. Research has shown that
- A. we become more depressed during the holidays
  - B. poor diet can lead to depression
  - C. simple things can lead us to feel varying degrees of depression.
17. Dr Pittman believes holiday depression comes from
- A. feelings of inadequacy
  - B. being alone
  - C. over-compensation.

**Questions 18-21**

Answer the following questions using **NO MORE THAN THREE WORDS.**

18. What is the chemical cause for lethargy in SAD sufferers?  
 19. Why is the Scandinavian suicide rate so high in winter?  
 20. What daily treatment can SAD sufferers benefit from?  
 21. For whom are the holiday periods the busiest time?

**Questions 22-26**

Choose the most suitable headings for sections A-E from the list below. Use each heading once only.

- i. Family cures
- ii. Addressing the problem
- iii. Impact of personality
- iv. Psychological factors
- v. Biological factors
- vi. Avoiding stress
- vii. Manifestations of depression
- viii. Depression in children
- ix. Pressures of the holiday period

- |  |
|--|
| <p>22. Section A<br/>         23. Section B<br/>         24. Section C<br/>         25. Section D<br/>         26. Section E</p> |
|--|

## READING PASSAGE 3

**Weakness of the school system**

- A. By attempting to fit in as much as possible, the school day is continually being added to. In many ways, this would appear to be a good idea, as our knowledge and understanding of the world is always growing and it would seem logical to incorporate this into schools. The reality, however, has some decided drawbacks. There is a growing feeling amongst many that the modern school curriculum, in an effort to teach as many varied subjects as possible, is actually teaching students less. It seems that by constantly adding to what should be taught in the classroom, the classes are less focused, not offering the deeper learning that institutions perhaps should.
- B. With classes sometimes only 30 minutes long, the overwhelming amount of information teachers are required to present often only gives students time to learn facts, not to think in any great detail about what they are being presented with. The problem is that students are not getting the opportunity to absorb what they are being taught as the curriculum expands in order to keep what has already been taught and supplement it with everything new that comes along. The weaknesses of such a system are clear — well informed though such students may be, there is the risk of an increasing number of graduates who have no real creative or intellectual ability. By denying students the opportunity to sit and think their way through problems, or even consider their own opinion, some schools are not always providing a truly educational atmosphere. There are, of course, certain aspects of education which need to be taught by simply inputting the information. Basic mathematics, for example. But there are many other subjects, which could be best learned by having an opportunity to think and discuss what is being taught. Literature, writing and the social sciences are good examples of subjects which cannot be considered as ‘covered’ by a mass of information without the opportunity to discuss, debate or consider meaning or implications. There are also important social skills to be learned during such periods of open discussion, skills which are not addressed by an endless flow of teacher- centred information.
- C. Teachers themselves have also voiced concerns about the amount of information they are required to impress upon their students. There is a feeling in many educational establishments that students are no longer being educated, but taught how to pass tests. In a world where academic success is too often measured by examination results, this is a serious concern. If there is too much information to simply be memorised and not enough time to truly assimilate it, what happens to students who fail to meet the grade? By current standards, they are failures, yet they may have great potential in areas not covered by the test and there are many students who, despite clear intellectual ability, simply do not perform well in tests. Again, the problem is one of focus, as education authorities are looking at the outcome of schooling rather than the content presented in the class.
- D. It is here that many teachers feel the situation could be addressed at a local level. By giving more discretion to teachers, school courses could be tailored to suit the students rather than tailoring students to meet ever-expanding course requirements. In addition, by running a curriculum that gives options rather than defines an entire course, considerably more freedom would be possible. As it is, progression through most primary and secondary schools is regimented, and there is little room for students to identify and develop their own skills and strengths. If material could be chosen on the basis of its merits rather than simply because it has been put in the curriculum, then what is selected may be taught to a depth that would serve some purpose. There is, of course, a counter-argument, which claims that such open guidelines could lead to vast differences in standards between schools. What one teacher may see as essential for a student’s education, another may see as irrelevant, and this will result in students with widely different educational strengths.
- E. With such a high-pressure learning environment, there are also a number of social aspects to schooling which need to be considered. The increased student workload cannot be covered in the classroom alone for the simple reason that there is not enough time in the average

school week, and much of this extra workload has been pushed into the realm of homework. At its best, homework should be the opportunity to look in greater detail at what has been studied. In other words, to actually think about it and its relevance. The reality, however, is often very different. Concerned parents and overextended students are finding that homework is taking an increasingly large part of a student's evening, cutting into time many feel should be spent as part of a child's social education. Other social pressures have compounded the situation, as many of the areas of educating a young child which should be the responsibility of the parents have ill-advisedly become the school's responsibility. Drug awareness and health issues, for example, are occupying an increasingly large part of the school day.

- F. Many people believe that we should be teaching less, but teaching it better, and it is here that they think a solution can be found. Yet the process of rewriting a curriculum to incorporate only that which is essential but can be well learned would take far longer than most educational authorities have, and would be considered by many to be a 'regressive' step. Changes in the curriculum have largely been motivated by changes in the nature of employment, as job mobility demands that people know something about considerably more areas than were traditionally necessary. A little about a lot allows for the job mobility which has become so common. No matter what the final verdict may be, one thing is for sure - change will be slow and not always for the best.

**Questions 27-32**

Choose the most suitable headings for sections A-F from the list below. Use each heading once only

- i. A question or time
- ii. Lack of teacher training
- iii. Student success
- iv. The argument for flexibility
- v. Importance of teaching experience
- vi. Extra-curricular pressures
- vii. The benefits of a varied curriculum
- viii. Imbalanced focus
- ix. Overreliance on examinations
- x. Quality or quantity?

- 27. Section A
- 28. Section B
- 29. Section C
- 30. Section D
- 31. Section E
- 32. Section F

**Questions 33-37**

Do the following statements agree with the views of the writer? Write

- YES                                    If the statement agrees with the writer  
 NO                                        if the statement does not agree with the writer  
 NOT GIVEN                            if there is no information about this in the passage.

- 33. Classes are often too short.
- 34. No subjects can be comprehensively learned without time to discuss and debate the facts.
- 35. Tests are a fair measure of ability,
- 36. Schools are trying to be responsible for too many aspects of a child's education.
- 37. Future changes in the curriculum will improve the situation.

**Questions 38-40**

Complete the summary below using NO MORE THAN TWO WORDS from the text.

Too much emphasis is placed on learning 38..... The modern school curriculum is largely a response to increased 39..... for which graduates are expected to have a much broader general knowledge. One potential solution to this could be to give individual schools 40.....regarding what is taught.



## Reading 9

**Official materials new**

## READING PASSAGE 1

Questions 1- 6

Reading Passage 1 has six paragraphs, A-F. Choose the correct heading for each paragraph from the list of headings below. Write the correct number i-ix, in boxes 1-6 on your answer sheet.

List of Headings

- i. The appearance and location of different seaweeds
- ii. The nutritional value of seaweeds
- iii. How seaweeds reproduce and grow
- iv. How to make agar from seaweeds
- v. The under-use or native seaweeds
- vi. Seaweed species at risk of extinction
- vii. Recipes for how to cook seaweeds
- viii. The range of seaweed products
- ix. Why seaweeds don't sink or dry out

- |                |
|----------------|
| 1. Paragraph A |
| 2. Paragraph B |
| 3. Paragraph C |
| 4. Paragraph D |
| 5. Paragraph E |
| 6. Paragraph F |

**Seaweeds of New Zealand**

- A. Seaweed is a particularly wholesome food, which absorbs and concentrates traces of a wide variety of minerals necessary to the body's health. Many elements may occur in seaweed - aluminum, barium, calcium, chlorine, copper, iodine and iron, to name but a few — traces normally produced by erosion and carried to the seaweed beds by river and sea currents. Seaweeds are also rich in vitamins; indeed, Inuits obtain a high proportion of their bodily requirements of vitamin C from the seaweeds they eat. The health benefits of seaweed have long been recognised. For instance, there is a remarkably low incidence of goitre among the Japanese, and also among New Zealand's indigenous Maori people, who have always eaten seaweeds, and this may well be attributed to the high iodine content of this food. Research into historical Maori eating customs shows that jellies were made using seaweeds, nuts, fuchsia and tutu berries, cape gooseberries, and many other fruits both native to New Zealand and sown there from seeds brought by settlers and explorers. As with any plant life, some seaweeds are more palatable than others, but in a survival situation, most seaweeds could be chewed to provide a certain sustenance.
- B. New Zealand lays claim to approximately 700 species of seaweed, some of which have no representation outside that country. Of several species grown worldwide, New Zealand also has a particularly large share. For example, it is estimated that New Zealand has some 30 species of Gigartina, a close relative of carrageen or Irish moss. These are often referred to as the New Zealand carrageens. The substance called agar which can be extracted from these species gives them great commercial application in the production of seameal, from which seameal custard (a food product) is made, and in the canning, paint and leather industries. Agar is also used in the manufacture of cough mixtures, cosmetics, confectionery and toothpastes. In fact, during World War II, New Zealand Gigartina were sent to Australia to be used in toothpaste.
- C. New Zealand has many of the commercially profitable red seaweeds, several species of which are a source of agar (Pterocladia, Gelidium, Chondrus, Gigartina). Despite this, these seaweeds were not much utilised until several decades ago. Although distribution of the Gigartina is confined to certain areas according to species, it is only on the east coast of the North Island that its occurrence is rare. And even then, the east coast, and the area around Hokianga, have a considerable supply of the two species of Pterocladia from which agar is also made. New Zealand used to import the Northern Hemisphere Irish moss (Chondrus crispus) from England and ready-made agar from Japan.
- D. Seaweeds are divided into three classes determined by colour — red, brown and green — and each tends to live in a specific position. However, except for the unmistakable sea lettuce (Ulva), few are totally one colour; and especially when dry, some species can

change colour significantly — a brown one may turn quite black, or a red one appear black, brown, pink or purple. Identification is nevertheless facilitated by the fact that the factors which determine where a seaweed will grow are quite precise, and they tend therefore to occur in very well-defined zones. Although there are exceptions, the green seaweeds are mainly shallow-water algae; the browns belong to the medium depths; and the reds are plants of the deeper water, furthest from the shore. Those shallow-water species able to resist long periods of exposure to sun and air are usually found on the upper shore, while those less able to withstand such exposure occur nearer to, or below, the low-water mark. Radiation from the sun, the temperature level, and the length of time immersed also play a part in the zoning of seaweeds. Flat rock surfaces near mid-level tides are the most usual habitat of sea-bombs, Venus' necklace, and most brown seaweeds. This is also the home of the purple laver or Maori karengo, which looks rather like a reddish-purple lettuce. Deep-water rocks on open coasts, exposed only at very low tide, are usually the site of bull-kelp, strapweeds and similar tough specimens. Kelp, or bladder kelp, has stems that rise to the surface from massive bases or 'holdfasts', the leafy branches and long ribbons of leaves surging with the swells beyond the line of shallow coastal breakers or covering vast areas of calmer coastal water.

- E. Propagation of seaweeds occurs by seed-like spores, or by fertilisation of egg cells. None have roots in the usual sense; few have leaves; and none have flowers, fruits or seeds. The plants absorb their nourishment through their leafy fronds when they are surrounded by water; the holdfast of seaweeds is purely an attaching organ, not an absorbing one.
- F. Some of the large seaweeds stay on the surface of the water by means of air-filled floats; others, such as bull-kelp, have large cells filled with air. Some which spend a good part of their time exposed to the air, often reduce dehydration either by having swollen stems that contain water, or they may (like Venus' necklace) have swollen nodules, or they may have a distinctive shape like a sea-bomb. Others, like the sea cactus, are filled with a slimy fluid or have a coating of mucilage on the surface. In some of the larger kelps, this coating is not only to keep the plant moist, but also to protect it from the violent action of waves.

**Questions 7 - 10**

Complete the flow chart below. Choose NO MORE THAN THREE WORDS from the passage for each answer. Write your answers in boxes 7-10 on your answer sheet.

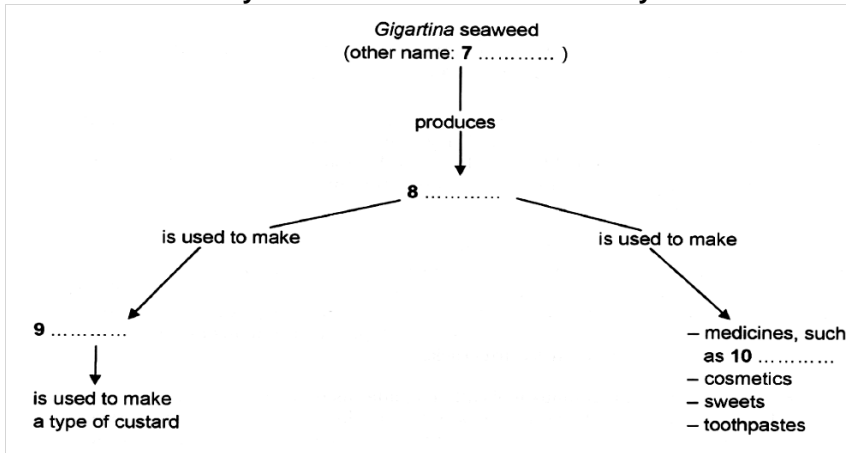

**Questions 11 — 13**

Classify the following characteristics as belonging to

- A. brown seaweed
- B. green seaweed
- C. red seaweed

Write the correct letter, A, B or C, in boxes 11- 13 on your answer sheet.

- 11. can survive the heat and dryness at the high-water mark
- 12 grow far out in the open sea
- 13 share their site with karengo seaweed

## READING PASSAGE 2

**TWO WINGS AND A TOOLKIT**

*A research team at Oxford University discover the remarkable tool-making skills of New Caledonian crows*

Betty and her mate Abel are captive crows in the care of Alex Kacelnik, an expert in animal behaviour in Oxford University. They belong to a forest-dwelling species of bird (*Corvus moneduloides*) confined to two islands in the South Pacific. New Caledonian crows are tenacious predators, and the only birds that habitually use a wide selection of self-made tools to find food.

One of the wild crow's cleverest tools is the crochet hook, (made by detaching a side twig from a larger one, leaving enough of the larger twig to shape into a hook. Equally cunning is a tool crafted from the barbed vine leaf, which consists of a central rib with paired leaflets each with a rose-like thorn at its base. They strip out a piece of this rib, removing the leaflets and all but one thorn at the top, which remains as a ready-made hook to prize out insects from awkward cracks.

The crows also make an ingenious tool called a padanus probe from padanus tree leaves. The tool has a broad base, sharp tip, a row of tiny hooks along one edge, and a tapered shape created by the crow nipping and tearing to form a progression of three or four steps along the other edge of the leaf. What makes this tool special is that they manufacture it to its standard design, as if following a set of instructions. Although it is rare to catch a crow in the act of clipping out a padanus probe, we do have ample proof of their workmanship: the discarded leaves from which the tools are cut. The remarkable thing that these 'counterpart' leaves tell us is that crows consistently produce the same design every time, with no in-between or trial versions. It's left the researchers wondering whether, like people, they envisage the tool before they start and perform the actions they know are needed to make it. Research has revealed that genetics plays a part in the less sophisticated tool-making skills of finches in the Bushes in the Galapagos islands. No one knows if that's also the case for New Caledonian crows, but it's highly unlikely that their tool-making skills are hardwired into the brain. 'The picture so far points to a combination of cultural transmission — from parent birds to their young - and individual resourcefulness,' says Kacelnik.

In a test at Oxford, Kacelnik's team offered Betty and Abel an original challenge — food in a bucket at the bottom of a well. The only way to get the food was to hook the bucket out by its handle. Given a choice of tools — a straight length of wire and one with hooked end - the birds immediately picked the hook showing that they did indeed understand the functional properties of the tool.

But do they also have the foresight and creativity to plan the construction of their tools? It appears they do. In one bucket-in-the-well test, Abel carried off the hook, leaving Betty with nothing but the straight wire. 'What happened next was absolutely amazing says Kacelnik. She wedged the tip of the wire into a crack in a plastic dish and pulled the other end to fashion her own hook. Wild crows don't have access to pliable, bendable material that retains its shape, and Betty's only similar experience was a brief encounter with some pipe cleaners a year earlier. In nine out of ten further tests, she again made hooks and retrieved the bucket.

The question of what's going on in a crow's mind will take time and a lot more experiments to answer, but there could lie a lesson in it for understanding our own evolution. Maybe our ancestors, who suddenly began to create symmetrical tools with carefully worked edges some 1.5 million years ago. didn't actually have the sophisticated mental abilities with which

we credit them. Closer scrutiny of the brains of New Caledonian crows might provide a few pointers to the special attributes they would have needed. 'If we're lucky we may find specific developments in the brain that set these animals apart', says Kacelnik.

One of these might be a very strong degree of laterality — the specialization of one side of the brain to perform specific tasks. In people, the left side of the brain controls the processing of complex sequential tasks, and also language and speech. One of the consequences of this is thought to be right-handedness. Interestingly, biologists have noticed that most padanus probes are cut from the left side of the leaf meaning that the birds clip them with the right side of their beaks — the crow equivalent of right handedness. The team thinks this reflects the fact that the left side of the crow's brain is specialised to handle the sequential processing required to make complex tools. Under what conditions might this extraordinary talent have emerged in these two species? They are both social creatures, and wide-ranging in their feeding habits. These factors were probably important but, ironically, it may have been their shortcomings that triggered the evolution of tool-making. Maybe the ancestors of crows and humans found themselves in a position where they couldn't make the physical adaptations required for survival — so they had to change their behaviour instead. The stage was then set for the evolution of those rare cognitive skills that produce sophisticated tools. New Caledonian crows may tell us what those crucial skills are.

**Questions 14 - 17**

Label the diagrams below. Choose NO MORE THAN TWO WORDS from the passage for each answer

**THREE TOOLS MADE BY CROWS**

a. 14.....

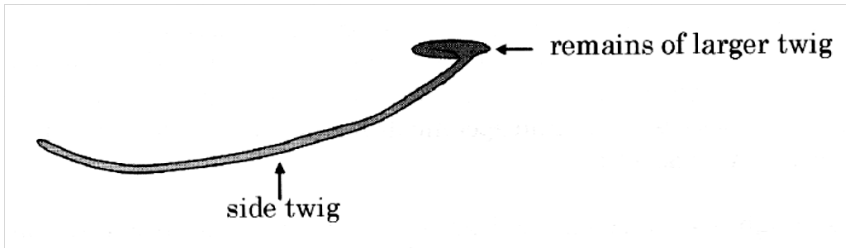

**b) Barbed vine-leaf stick**

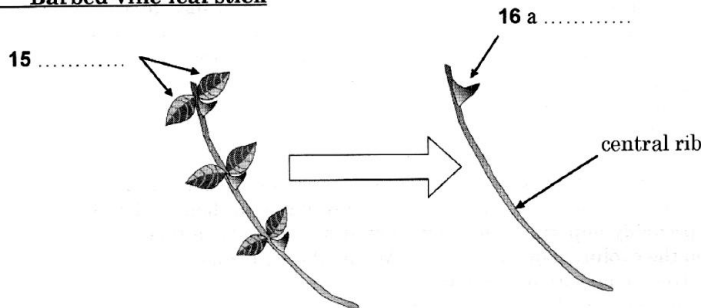

**c) Padanus probe**

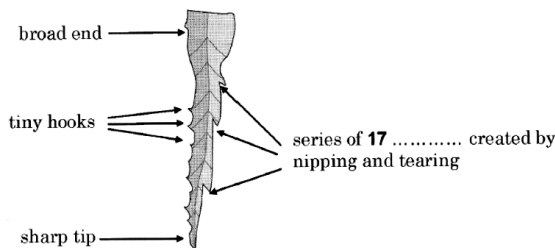

**Questions 18 - 23**

Do the following statements agree with the information given in Reading Passage 2? Write

TRUE if the statement agrees with the information

FALSE if the statement contradicts the information

NOT GIVEN if there is no information on this

18. There appears to be a fixed pattern for the padanus probe's construction.
19. There is plenty of evidence to indicate how the crows manufacture the padanus probe.
20. Crows seem to practise a number of times before making a usable padanus probe.
21. The researchers suspect the crows have a mental image of the padanus probe before they create it.
22. Research into how the padanus probe is made has helped to explain the tool-making skills of many other bird species.
23. The researchers believe the ability to make the padanus probe is passed down to the crows in their genes.

**Questions 24 - 26**

Choose THREE letters, A-G.

According to the information in the passage, which THREE of the following features are probably common to both New Caledonian crows and human beings?

- A. keeping the same mate for life
- B. having few natural predators
- C. having a bias to the right when working
- D. being able to process sequential tasks
- E. living in extended family groups
- F. eating a variety of foodstuffs
- G. being able to adapt to diverse habitats

**READING PASSAGE 3****How did writing begin?****Many theories few answers**

The Sumerians, an ancient people of the Middle East, had a story explaining the invention of writing more than 5,000 years ago. It seems a messenger of the King of Uruk arrived at the court of a distant ruler so exhausted that he was unable to deliver the oral message. So the king set down the words of his next messages on a clay tablet. A charming story, whose retelling at a recent symposium at the University of Pennsylvania amused scholars. They smiled at the absurdity of a letter which the recipient would not have been able to read. They also doubted that the earliest writing was a direct rendering of speech. Writing more likely began as a separate, symbolic system of communication and only later merged with spoken language.

Yet in the story the Sumerians, who lived in Mesopotamia, in what is now southern Iraq, seemed to understand writing's transforming function. As Dr Holly Pittman, director of the University's Center for Ancient Studies, observed, writing 'arose out of the need to store and transmit information over time and space'.

In exchanging interpretations and information, the scholars acknowledged that they still had no fully satisfying answers to the questions of how and why writing developed. Many favoured an explanation of writings origins in the visual arts, pictures becoming increasingly abstract and eventually representing spoken words. Their views clashed with a widely held theory among archaeologists that writing developed from the pieces of clay that Sumerian accountants used as tokens to keep track of goods.

Archaeologists generally concede that they have no definitive answer to the question of whether writing was invented only once, or arose independently in several places, such as Egypt, the Indus Valley, China, Mexico and Central America. The preponderance of

archaeological data shows that the urbanizing Sumerians were the first to develop writing, in 3,200 or 3,300 BC. These are the dates for many clay tablets in an early form of cuneiform, a script written by pressing the end of a sharpened stick into wet clay, found at the site of the ancient city of Uruk. The baked clay tablets bore such images as pictorial symbols of the names of people, places and things connected with government and commerce. The Sumerian script gradually evolved from the pictorial to the abstract, but did not at first represent recorded spoken language.

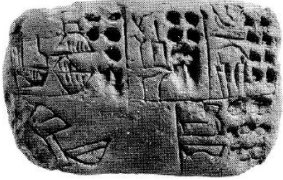

### Cuneiform Writing

Dr Peter Damerow, a specialist in Sumerian cuneiform at the Max Planck Institute for the History of Science in Berlin, said, 'It is likely that there were mutual influences of writing systems around the world. However, their great variety now shows that the development of writing, once initiated, attains a considerable degree of independence and flexibility to adapt to specific characteristics of the sounds of the language to be represented.' Not that he accepts the conventional view that writing started as a representation of words by pictures. New studies of early Sumerian writing, he said, challenge this interpretation. The structures of this earliest writing did not, for example, match the structure of spoken language, dealing mainly in lists and categories rather than in sentences and narrative.

For at least two decades, Dr Denise Schmandt-Besserat, a University of Texas archaeologist, has argued that the first writing grew directly out of a system practised by Sumerian accountants. They used clay tokens, each one shaped to represent a jar of oil, a container of grain or a particular kind of livestock. These tokens were sealed inside clay spheres, and then the number and type of tokens inside was recorded on the outside using impressions resembling the tokens. Eventually, the token impressions were replaced with inscribed signs, and writing had been invented.

Though Dr Schmandt-Besserat has won much support, some linguists question her thesis, and others, like Dr Pittman, think it too narrow. They emphasise that pictorial representation and writing evolved together. 'There's no question that the token system is a forerunner of writing' Dr Pittman said, 'but I have an argument with her evidence for a link between tokens and signs, and she doesn't open up the process to include picture making.'

Dr Schmandt Besserat vigorously defended her ideas. 'My colleagues say that pictures were the beginning of writing,' she said, 'but show me a single picture that becomes a sign in writing. They say that designs on pottery were the beginning of writing, but show me a single sign of writing you can trace back to a pot — it doesn't exist'. In its first 500 years, she asserted, cuneiform writing was used almost solely for recording economic information, and after that its uses multiplied and broadened.

Yet other scholars have advanced different ideas Dr Piotr Michalowski, Professor of Near East Civilizations at the University of Michigan, said that the proto—writing of Sumerian Uruk was 'so radically different as to be a complete break with the past'. It no doubt served, he said, to store and communicate information, but also became a new instrument of power. Some scholars noted that the origins of writing may not always have been in economics. In Egypt, most early writing is high on monuments or deep in tombs. In this case, said Dr Pascal Vernus from a university in Paris, early writing was less administrative than sacred. It seems that the only certainty in this field is that many questions remain to be answered.

**Questions 27 – 30**

Choose the correct tartan A, B, C or D.

27. The researchers at the symposium regarded the story of the King of Uruk as ridiculous because
- writing probably developed independently of speech.
  - clay tablets had not been invented at that time.
  - the distant ruler would have spoken another language.
  - evidence of writing has been discovered from an earlier period.
28. According to the writer, the story of the King of Uruk
- is e probable explanation of the origins of writing.
  - proves that early writing had a different function to writing today.
  - provides an example of symbolic writing.
  - shows some awareness amongst Sumerians on the purpose of writing.
29. There was disagreement among the researchers at the symposium about
- the area where writing began.
  - the nature of early writing materials.
  - the way writing began.
  - the meaning of certain abstract images.
30. The opponents of the theory that writing developed from tokens believe that it
- grew out of accountancy.
  - evolved from pictures.
  - was initially intended as decoration.
  - was unlikely to have been connected with commerce.

**Questions 31-36**

Look at the following statements (Questions 31-36) and the list of people below.

Match each statement with the correct person, A-E.

Write the correct letter, A-E, in boxes 31-36 on your answer sheet.

NB You may use any letter more than once.

- There is no proof that early writing is connected to decorate household objects.
- As writing developed, it came to represent speech.
- Sumerian writing developed into a means of political control.
- Early writing did not represent the grammatical features of speech.
- There is no convincing proof that tokens and signs are connected.
- The uses of cuneiform writing were narrow at first, and later widened.

**List of People**

- Dr Holly Pittman
- Dr Peter Damerow
- Dr Denise Schmandt-Besserat
- Dr Piotr Michalowski
- Dr Pascal Vernus

**Questions 37- 40**

Complete the summary using the list of words, A-N, below.

The earliest form of writing

Most archaeological evidence shows that the people of 37 .....invented writing in around 3,300 BC. Their script was written on 38 .....and was called 39 ..... . Their script originally showed images related to political power and business, and later developed to become more 40 . . .

- |                 |                |               |                   |               |                 |
|-----------------|----------------|---------------|-------------------|---------------|-----------------|
| A. Cuneiform    | B. pictorial   | C. tomb walls | D. urban          | E. legible    | F. stone blocks |
| G. simple       | H. Mesopotamia | I. abstract   | J. papyrus sheets | K. decorative |                 |
| L. clay tablets | M. Egypt       | N. Uruk       |                   |               |                 |

## Reading 10

**Complete reading from Collin's**

## READING PASSAGE 1

**Affordable Art**

Art prices have fallen drastically. The art market is being flooded with good material, much of it from big-name artists, including Pablo Picasso and Andy Warhol. Many pieces sell for less than you might expect, with items that would have made £20,000 two years ago fetching only £5,000 to £10,000 this autumn, according to Philip Hoffman, chief executive of the Fine Art Fund. Here, we round up what is looking cheap now, with a focus on works in the range of £500 to £10,000.

Picasso is one of the most iconic names in art, yet some of his ceramics and lithographs fetched less than £1,000 each at Bonhams on Thursday. The low prices are because he produced so many of them. However, their value has increased steadily and his works will only become scarcer as examples are lost.

Nic McElhatton, the chairman of Christie's South Kensington, says that the biggest 'affordable' category for top artists is 'multiples' - prints such as screenprints or lithographs in limited editions. In a Christie's sale this month, examples by Picasso, Matisse, Miro and Steinlen sold for less than £5,000 each.

Alexandra Gill, the head of prints at the auction house, says that some prints are heavily hand-worked, or often coloured, by the artist, making them personalised. 'Howard Hodgkin's are a good example,' she says. 'There's still prejudice against prints, but for the artist it was another, equal, medium.'

Mr. Hoffman believes that these types of works are currently about as 'cheap as they can get' and will hold their value in the long run - though he admits that their sheer number means prices are unlikely to rise any time soon.

It can be smarter to buy really good one-offs from lesser-known artists, he adds. A limited budget will not run to the blockbuster names you can obtain with multiples, but it will buy you work by Royal Academicians [RAs] and others whose pieces are held in national collections and who are given long write-ups in the art history books. For example, the Christie's sale of art from the Lehman Brothers collection on Wednesday will include Valley with cornflowers in oil by Anthony Gross [22 of whose works are held by the Tate], at £1,000 to £1,500. There is no reserve on items with estimates of £1,000 or less, and William Porter, who is in charge of the sale, expects some lots to go for 'very little'. The sale also has oils by the popular Mary Fedden [whose works are often reproduced on greetings cards], including Spanish House and The White Hyacinth, at £7,000 to £10,000 each.

Large works by important Victorian painters are available in this sort of price range, too. These are affordable because their style has come to be considered 'uncool', but they please a large traditionalist following nonetheless. For example, the sale of 19th-century paintings at Bonhams on Wednesday has a Hampstead landscape by Frederick William Watts at £6,000 to £8,000 and a study of three Spanish girls by John Bagnold Burgess at £4,000 to £6,000. There are proto-social realist works depicting poverty, too, such as *Uncared For* by Augustus Edwin Mulready, at £10,000 to £15,000.

Smaller auction houses offer a mix of periods and media. Tuesday's sale at Chiswick Auctions in West London includes a 1968 screenprint of Campbells Tomato Soup by Andy Warhol, at £6,000 to £8,000, and 44 sketches by Augustus John, at £200 to £800 each. The latter have been restored after the artist tore them up. Meanwhile, the paintings and furniture sale at Duke's of Dorchester on Thursday has a coloured block print of Acrobats at Play by Marc Chagall, at £100 to £200, and a lithograph of a mother and child by Henry Moore, at £500 to £700. A group of five water colour landscape studies by Jean-Baptiste Camille Corot is up at £1,500 to £3,000.

Affordable works from lesser-known artists and younger markets are less safe, but they have the potential to offer greater rewards if you catch an emerging trend. Speculating



on such trends is high-risk, so is worthwhile only if you like what you buy [you get something beautiful to keep, whatever happens], can afford to lose the capital and enjoy the necessary research.

A trend could be based on a country or region. China has rocketed, but other Asian and Middle Eastern markets have yet to really emerge. Mr. Horwich mentions some 1970s Iraqi paintings that he sold this year in Dubai. 'They are part of a sophisticated scene that remains little-known.' Mr. Hoffman tips Turkey and the Middle East. Meanwhile, the Sotheby's Impressionist and modern art sale in New York features a 1962 oil by the Vietnamese Vu Cao Dam, a graduate of Hanoi's Ecole des Beaux Arts de l'Indochine and friend of Chagall, at \$8,000 to \$12,000 (£5,088 to £7,632). The painting shows two girls boating in traditional *ao dai* dresses.

A further way of making money is to try to spot talent in younger artists. The annual Frieze Art Fair in Regent's Park provides a chance to buy from 170 contemporary galleries. Or you could gamble on the future fame trajectory of an established artist's subject. For example, a Gerald Laing screenprint of The Kiss [2007] showing Amy Winehouse and her ex-husband is up for £4,700 at the Multiplied fair.

**QUESTIONS 1-5**

Use information from the passage to complete the table below Use NO MORE THAN TWO WORDS from the passage for each space.

Example of artist	Name of work/type of art form	Reason for low price
1. ....	Ceramics and lithographs	He produced many
2. ....	Valley with cornflowers	3. ....
John Bagnold Burgess Vu Cao Dam	A study of three Spanish girls 5. ....	4. .... Asian region ( except China) is not popular at the moment

**QUESTIONS 6-9**

Choose one of the endings [i—viii] from the List of Endings to complete each sentence below. Write the appropriate letters next to questions 6- 9. The information in the completed sentences should accurately reflect what is said in the text. NB There are more endings [i—viii] than sentence beginnings, so you will not need to use them all. You may use each ending once only

- 6. 'Multiples' are .....
- 7. Prints are .....
- 8. Gross and Fedden are .....
- 9. Victorian painters are .....

**List of Endings**

- i. artists that have never been popular at all.
- ii. hand-made and personal art works.
- iii. items that are not really popular with buyers but good value for money.
- iv. artists that seem to like real life topics.
- v. top artists that sell many works.
- vi. artists who have used a particular type of material.
- vii. relatively cheap limited editions prints.
- viii. artists whose work is not often seen by the wider public.

**QUESTIONS 10-13**

Do the following statements agree with the information given in Reading passage 1? Write:

- TRUE if the statement agrees with the information
- FALSE if the statement contradicts the information
- NOT GIVEN if there is no information on this in the passage

- 10. Picasso, Warhol, Matisse, Miro and Steinlen are big-name artists.
- 11. It is possible to buy a painting by Picasso for less than £5,000.
- 12. Greeting cards can sell for up to £10,000 each.
- 13. It is not worth investing in new artists or markets because there is a great risk of losing all your money

## READING PASSAGE 2

A

The race to reach 33 miners entombed for 64 days 700m [2,300ft] below the bare brown mountains of the Atacama Desert in Chile could be completed as early as tonight. The chief engineer said this afternoon that within 24 hours the chamber will have been reached. He added that bringing the miners out could begin in three days' time. Three giant drills were boring rescue shafts down through the layers of rock, Laurence Golborne, the Mining Minister, had announced yesterday. How quickly the miners can be extracted once the shafts have reached the men depends on a careful inspection of the shaft, 70cm [28in] wide, by video cameras. If the rock walls are deemed stable the miners could be brought out, one by one, within another two or three days. It is estimated that it will take between 36 and 48 hours to bring them all out.

B

The miners have been trapped underground since August 5, more than twice as long as any other known survivor of a mining accident. A stream of rescue vehicles, satellite television trucks and vehicles carrying journalists from around the world are heading up to the shallow bowl in this lunar landscape that will be a centre of attention over the next few days. In the past 48 hours a specially trained 16-man rescue team, three slim metal rescue capsules, a giant crane, winches and much other equipment have been delivered to Camp Esperanza, as the makeshift settlement is known.

C

Once the shaft is safe, two volunteers, a mining expert from Codelco, the state-owned mining conglomerate, and Sergeant Roberto Rios Seguel, 34, a naval medic and commando, will act as human guinea pigs, descending to where the miners are in the Phoenix - a steel capsule specially made by the Chilean Navy and designed by them together with NASA engineers. It has been painted in the red, white, and blue colours of the Chilean flag. The Phoenix is named for the mythical bird that rose from its ashes, and is the biggest of three custom-built capsules that will be used. It weighs 420 kg. Its interior height is 6 feet, 4 inches [1.9 metres]. The miners have been restricted to a diet of 2,000 calories a day to ensure that they can fit into the capsule, which is 53cm wide. The capsule has oxygen tanks in the bottom part. It also has a camera, its own lighting system and a sound system. It has two sets of retractable wheels around it, one near the top and one near the bottom, to help it travel up and down the rescue shaft. The roof of the capsule contains LED lights. If something goes wrong during the rescue, the top part of the capsule can be released and the bottom two thirds of the capsule would then be lowered back down. Should the capsule become jammed, the occupant can open the escape hatch in the base and go back down the shaft.

D

The capsule will be lowered by a large crane at a speed of up to 3ft [91cm] per second. The miners will be wearing a suit with a harness over it, which will allow them to be strapped to the centre of the cylinder in an upright position for the estimated twenty-minute journey to the surface. They will also wear an oxygen mask, a pair of dark glasses to protect their eyes from exposure to the desert sunlight, and a helmet which is specially adapted with a microphone and a wired headset to enable them to communicate with the surface. Doctors will monitor the miners' vital signs using information gathered from a biometric belt. They will conduct a preliminary assessment of the miners' mental and physical health. The miners will then be divided into three groups. The strongest will be the first to make the hazardous ascent to freedom, in case the capsule hits problems, then the weakest. They will be winched up one by one in the slender capsule, rising at just under a metre a second, meaning that each ascent will take about 15 minutes. The entire rescue is expected to take 30 to 40 hours.

E

As each man finally emerges, he will be taken to the nearby field hospital wearing Californian-made sunglasses that filter out all UV rays to protect his eyes. There the men will be given a thorough check-up and, if strong enough, they will be allowed to meet three relatives

designated in advance. The miners will then be flown by helicopter to the hospital in Copiapo, where a whole floor has been set aside for them. They are expected to remain there for at least two days.

**QUESTIONS 14-15**

Reading Passage 2 has five paragraphs A-E. Which paragraphs state the following information? Write the appropriate letters A-E. NB There are more paragraphs than summaries, so you will not use them all.

14. The miners' situation is of global interest.

15. The length of the operation will be determined by the stability of the physical environment.

**QUESTIONS 16-20**

Complete the summary below. Choose your answers from the box below the summary and write them into spaces 16-20. You can only use each answer once.

NB There are more words than spaces so you will not use them all.

However, if all goes well, they could be 16.....by 17..... emergency workers in the next few days. Preparations are already under way. As soon as the miners have been 18....., the real rescue operation can start: a specially 19 ..... capsule will be sent down to retrieve them one by one. It is 20.....that bringing all of the men back up will take up to forty hours.

trapped	made safe	designed	estimated
trained	freed	completed	known
reached	guessed	carried	restricted

**Questions 21-26**

Using no more than three words from the passage, complete each blank in the diagram below

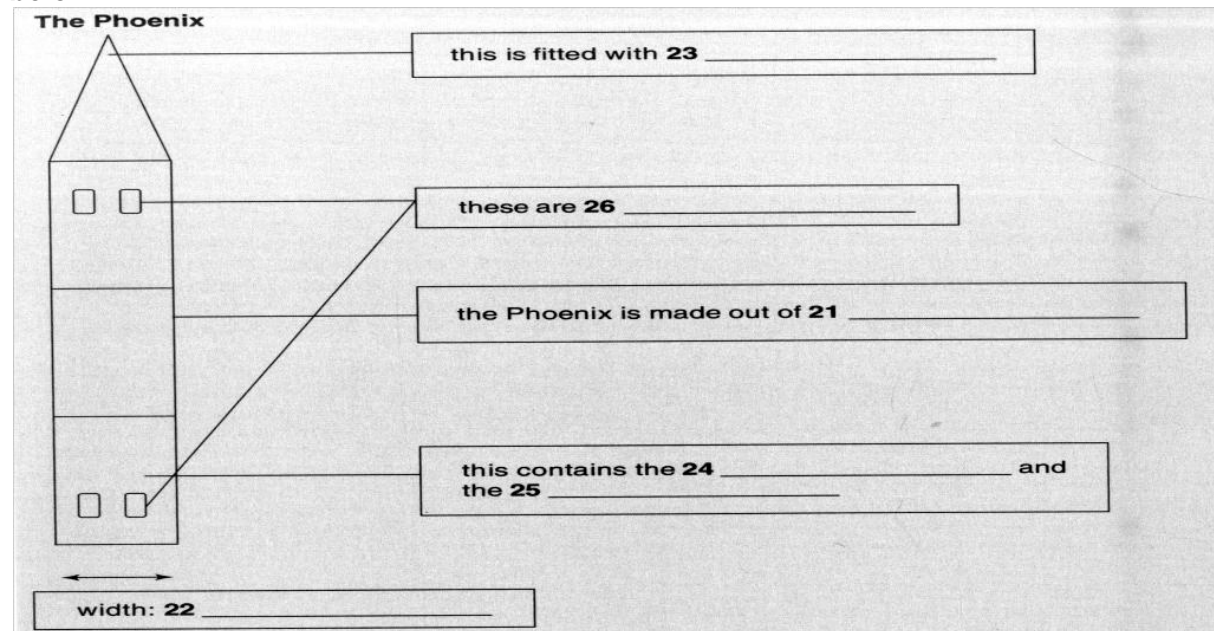

**QUESTION 27**

From the list below; choose the most suitable title for the whole of Reading Passage 2. Write the appropriate letter A-D.

- A. Mine rescue on verge of breakthrough
- B. Journalists and rescuers race to Chile
- C. Engineers save the day
- D. The Phoenix will rise

## READING PASSAGE 3

**High-tech crime-fighting tools**

A

Crime-fighting technology is getting more sophisticated and rightly so. The police need to be equipped for the 21st century. In Britain we've already got the world's biggest DNA database. By next year the state will have access to the genetic data of 4.25m people; one British-based person in 14. Hundreds of thousands of those on the database will never have been charged with a crime.

B

Britain is also reported to have more than £4 million CCTV [closed circuit television] cameras. There is a continuing debate about the effectiveness of CCTV. Some evidence suggests that it is helpful in reducing shoplifting and car crime. It has also been used to successfully identify terrorists and murderers. However, many claim that better lighting is just as effective to prevent crime and that cameras could displace crime. An internal police report said that only one crime was solved for every 1,000 cameras in London in 2007. In short, there is conflicting evidence about the effectiveness of cameras, so it is likely that the debate will continue.

C

Professor Mike Press, who has spent the past decade studying how design can contribute to crime reduction, said that, in order for CCTV to have any effect, it must be used in a targeted way. For example, a scheme in Manchester records every licence plate at the entrance of a shopping complex and alerts police when one is found to belong to an untaxed or stolen car. This is an effective example of monitoring, he said. Most schemes that simply record city centres continually - often not being watched - do not produce results. CCTV can also have the opposite effect of that intended, by giving citizens a false sense of security and encouraging them to be careless with property and personal safety. Professor Press said: 'All the evidence suggests that CCTV alone makes no positive impact on crime reduction and prevention at all. The weight of evidence would suggest the investment is more or less a waste of money unless you have lots of other things in place.' He believes that much of the increase is driven by the marketing efforts of security companies who promote the crime-reducing benefits of their products. He described it as a 'lazy approach to crime prevention' and said that authorities should instead be focusing on how to alter the environment to reduce crime.

D

But in reality, this is not what is happening. Instead, police are considering using more technology. Police forces have recently begun experimenting with cameras in their helmets. The footage will be stored on police computers, along with the footage from thousands of CCTV cameras and millions of pictures from number plate recognition cameras used increasingly to check up on motorists.

E

And now another type of technology is being introduced. It's called the Microdrone and it's a toy-sized remote-control craft that hovers above streets or crowds to film what's going on beneath. The Microdrone has already been used to monitor rock festivals, but its supplier has also been in discussions to supply it to the Metropolitan Police, and Soca, the Serious Organised Crime Agency. The drones are small enough to be unnoticed by people on the ground when they are flying at 350ft. They contain high-resolution video surveillance equipment and an infrared night vision capability, so even in darkness they give their operators a bird's-eye view of locations while remaining virtually undetectable.

F

The worrying thing is, who will get access to this technology? Merseyside police are already employing two of the devices as part of a pilot scheme to watch football crowds and city parks looking for antisocial behaviour. It is not just about crime detection: West Midlands fire brigade is about to lease a drone, for example, to get a better view of fire and flood scenes and aid rescue attempts; the Environment Agency is considering their use for monitoring of illegal fly tipping and oil spills. The company that makes the drone says it has no plans to license the equipment to individuals or private companies, which hopefully will prevent private security firms from getting their hands on them. But what about local authorities? In theory, this technology could be used against motorists. And where will the surveillance society end? Already there are plans to

introduce 'smart water' containing a unique DNA code identifier that when sprayed on a suspect will cling to their clothes and skin and allow officers to identify them later. As long as high-tech tools are being used in the fight against crime and terrorism, fine. But if it's another weapon to be used to invade our privacy then we don't want it.

**Glossary:**

drone: a remote-controlled pilotless aircraft  
 350ft: about 107 meters  
 bird's eye view: a view from above  
 fly-tipping: illegally dumping waste [British English]

**QUESTIONS 28-32**

Reading Passage 3 has six paragraphs A-F. Choose the most suitable headings for paragraphs B-F from the list of headings below. NB There are more headings than paragraphs, so you will not use them all.

**List of Headings**

- i. The spy in the sky
- ii. The spread of technology
- iii. The limitations of cameras
- iv. The cost of cameras
- v. Robots solving serious crimes
- vi. Lack of conclusive evidence
- vii. Cars and cameras
- viii. Advantages and disadvantages
- ix. A natural progression
- x. A feeling of safety

- |   |
|---|
| <ul style="list-style-type: none"> <li>28. Paragraph B</li> <li>29. Paragraph C</li> <li>30. Paragraph D</li> <li>31. Paragraph E</li> <li>32. Paragraph F</li> </ul> |
|---|

**Example - Paragraph A**

**Answer - ix**

**QUESTIONS 33-35**

Choose the appropriate letters A-D to finish sentences 33-35.

33. Britain has already got
- A. four million CCTV cameras.
  - B. more data about DNA than any other country.
  - C. the most sophisticated crime-fighting technology.
  - D. access to the genetic data of one in fourteen people living in Britain.
34. Professor Press
- A. works at the University of Manchester.
  - B. studies car-related crime.
  - C. is concerned about the negative impact of the use of CCTV.
  - D. feels that some marketing departments lie about the crime-reducing benefits of CCTV.
35. The Microdrone is
- A. a type of toy in the shape of a plane.
  - B. being used by the Metropolitan Police.
  - C. being used by the government.
  - D. able to film in the dark.

**QUESTIONS 36-37**

Using NO MORE THAN THREE WORDS from the passage, answer the following questions.

36. Give examples of 2 events where technology is used to watch crowds

37. According to the passage, who do we not want to use the Microdrone?

**QUESTIONS 38-40**

Do the following statements agree with the views of the writer in Reading Passage 3? Write:

YES if the statement agrees with the views of the writer

NO if the statement contradicts what the writer thinks.

NOT GIVEN if it is impossible to know what the writer's point of view is.

38. The British authorities use too much technology to monitor their citizens.

39. Microdrone is currently not used to check drivers.

40. Technology should not be used to check on people's private affairs.

## Reading 11

## FOCUS ACAD SKILLS READING

**BRIDGING THE DIGITAL DIVIDE**

*When addressing the issue of global access to information technology, some people claim that the world's poor are more concerned about having enough to eat than about using e-mail or surfing the World Wide Web.*

*Mike Chege disagrees.*

- A. In what concrete ways can information and communication technologies (ICTs) benefit the two-thirds of humanity who are more concerned about their next meal than about e-mail or eBay?
- B. First, there are the economic advantages of these technologies. Besides providing business with the opportunity to access real-time market information and complete business transactions electronically, ICTs can reduce costs and provide a channel to market goods and services. One small company from Tanzania replaced \$20 faxes with 10 cent e-mails and saw its telecommunications bill go from over \$500 per month to \$45 per month. In the business-to-consumer segment you will find examples like EthioGift.com which sells gifts, including sheep and goats, over the Internet. And in India, which is fast becoming a global centre for telemarketing, customer support and other call centre services, ICTs are transforming the economy. With the legalisation of Internet telephony, India has captured an even bigger chunk of the global outsourcing market, with calls from the US accounting for 80 per cent of call centre business. Schools are even training young men and women to speak in an American accent in order to handle the calls.
- C. Health services also benefit from ICTs. Using the Internet, doctors in poor countries can keep up to speed with the latest developments in their field as well as seek help from their peers. This technology can also facilitate the control of diseases. Throughout Africa, for instance, individual cases of meningitis are tracked over the Internet so that epidemics can be stopped early. In addition, ICTs can assist in allowing healthcare professionals to extend their reach through telemedicine into the remotest and most underserved areas.
- D. ICTs can make it easier to reach a broad segment of the population in education too. The African Virtual University is a distance learning project which is partly financed by the World Bank, and which serves the countries of sub-Saharan Africa. The Virtual University uses satellites to broadcast televised courses to students who communicate with teachers by e-mail and telephone.
- E. Finally, we come to what has been dubbed 'e-government'. E-government initiatives focus on making government transparent and accountable by providing citizens with direct access to information. Critics might argue that when you're being stalked by war, hunger and disease, this may not be a priority. But e-government is about more than just the ability to pay your taxes online or apply for a driving licence over the Internet. It is about giving citizens access to information which allows them to make informed decisions on subjects that affect their lives.
- F. But how can those people who need ICT capabilities most, be best helped to bridge the Digital Divide? Throwing computers and modems at people (as someone colourfully put it) will not in itself help much. Other important issues that need to be addressed include improving computer and keyboarding skills and increasing people's confidence in their ability to use the new technology.
- G. A good example of how this can be done is the Information Village Project, a computer intra net linking ten villages near Pondicherry, India. The project, started with a \$120,000 grant from the International Development Research Centre, Canada, provides locally relevant information on product prices, healthcare, weather and fishing conditions. A team of volunteers from each village gathers up the information and feeds it into the computer in the local language (Tamil). It is then available to all users of the intranet. There is also a multimedia component to make the information accessible to illiterate users. Most of the operators and volunteers providing the primary information are women, and their role in the project raises their status in the community. Since most of the villages experience erratic power supply, the project can run on solar power as well as mains electricity.
- H. Another Indian creation, the Simputer (short for Simple, Inexpensive, Multilingual computer) was conceived by a team of computer scientists at the Indian Institute of Science in Bangalore. It is a small, hand-held, battery-powered computer about 12 cm by 7 cm that has a touch-sensitive screen. You use a stylus to tap on icons and to input information. Because each display page

shows only a few possible commands, even illiterate users should be able to learn by trial and error the purpose of the icons and buttons on each page. The Simputer also has software that can turn text into speech. This works for various Indian languages and allows the Simputer to read the text aloud on its tiny built-in speakers. It also has a slot for 'smart' cards, a feature that its makers see as crucial. Because the device lacks a hard drive, smart cards act as the device's portable storage units. In this way, many people can use one Simputer without having to share their private information with one another. The Simputer costs \$200 - a sizable chunk of the yearly per capita income for many of its users. But one Simputer can enable an entire village to access the Internet, perform transactions, keep track of agricultural prices and educate its children.

- I. So bridging the Digital Divide is not something that happens after addressing the 'core' development challenges; it is a key component of addressing those challenges in the 21st century. Failure to address the Digital Divide will only exacerbate the existing social and economic inequalities between countries and communities.

**Questions 1-5**

Complete the sentences below with words taken from the Reading Passage. Use **NO MORE THAN THREE WORDS** for each answer.

- The example of the Tanzanian company's telecommunications bill demonstrates how information and communication technology can cut .....
- In Africa, use of the Internet enables .....of diseases such as meningitis to be controlled.
- An international organisation has subsidised a .....scheme in Africa which depends on ICTs.
- E-government provides people with a source of .....so they can make their own choices in life.
- In order to allow global use of ICTs, people need to have the skill and ..... to use this technology.

**Questions 6-11**

Classify the following features according to whether they apply to

- the Information Village Project only
  - the Simputer only
  - both the Information Village Project and the Simputer
  - neither the Information Village Project nor the Simputer
- use of the technology is not limited to individuals
  - information can be kept secure and private by individual users
  - must have a mains electricity supply
  - initially supported by an overseas agency
  - can only be used by people who can read and write
  - knowledge of English not required

**Questions 12-14** Choose the best answer, A, B, C or D.

- What reason is given for the increasing importance of call centres to the Indian economy?
  - the availability of workers with the right accent
  - a change in the legal system
  - local familiarity with outsourcing techniques
  - the country's geographical position
- The writer says that in both health and education
  - more training is needed in the use of ICTs.
  - international organisations need to provide more support with ICTs.
  - ordinary people are gaining more skill in the use of ICTs.
  - ICTs can help to provide services to more people than before.
- Overall the writer's main argument in this passage is that
  - ICT access is a basic need for a fairer world.
  - the digital divide is the cause of our present inequalities.
  - the developed world should do more to provide ICT training.
  - the digital divide may never be successfully bridged.

## Passage 2

**Genetically modified crops: accepting the inevitable?**

- A. Cabaceiras is a town of around 5,000 people situated in Brazil's northern state of Para. The people are mostly small-scale vegetable farmers, with specialist, traditional knowledge handed down over hundreds of years. But now the natural purity of their produce is under threat from one of the 21st century's most controversial technological issues: genetically modified organisms (GMOs). Previously one of the world's last major agricultural exporters to remain GMO free, the Brazilian government has now decided to allow the biotechnology industry to sell GM seed to the country's farmers.
- B. Many people in Brazil feel the acceptance of transgenic crops is a dangerous move. Before this decision, Brazil was the world's largest exporter of GM-free soya. In 2001, sales of this product alone earned the country US\$ 4.1 billion - just under one-third of the country's total income from agricultural exports. Its main market was Europe, where consumers are still suspicious as to whether food species that have been genetically engineered in a laboratory may affect their health. Several UK supermarket chains, for example, insist on GM-free soya and refuse to buy from the USA, where 69 per cent of all soya crops are GM.
- C. European law requires all produce containing more than one per cent of GM ingredients to be labelled as such. At the time when Brazil was totally GM-free, Adriano Campolini, policy director of the development agency ActionAid, pointed out, 'Brazil faces pressure from countries like the USA and from the biotech industry to come into line. They are afraid that Brazil will have a competitive advantage because of its GM-free status.' Fearful that health and safety worries were being ignored, ActionAid joined with other non-governmental organisations to stall attempts in Brazil's congress to legalise GMOs, insisting there must be further research. They gained support among rural peasants such as those who live in Cabaceiras through a public education campaign, staging mock jury trials at which scientists, large-scale farmers, peasants and civic leaders alike were invited to debate the case for and against.
- D. Even now, small family farmers like Lilian Marques, 33, who lives in Cabaceiras with her family, fear GM technology could harm them and their businesses. Lilian is well aware of the possible effects on health of eating GM food, but she also has other concerns, 'I am afraid that the rich farmers will plant GM seed now it is legalised,' she explains. 'The wind could bring the pollen to our plantation, then it will be as if we have planted GM seed too. We produce only natural vegetables, yet we could not be sure what we were eating.'
- E. There are other potential consequences that trouble many in this fragile Amazon region, whose biodiversity is the richest on the planet. Some fear there may be a risk of chemical pollution from the products that must be used on the crops. One type of GM maize has even been engineered to be insect-resistant - if a caterpillar eats the leaf, the caterpillar dies. 'Maybe GM crops could be harmful to the forest and the animals that we eat,' Lilian suggests. 'What if an insect eats from the crop, then an animal eats the insect, then we eat the animal?'
- F. The biotech industry says such fears about GM technology are misguided. Monsanto, the international food biotechnology company, has launched a campaign in Brazil, costing US\$ 2 million, to provide information to the public about genetically modified crops. The company insists the process that kills the insects is harmless to humans and that 'Round-up' - the herbicide used on GM crops - is 'no more toxic than table-salt'. 'We are as close to 100 per cent as science can ever be that GM products are safe for human health and the environment,' says spokesman Gary Barton. Monsanto hails the USA and Argentina - the other two largest exporters of soya - as examples of agricultural exporters that thrive on GM crops, whose merits it says include increased resistance to disease, improved nutritional value and increased levels of production. 'Three and a half million farmers around the world wouldn't have adopted biotechnology in their fields if they weren't seeing any benefits,' says Barton.



- G. It is not just the biotechnology companies that have an interest in Brazil lifting its GM ban, though they will undoubtedly reap the biggest profits. Francisco Campos, a professor of plant molecular biology in the north eastern city of Fortaleza, has made his own scientific breakthrough but cannot implement it because the embargo has only been lifted on GM soya, not other crops. 'We need plants to feed animals in order to have milk and meat. In this region, most of the plants we use for animal food, like cassava and prickly pear, are nutritionally deficient. But we can now insert a gene to add nutritional quality. In my laboratory, we have created our first transgenic cassava like this, but we are not allowed to put it to use. This GM ban undermines the confidence people have in science and its ability to help feed our nation.'
- H. But the villagers in Cabaceiras are not convinced. 'In my view, people still don't know if GM seed is good or bad,' says Lilian. 'Therefore, I don't want to take the risk.'

#### Questions 15-22

The reading passage has eight paragraphs labelled A-H. Which paragraph contains the following information? NB You may use any letter more than once.

15. an example of a part of the world which valued Brazil's GM-free status
16. an important decision that has been made by Brazilian authorities
17. an account of one organisation's efforts to reassure the people of Brazil about GMOs
18. the effect on public attitudes to science of the continued ban on some GM techniques
19. the reason why other countries felt threatened by Brazil's ban on GM products
20. an example of a small community which has, up to now, been free of GMOs
21. a warning about the possible effects of GM technology on the food chain
22. a method of raising awareness of both positive and negative aspects of GMOs

#### Questions 23-27

Complete the notes below. Choose NO MORE THAN THREE WORDS from the passage for each answer.

#### Arguments against GM technology

- a. health could be affected by eating GM foods
- b. danger of 23.....from GM crops being carried to plantations of non-GM produce.
- c. danger of 24..... from products such as insecticides

#### Arguments for GM technology

- a. insecticide and 25 ..... products used on GMOs are safe
- b. GM crops bring many benefits
  - e.g. less danger of 26.....
  - more nutritious
  - more productive
- c. already used by 3.5 m farmers world-wide
- d. new type of 27 .....plant developed through the insertion of an extra gene could improve yields of meat and milk if used as animal food.

#### Question 28

Choose the correct letter, A, B, C or D.

Which of these statements best summarises the reading passage?

- A. The concerns of ordinary people about GMOs should not be dismissed.
- B. The environmental and economic disadvantages of GM use outweigh the advantages.
- C. Multinational companies should not be allowed to restrict the use of GM technologies.
- D. Uneducated people should be reassured about the value of GMOs.

## Passage 3

**CUTE buses: a new direction for public transport**

*It seems like an ordinary bus except that it moves almost silently and it does not give off any exhaust fumes. Instead, a small cloud of white steam emerges from the roof. But this is no ordinary vehicle. It is part of an experiment that could revolutionise public transport in our cities, providing sustainable, non-polluting transport from renewable energy resources.*

- A. Urban transport is a major problem in the countries of the European Union, where over 75% of the population lives in towns and cities. It is becoming increasingly difficult to reconcile individual needs and expectations of personal mobility with the preservation of the fabric of our cities and with the quality of life of their inhabitants. Transport is already one of the chief contributors to health and environmental problems in urban regions, and increasing levels of congestion mean that in some cities the average speed of traffic at peak times is slower than 11 was in the days of the horse and cart. In addition, exhaust fumes are a major contributor to rising levels of CO<sub>2</sub> emissions in the atmosphere, as well as being a source of carbon monoxide and particulate matter. With experts forecasting an increase of 30% in the total number of kilometres travelled by 2030, urban transport systems have to face the challenge of meeting citizens' needs for mobility through the development of innovative and sustainable methods of transport.
- B. To address this problem, the European Commission has allocated €18.5m to a project entitled CUTE (Clean Urban Transport for Europe), one of the most ambitious experiments in energy and transport taking place today. The aim of the project is to investigate the role that hydrogen and fuel cells could play in providing a safe, clean and efficient means of public transport. In order to do this, the nine participating cities have each been supplied with three buses which are powered by hydrogen rather than by diesel fuel. The buses, produced by Mercedes Benz Citaro, contain tanks of compressed hydrogen in the roof, which supply fuel cells. Here, the hydrogen molecules are split and electricity is produced to power the bus, together with pure water which escapes into the atmosphere as steam. The buses only need refuelling once a day and can travel at speeds of up to 100kph.
- C. The nine participating cities vary widely in their local conditions and the type of operating systems they use, allowing data to be collected and comparisons to be made between the different systems. One decision the transport authorities in each city have to make is the source of the hydrogen they use for fuel. This may be produced either from renewable resources, or from fossil fuels. At present only around 40% of the energy required for the production of hydrogen on the project comes from renewable resources such as wind power. Amsterdam and Hamburg both use energy from this source to produce the hydrogen for their buses. Stockholm also uses a renewable resource, in this case hydro power, while Barcelona profits from its high number of hours of sunshine to make use of solar power. In cases such as these it may be possible to have a zero emission system, with no harmful by-products given off at any stage of the project. However, other cities such as Porto and London use natural gas or other non-renewable resources to produce the hydrogen.
- D. In addition to deciding on the means of production, the cities also have to decide on the location where the production of hydrogen is to take place. The on-site production of hydrogen removes the need for its transportation by truck in liquid or gas form, which is again an advantage in ecological and financial terms; this solution is used by several cities including Madrid. In London, however, in order to make the hydrogen available to other users, the authorities decided against on-site production, so the hydrogen production plant is some way from the bus depot.
- E. The varying geographical and climatic conditions of each city also allow information to be collected on a range of operating conditions for the buses. In some cities, such as London, buses have to be able to perform in congested traffic, while in Madrid and Porto in summer they have to be able to contend with the hot climate in addition to this. Bus transport in Porto also has to cope with extreme geographical conditions since the city is built on a steep hillside, and the same is true of Luxembourg and Barcelona. In Stuttgart, on the other hand, which has a widespread population, the buses' ability to travel long distances is tested.
- F. The overall remit of the project therefore involves comparison of performance and costs involved in three main areas: the production of hydrogen, the organisation of infrastructure (for example, the location of hydrogen refilling stations), and the use of the buses in varying operational

conditions. There is still some way to go before hydrogen buses will be replacing ordinary public transport on a large scale - at present running costs are ten times higher, which does not make them a commercial proposition - but it is beginning to look as if the days of the diesel driven bus are numbered.

**Questions 29-33**

Do the following statements agree with the information given in the reading passage? Write

- TRUE if the statement agrees with the information
- FALSE if the statement contradicts the information
- NOT GIVEN if there is no information on this

29. Traffic may cause problems both to city buildings and to residents.
30. The most efficient way to solve urban transport problems is to increase the use of public transport.
31. The chemical reaction which produces power for the hydrogen bus takes place in the fuel cell.
32. The authorities in each city are responsible for the initial collection and analysis of the data.
33. The nine cities in the CUTE project have zero emission systems for their hydrogen buses.

**Questions 34-37**

The reading passage has six paragraphs labelled A-F. Which paragraph contains the following information?

**NB** You may use any letter more than once.

34. a contrast between the two main methods of hydrogen production
35. a reason why hydrogen powered buses may not be widely used for some time
36. a comparison of traffic conditions in the past and present
37. a justification for the transportation of hydrogen by road to refuel London buses

**Questions 38-42**

Complete the labels on the diagram. Choose **NO MORE THAN THREE WORDS FROM THE PASSAGE** for each answer.

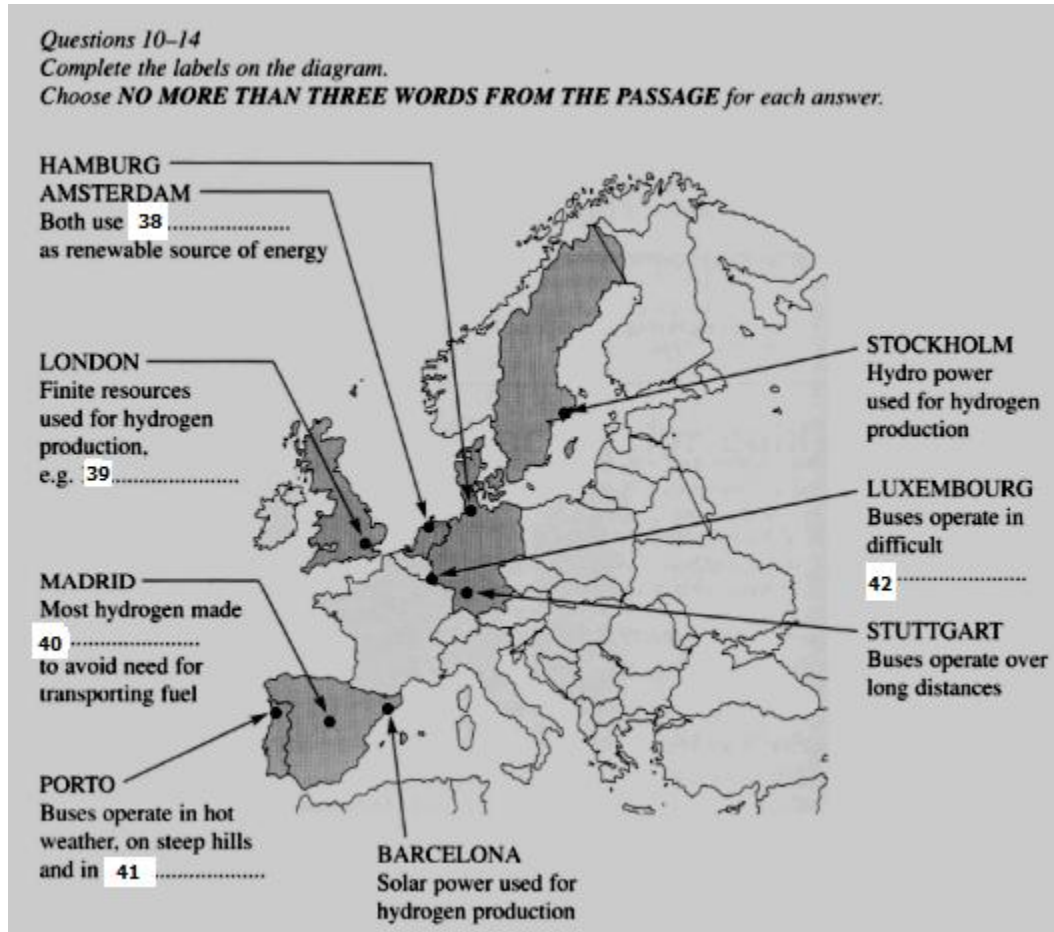

**Reading 12** **Focus on IELTS Complete reading**  
**READING PASSAGE 1**

**The Birth of Blue**

*As a primary colour, blue has been the most difficult for artists and scientists to create.*

Artists have always been enchanted by blue, yet fine blues have long been difficult to obtain. Blues are relatively rare in nature, and painters throughout the ages have therefore found themselves at the mercy of what contemporary chemical technology could offer. Some blues have been prohibitively expensive, others were unreliable. The quest for a good blue has driven some crucial technological innovations, showing that the interaction of art and science has not always been a one-way affair.

The first pigments were simply ground-up coloured minerals dug from the earth. But few blue minerals are suitable as pigments – so there are no blues in cave art. Ancient Egyptian artists used blue prominently; however, because they knew how to make a fine artificial pigment, now known as Egyptian blue.

The discovery of Egyptian blue, like that of many other artificial pigments, was almost certainly an accident. The Egyptians manufactured blue-glazed stones and ornaments called faience using a technique they inherited from the Mesopotamians. Faience manufacture was big business in the ancient world - it was traded all over Europe by 1500 BC. Faience is made by heating stone ornaments in a kiln with copper minerals such as malachite. Egyptian blue, which was made from at least 2500 BC, comes from firing chalk or limestone with sand and copper minerals, and probably appeared by the chance mixture of these ingredients in a faience kiln.

Scientists recently deduced the secrets of another ancient blue: Maya blue, used for centuries throughout Central America before the Spanish Conquest. This is a kind of clay - a mineral made of sheets of atoms - with molecules of the blue dye indigo wedged between the sheets. Using indigo in this way, makes it less liable to decompose. No one has made colours this way since the Mayas, and no one knows exactly how they did it. But technologists are now interested in using the same trick to make stable pigments from other dyes.

The finest pigment available to medieval artists was ultramarine, which began to appear in Western art in the 13<sup>th</sup> century. It was made from the blue mineral lapis lazuli, of which only one source was known: the remote mines of Badakshan, now in Afghanistan. In addition to the difficulty of transporting the mineral over such distances, making the pigment was a tremendously laborious business. Lapis lazuli turns grayish when powdered because of impurities in the mineral. To extract the pure blue pigment, the powder has to be mixed to a dough with wax and kneaded repeatedly in water.

As a result, ultramarine could cost more than its weight in gold, and medieval artists were very selective in using it. Painters since the Renaissance craved a cheaper, more accessible, blue to compare with ultramarine. Things improved in 1704, when a Berlin-based colour maker called Diesbach discovered the first "modern" synthetic pigment: Prussian blue. Diesbach was trying to make a red pigment, using a recipe that involved the alkali potash. But Diesbach's potash was contaminated with animal oil, and the synthesis did not work out as planned. Instead of red, Diesbach made blue.

The oil had reacted to produce cyanide, a vital ingredient of Prussian blue. Diesbach kept his recipe secret for many years, but it was discovered and published in 1724, after which anyone could make the colour. By the 1750s, it cost just a tenth of ultramarine. But it wasn't such a glorious blue, and painters still weren't satisfied. They got a better alternative in 1802, when the French chemist Louis Jacques Thenard invented cobalt blue.

Best of all was the discovery in 1826 of a method for making ultramarine itself. The French Society for the Encouragement of National Industry offered a prize of 6,000 francs in 1824 to anyone who could make artificial ultramarine at an affordable price.

The Toulouse chemist Jean-Baptiste Guimet was awarded the prize two years later, when he showed that ultramarine could be made by heating china clay; soda, charcoal, sand and sulphur in a furnace. This meant that there was no longer any need to rely on the scarce natural source, and ultramarine eventually became a relatively cheap commercial pigment (called French ultramarine, as it was first mass-produced in Paris).

In the 1950s, synthetic ultramarine became the source of what is claimed to be the world's most beautiful blue. Invented by the French artist Yves Klein in collaboration with a Parisian paint manufacturer, Edouard Adam, International Klein Blue is a triumph of modern chemistry. Klein was troubled by how pigments lost their richness when they were mixed with liquid binder to make a paint. With Adams help, he found that a synthetic resin, thinned with organic solvents, would retain this vibrant texture in the dry paint layer. In 1957, Klein launched his new blue with a series of monochrome paintings, and in 1960 he protected his invention with a patent.

#### Questions 1-4

Complete the summary below. Choose **NO MORE THAN THREE WORDS** from the passage for each answer

The colours used in cave paintings and other early art were made by crushing 1 ..... . However, later artists have generally had to rely on the 2 ..... of the day for their supplies of blue. Among the first examples of the widespread use of blue was in 3 ..... art. Over the centuries, many more attempts to create acceptable blues have been made, some of which have led to significant 4 .....

#### Questions 5 and 6

Choose the correct letter A, B, C or D.

5. What was the main disadvantage in using ultramarine for medieval artists?
- It contained a number of impurities.
  - It was excessively expensive.
  - The colour wasn't permanent.
  - The preparation process was hazardous.
6. The discovery of Prussian blue was the result of
- using the wrong quantity of an ingredient.
  - mixing the wrong ingredients together.
  - including an ingredient that was impure.
  - using an ingredient of the wrong colour.

#### Questions 7-13

Look at the descriptions and the list of types of blue below. Match each description with the type of blue

- developed in the early years of the 19th century .....
- derived from a scarce natural resource .....
- specially designed to retain its depth of colour when used in paint .....
- was cheap to produce but had limited appeal for artists .....
- made using a technique which is not yet fully understood .....
- thought to have been produced during another manufacturing process .....
- came to be manufactured inexpensively in large quantities .....

#### Types of Blue

- Egyptian blue
- Maya blue
- Ultramarine
- Prussian blue
- cobalt blue
- French ultramarine
- International Klein Blue

**READING PASSAGE 2****Questions 14-18**

Complete each sentence with the correct ending A-I from the box below.

14. Napier grass .....
15. The plant called Striga .....
16. Growing single crops .....
17. Ploughing the land .....
18. Sowing black oats .....

- A. reduces losses due to plant diseases.
- B. can lead to soil erosion.
- C. causes major financial losses.
- D. increases soil fertility.
- E. discourages the growth of weeds.
- F. helps to retain carbon dioxide.
- G. destroys harmful insect larvae.
- H. helps prevent global warming.
- I. encourages pests to breed.

**Questions 19-26**

Complete the table below. Choose NO MORE THAN THREE WORDS from the passage for each answer.

Area	Strategy	Benefits to farmers
East Africa	19 ..... with food crop.	Lower costs Higher yields
20 .....	Growing mixed crops together.	Higher yields
Madagascar	Transplanting seedlings earlier. Leaving paddy fields unflooded. Replacing chemical fertilisers with 21 .....	Higher yields
Cuba	Reducing 22 ..... Using 23 .....instead of farm vehicles Growing mixed crops together.	Yields doubled Citizens' 24 .....increased.
Latin America	Zero-tillage	Lower costs Improved 25 ..... Higher yields Higher 26 .....

### An ordinary miracle

*Bigger harvests, without pesticides or genetically modified Crops? Farmers can make it happen by letting weeds do the work.*

Across East Africa, thousands of farmers are planting weeds in their maize fields. Bizarre as it sounds, their technique is actually raising yields by giving the insect pests something else to chew on besides maize. "It's better than pesticides, and a lot cheaper," said Ziadin Khan, whose idea it is, as he showed me round his demonstration plots at the Mbita Point research station on the shores of Lake Victoria in Kenya. "And it has raised farm yields round here by 60 to 70 per cent."

His novel way of fighting pests is one of a host of low-tech innovations boosting production by 100 per cent or more on millions of poor Third World farms in the past decade. This "sustainable agriculture" just happens to be the biggest movement in Third World farming today dwarfing the tentative forays into genetic manipulation.

In East Africa, maize fields face two major pests, and Khan has a solution to both. The first is an insect called the stem borer, whose larvae eat their way through a third of the region's maize most years. But Khan discovered that the borer is even fonder of a local weed, napier grass. By planting napier grass in their fields, farmers can lure the stem borer away from the maize – and into a honey-

trap. For the grass produces a sticky substance that traps and kills stem borer larvae. The second pest is Striga, a parasitic plant that wrecks \$10 billion worth of maize crops every year, threatening the livelihoods of 100 million Africans. "Weeding Striga is one of the most time-consuming activities for millions of African women farmers," says Khan. But he has an antidote: another weed called Desmodium. "It seems to release another sort of chemical that Striga doesn't like. At any rate, where farmers plant Desmodium between rows of maize, Striga won't grow."

"The success of sustainable agriculture is dispelling the myth that modern techno-farming is the most productive method," says Miguel Altieri of the University of California, Berkeley. "In Mexico, it takes 1.73 hectares of land planted with maize to produce as much food as one hectare planted with a mixture of maize, squash and beans. The difference," he says, "comes from the reduction of losses due to weeds, insects and diseases and a more efficient use of the available resources of water, light and nutrients. Monocultures breed pests and waste resources," he says.

Researchers from the Association Tefy Saina, a Madagascan group working for local farmers, were looking for ways to boost rice yields on small farms. They decided to make the best use of existing strains rather than track down a new breed of super-rice. Through trial and error, a new system was developed that raises typical rice yields from three to twelve tonnes per hectare. The trick is to transplant seedlings earlier and in smaller numbers so that more survive; to keep paddles unflooded for much of the growing period; and to help the plants grow using compost rather than chemical fertilisers. The idea has grown like wildfire, and 20,000 have adopted the idea in Madagascar alone.

Few countries have switched wholesale to sustainable agriculture. But Cuba has. The collapse of the Soviet Union in 1990 cut off cheap supplies of grain, tractors and agrochemicals. Pesticide use halved overnight, as did the calorie intake of its citizens. The cash-strapped country was forced to embrace Low-input farming or starve. "Today," says Fernando Funes of the Country's Pasture and Fodder Research institute, "teams of oxen replace the tractors, and farmers have adopted organic methods, mixing maize with beans and cassava and doubling yields in the process, helping average calorie intake per person rise back to pre-1990 levels."

Worldwide, one of the most widely adopted sustainable techniques has been to throw away the plough, the ultimate symbol of the farmer. Ploughing aerates the soil, helping rot weeds and crop residues. But it can also damage soil fertility and increase erosion. Now millions of Latin American farmers have decided it isn't worth the effort. A third of Argentina's farms no longer use the plough. Instead, they fight weeds by planting winter crops, such as black oats, or by spraying a biodegradable herbicide such as glyphosate. The farmers saw results in a short time - reduced costs, richer soils, bigger grain yields and increased income, says Lauro Bassi of EPAGRI, the agricultural research institute in Santa Catarina state, southern Brazil, which has been promoting the idea.

Zero-tillage also benefits the planet in general. Unploughed soils hang on to carbon that would otherwise escape into the air as carbon dioxide when organic matter rots. "A one-hectare field left unploughed can absorb up to a tonne of carbon every year," says Pretty, "making soils a vital element in preventing global warming."

Sustainable agriculture is no magic bullet for feeding the world. It is an approach rather than a blueprint. Small farms with low yields stand to gain the most and agribusiness the least. But it does offer an alternative for the millions of small farms that have plenty of hands to work the land, but not the skills or financial resources to adopt conventional mechanised farming.

### **Questions 27-30**

Complete the sentences below. Write NO MORE THAN THREE WORDS for each answer.

Scientists base their predictions about global warming on evidence from 27 .....

Two weather conditions which are likely to become more common as an indirect result of global warming are 28 ..... and .....

Once infectious disease has become established in an area, its 29 ..... can prove extremely difficult.

Mosquitoes can be effectively destroyed by 30 ..... and very high temperatures.

## PASSAGE 3

**Is Global Warming Harmful To Health?**

Today, few scientists doubt the atmosphere is warming. Most also agree that the rate of heating is accelerating and that the consequences of this temperature change could become increasingly disruptive. Even high school students can recite some projected outcomes: the oceans will warm, and glaciers will melt, causing sea levels to rise and salt water to inundate low-lying coasts. Yet less familiar effects could be equally detrimental. Notably, computer models indicate that global warming, and other climate alterations it induces, will expand the incidence and distribution of many serious medical disorders.

Intensifying Heating of the atmosphere can influence health through several routes. Most directly, it can generate more, stronger and hotter heat waves, which will become especially treacherous if the evenings fail to bring cooling relief. Global warming can also threaten human well-being profoundly, if somewhat less directly, by revising weather patterns - particularly by increasing the frequency and intensity of floods and droughts and by causing rapid swings in the weather. Aside from causing death by drowning or starvation, these disasters promote by various means the emergence, resurgence and spread of infectious disease. That prospect is deeply troubling, because infectious illness may kill fewer people in one fell swoop than a raging flood or an extended drought, but once it takes root in a community, it often defies eradication and can invade other areas.

**Mosquitoes Rule in The Heat**

Diseases relayed by mosquitoes - such as malaria, dengue fever, yellow fever and several kinds of encephalitis - are among those eliciting the greatest concern as the world warms. Mosquito-borne disorders are projected to become increasingly prevalent because their insect carriers, or "vectors", are very sensitive to meteorological conditions. Cold can be a friend to humans, because it limits mosquitoes to seasons and regions where temperatures stay above certain minimums. Winter freezing kills many eggs, larvae and adults outright.

Excessive heat kills insects as effectively as cold does. Nevertheless, within their survivable range of temperatures, mosquitoes proliferate faster and bite more as the air becomes warmer. At the same time, greater heat speeds the rate at which the pathogens inside them reproduce and mature. As whole areas heat up, then, mosquitoes could expand into formerly forbidden territories, bringing illness with them. Further, warmer nighttime and winter temperatures may enable them to cause more disease for longer periods in the areas they already inhabit.

The extra heat is not alone in encouraging a rise in mosquito-borne infection. Intensifying floods and droughts resulting from global warming can each trigger outbreaks by creating breeding grounds for insects whose desiccated eggs remain viable and hatch in still water. As floods recede, they leave puddles. In times of drought, streams can become stagnant pools, and people may put out containers to catch water; these pools and pots, too, can become incubators for new mosquitoes. And the insects can gain another boost if climate change or other processes (such as alterations of habitats by humans) reduce the populations of predators that normally keep mosquitoes in check.

**Opportunities like Sequential Extremes**

The increased climate variability accompanying warming will probably be more important than the rising heat itself in fuelling unwelcome outbreaks of certain vector-borne illnesses. For instance, warm winters followed by hot, dry summers (a pattern that could become all too familiar as the atmosphere heats up) favor the transmission of St Louis encephalitis and other infections that cycle among birds, urban mosquitoes and humans. This sequence seems to have abetted the surprise emergence of the West Nile virus in New York City in 2000. No one knows how this virus found its way into the US. But one reasonable explanation for its persistence and amplification here centers on the weather's effects on *Culex pipiens* mosquitoes, which accounted for the bulk of transmission. These urban dwellers typically lay their eggs in damp basements, gutters, sewers and polluted pools of water.



The interaction between the weather, the mosquitoes and the virus probably went something like this: the mild winter of 1998-99 enabled many of the mosquitoes to survive into the spring, which arrived early. Drought in spring and summer concentrated nourishing organic matter in their breeding areas and simultaneously killed off mosquito predators, such as lacewings and ladybugs, that would otherwise have helped limit mosquito populations. Drought would also have led birds to congregate more, as they shared fewer and smaller watering holes, many of which were shared, naturally, by mosquitoes.

Once mosquitoes acquired the virus, the July heat wave that accompanied the drought would speed up the viral maturation inside the insects. Consequently, as infected mosquitoes sought blood meals, they could spread the virus to birds at a rapid rate. As bird after bird became infected, so did more mosquitoes, which ultimately fanned out to infect human beings. Torrential rains towards the end of August provided new puddles for the breeding of *C. pipiens* and other mosquitoes, unleashing an added crop of potential virus carriers.

### Solutions

The health toll taken by global warming will depend to a large extent on the steps taken to prepare for the dangers. The ideal defensive strategy would have multiple components, including improved surveillance systems to spot the emergence or resurgence of infectious diseases; predicting when environmental conditions could become conducive to disease outbreaks; and limiting human activities that contribute to the heating or that exacerbate its effects.

### Questions 31-35

Do the following statements agree with information given in Reading Passage 3? Write:

- TRUE if the statement agrees with the information  
 FALSE if the statement contradicts the information  
 NOT GIVEN if there is no information

31. Mosquito eggs are capable of surviving dry conditions
32. Animals which feed on mosquitoes may be adversely affected by global warming
33. Mosquitoes are becoming increasingly resistant to standard drugs
34. Higher temperatures are likely to be the most important factor in encouraging diseases carried by mosquitoes.
35. The mosquitoes which transmit West Nile disease breed in rural areas.

### Questions 36-40

Complete the flow chart below. Write **NO MORE THAN THREE WORDS** from the passage for each answer.

### Weather and West Nile Virus

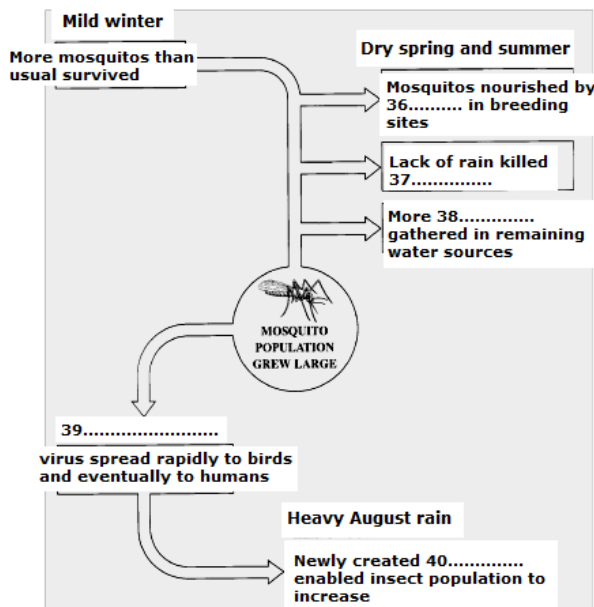

## Reading 13

## ACADEMIC READING FROM CAMBRIDGE VOCABULARY BOOK

**The causes, diagnosis and prevention of stress**

In prehistoric times, the physical changes in response to stress were an essential adaptation for meeting natural threats. Even in the modern world, the stress response can be an asset for raising levels of performance during critical events such as sports activities, important meetings, or in situations of actual danger or crisis. If stress becomes persistent and low-level, however, all parts of body's stress apparatus (the brain, heart, lungs, vessels and muscles) become chronically over or under activated. This may produce physical or psychological damage over time. Acute stress can also be harmful in certain situations.

**Psychological effects of stress**

Studies suggest that the inability to deal with stress is associated with the onset of depression or anxiety. In one study, two thirds of subjects who experienced a stressful situation had nearly six times the risk of developing depression within that month. Some evidence suggests that repeated release of stress hormones disrupts normal levels of serotonin, the nerve chemical that is critical for feelings of well being. Certainly, on a more obvious level, stress diminishes the quality of life by reducing the feelings of pleasure and accomplishment, and relationships are often threatened.

Nevertheless, some stress may be beneficial. For example, although some research has suggested that stress may be a risk factor for suicide (a 2003 study found a higher risk for suicide in women reporting both low and very high stress), those with moderate stress had the lowest risk.

**Heart disease**

The effects of mental stress on heart disease are controversial. Stress can certainly influence the activity of the heart when it activates the sympathetic nervous system (the automatic part of the nervous system that affects the nerve organs including the heart). Such actions and others could theoretically negatively affect the heart in several different ways.

Nevertheless, evidence is still needed to confirm any clear cut relation between stress and heart disease. For example, a 2002 study in Scotland found no greater risk for actual heart disease or heart events, although men with high stress levels did tend to complain of chest pain and go to hospital for it more often than those with lower stress levels.

Evidence has linked stress to heart disease in men particularly in work situations where they lack control. The association between stress and heart problems in women is weaker and there is some evidence that the ways women cope with stress may be more heart protective. In one study, for example, men were more apt than women to use alcohol or eat less healthy in response to stress than women, which might account for their higher heart risks from stress. Different stress factors may affect genders differently. In one study, work stress was associated with a higher risk of heart disease in men, but marital stress – not work stress – was associated with more severe heart disease in women with existing heart problems.

**Eating problems**

Stress can have varying effects on eating problems and weight. Often stress is related to weight gain and obesity. Many people develop cravings for salt, fat and sugar to counteract tension and, thus, gain weight. Weight gain can occur even with a healthy diet in some people exposed to stress. In a 2000 study, lean women who gained weight in response to stress tended to be less able to adapt to and manage stressful conditions. The release of cortisol, a major stress hormone, appears to promote abdominal fat and may be the primary connection between stress and weight gain in such people.

In contrast some people suffer a loss of appetite and consequently lose weight. In rare cases, stress may trigger hyperactivity of the thyroid gland, stimulating appetite but causing the body to burn up calories at a faster than normal rate. Chronically elevated levels of stress chemicals have been observed in patients with anorexia and bulimia. Some studies, however, have not found any strong link between stress and eating disorders.

**Pain**

Chronic pain caused by arthritis and other conditions may be intensified by stress. However, according to a study on patients with rheumatoid arthritis, stress management techniques do not appear to have much effect on arthritic pain. Some studies have clearly linked job dissatisfaction and depression to back pain, although it is still unclear if stress is a direct cause.

Tension type headaches are frequently associated with stress and stressful events. Some research suggests that headache sufferers may actually have some biological predisposition for translating stress into muscle contractions.

#### Sleep disturbances

The tensions of unresolved stress frequently cause insomnia, generally keep the unstressed person awake or causing awakening in the middle of the night or early morning. In fact evidence suggests that stress hormones can increase during sleep in anticipation of a specific waking time. However, there is some hope for sufferers in this area as relaxation therapy has been found to reduce stress levels and consequently improve the quality of sleep.

#### Questions 1-4

Do the following statements agree with the information given in the passage. *Write*

**TRUE** if the statement agrees with the information

**FALSE** if the statement contradicts the information

**NOT GIVEN** if there is no information on this

1. Stress was originally an important way of keeping humans safe.
2. If stress continues for a long time, all the body's organs are affected.
3. The study into the psychological effects of stress involved people with a history of depression.
4. Increased stress causes the body to produce more serotonin.

#### Questions 5-6

Choose the correct Answer A, B, C or D

5. The 2003 study into the link between stress and suicide found that
  - A. Fewer women suffer from stress than men
  - B. Stress reduces the risk of suicide in some women
  - C. A larger number of men commit suicide than women
  - D. Women with low stress levels are less likely to commit suicide.
6. In 2003, a Scottish study showed that
  - A. There is a strong link between stress and heart problems
  - B. There is a link between high stress levels and hospital visits
  - C. A reduction in stress would reduce the risk of heart attacks
  - D. Men with high levels of stress felt no physical symptoms

#### Questions 7-9

Classify the following characteristics as being associated with

- A. Only men
- B. Only women
- C. Both men and women

Write the correct letter A, B or C next to questions 7-9

7. There may be a variety of causes of stress
8. Their way of dealing with stress can protect the heart
9. Increased heart disease is linked to stress at home

#### Questions 10-13

Classify the following characteristics as being associated with

- A. Pain
- B. Weight
- C. Sleep

Write the correct letter A, B or C next to questions 10-13

10. The problem is reduced if stress is lowered
11. An increase in the severity of this problem may be related to work
12. Stress may cause levels to increase or decrease
13. This problem may be the result of the body's natural reaction to stress

**PASSAGE 2**

America is abuzz with talk of replacing imported oil with 'biofuels' produced from homogenous materials. The U.S Environmental Protection Agency recently honored famous country and western singer Willie Nelson for his efforts to promote the use of biodiesel through his own 'BioWillie' brand, a vegetable oil- based fuel which is now being distributed at filling stations nationally. Clearly, many hurdles stand in the way of making such biofuels commercially viable with traditional sources. Indeed, it remains very difficult to forecast whether powering our vehicles with crop derivatives will ever be a truly economic proposition. Nevertheless, it is not too early to ponder what impact the widespread adoption of biofuels would have on our environment.

Michael S. Briggs, a biodiesel advocate at the University of New Hampshire, has estimated that the United States would need about 140 billion gallons of biodiesel each year to replace all the petroleum-based transportation fuels currently being used. This calculation is premised on the idea that Americans could, over time, switch to using diesel vehicles, as European drivers are clearly doing- half of the new cars sold there now run on standard diesel. Although one could make a similar appraisal for the amount of sugar- derived ethanol needed to meet our needs, it is unlikely that drivers would ever want to fill up their tanks entirely with ethanol, which contains only two-thirds of the energy of gasoline, whereas biodiesel is only 2 % less fuel- efficient than petroleum- based diesel. Hence a switch to biofuels would demand no new technology and would not significantly reduce the driving range of a car or truck.

The main source of biodiesel is plant oil derivative from crops such as rapeseed. An acre of rapeseed could provide about 100 gallons of biodiesel per year. To fuel America in this way would require 1.4 billion acres of rapeseed fields. This number is a sizable fraction of the total US land area ( 2.4 billion acres) and considerably more than the 400 million acres currently under cultivation. Consequently, the burden on freshwater supplies and the general disruption that would accompany such a switch in fuel sources would be immense.

Such calculations are sobering. They suggest that weaning ourselves off petroleum fuels and growing rapeseed instead would be an environmental catastrophe. Are more productive oil crops the answer? Oil palms currently top the list because they can provide enough oil to produce about 500 gallons of biodiesel per acre per year, which reduces the land requirement fivefold. Yet its cultivation demands a tropical climate, and its large-scale production, which currently comes from such countries as Malaysia and Indonesia, is a significant factor in the ongoing destruction of what rainforest remains there. Conservationists have been warning that palm oil production poses a dire threat to the dwindling population of orangutans, for example, which exist only in the wild in Borneo and Sumatra. So here again, the prospect of dedicating sufficient land to growing feedstock for the world's transportation needs promises to be an environmental nightmare.

There is, however, a "crop" that is widely recognized as having the potential to meet the demands of a biodiesel-based transportation fleet without devastating the natural landscape: algae. Algae is a single- celled plant, some varieties of which can contain 50 percent or more oil. They also grow more rapidly than ordinary plants and can double in quantity within several hours.

The US Department of Energy funded considerable research on biofuel production using algae after the oil problems of the 1970s, an effort known as the Aquatic Species Program. Although this programme was terminated in the 1990s, a lot of experience was gained through research and various demonstration projects. The results suggested that algae can be grown in sufficient density to produce several thousand gallons of biodiesel per acre per year - a full order of magnitude better than can be expected using palm oil and two orders of magnitude better than soybeans.

It is not surprising then that many scientists and entrepreneurs are once again looking hard at the prospects for using algae to produce transportation fuels and sizeable amounts of money are being invested in various schemes for doing so. David Bayless, a professor of mechanical engineering at Ohio University, has been working with scientists to engineer a device that can

grow cyanobacteria (blue-green). It uses carbon dioxide from the gases emitted from power-plant chimneys and sunlight that is distributed to the growing surfaces through optical fibres. Bayless uses an enclosed bioreactor and claims to be able to produce as much as 60 grams of biomass per square metre of growing surface per day.

Another recent effort is being carried out in San Diego by KentSeaTech Corporation. This company gained experience growing algae as a part of its aquaculture operations so was quick to respond when the California state government started looking for ways to treat the huge quantities of nutrient-laden water which runs off from adjacent farm lands. It's no real difficult feat to turn nutrients into algae," says director of research Jon Van Oist, " but how do you it out of the water?" This is what Van Oist and his co-workers have been trying to achieve.

The people working on those ventures are clearly eager to make growing algae a commercial success. Yet it is not hard to find experts who view such prospects as dim indeed. John Benemann, a private consultant in California, has decades of experience in this area. He is particularly skeptical about attempts to make algae production more economical by using enclosed bioreactors rather than open ponds. He points out that Japan spent hundreds of millions of dollars on such research, which never went anywhere. Even Van Olst has serious reservations. 'It may work,' he says, 'but it is going to take a while and a lot of research before we get anywhere.'

#### Questions 14-18

Classify the following characteristics as belonging to

- A biodiesel
- B ethanol
- C ordinary diesel

Write the correct answers A-C next to questions 1-5

14. Produced by a popular American entertainer.....
15. 50% of new cars in Europe use this fuel.....
16. Provides two thirds of the power of standard petrol.....
17. Your car's performance will be almost unchanged if you change to this fuel.....
18. Production can have a negative impact on water resources.....

#### Questions 19-25

Do the following statements agree with the claims of the writer in the reading passage? Next to questions 6-12 write

- |           |  |
|-----------|--|
| Yes       | if the statement agrees with the claims of the writer        |
| No        | if the statement contradicts the claims of the writer        |
| Not given | if it is impossible to say what the writer thinks about this |

19. 2% of Americans already use biodiesel.....
20. At present in America, 400 million acres of land are used for agriculture.....
21. The use of palm oil as a fuel source will require more land than using rapeseed oil...
22. Growing biodiesel crops has had a positive effect on local wildlife in some areas...
23. One advantage of algae is the speed with which it grows.....
24. David Bayless believes that algae can produce more energy than solar power.....
25. It is easy to grow algae using agricultural waste water.....

#### Question 26

Choose the correct answer A, B, C or D.

26. What is the main purpose of this article?
  - A) To improve that biofuels could totally replace petrol in America.
  - B) To examine the environmental impact of standard fuel sources.
  - C) To assess the advantages and disadvantages of different types of fuel.
  - D) To show that an international effort is required to solve the fuel crisis.

## PASSAGE 3

**Storytelling**

Dr Tom Sjoblom, University of Helsinki, explores the link between narratives and memories. Storytelling seems to be a fundamental feature of human existence. In a recent article, Paul Hernadi points out that storytelling and narratives are such widespread phenomenon that they could justifiably be included in a list of human universals (Hernadi, 2001). But our craving for narratives or stories, goes deeper than this. It is embedded in our mental images of whatever happens around us (Boyer, 2001). In other words, creating narratives is our way of connecting and interacting with our environment (Mink, 1978).

As a species, we humans appear to have a much more active attitude towards our environment than any other species. Our bodies and minds not only adapt to the surrounding world, but we actually shape and construct our environment to better suit our needs (Plotkin, 1983). From this perspective, culture is nothing more than an environment that we create ourselves. Culture is not something in opposition to nature. Instead it is a part of it; it is - in a way - nature modified to better suit the requirements of the human life form. Thus, culture and all aspects of it are basically products of natural selection and, more specifically, the evolution of the human mind (Boyer, 2001).

Between 60,000 and 20,000 years ago the first sign of art and religion appeared and humans started to build houses and invent more sophisticated tools and weapons, such as bows and arrows. This period has been called the 'big bang' of human culture. There is still much controversy on how to explain this period of innovation, but a growing consensus connects the greater cultural energy and innovation of the period to the emergence of individuals as creative beings (Mellars, 1994)

The archaeologist Steven Miller has suggested that this creativity can be explained by the emergence of a 'cognitively fluid' mentality. In other words, the ability to link together information from different areas of our life. Cognitive fluidity makes it possible for human beings to emerge from the concrete situational present and to adopt a more general and abstract approach (Mithen, 1996). As Gerald Eldeman puts it, 'With that ability come the abilities to model the world, to make explicit comparisons and to weigh outcomes; through such comparisons comes the ability of reorganising plans.' (Eldeman, 1992)

Eldeman goes further than this and argues that it is the flexibility of our memory system which is the key to understanding how cognitive fluidity affects our ability to learn new things in general (Eldeman, 1992). The basic idea here is that our memory does not really represent the past as it happened. In most of the cases, it does not even represent it as it is stored and coded into our brains. Instead, our memory prefers creating the past from the perspective of how relevant it is to our present situation. Striving for this kind of coherence, our mind combines stored representations and blends information stored in them (Holyoak and Thagard, 1995). Thus, all things being equal, we do not remember the past, we create it.

The medieval art of memory, known as *memoria*, has interested historians for a long time, but seldom from a psychological or cognitive perspective. Recently, this has been changed by the work of Mary Carruthers. According to Carruthers, *memoria* was the reason why literature, in its fundamental sense existed in medieval Europe. It was the process by which a work of literature became both institutionalised by the group and learned by its individual members (Carruthers, 1990)

For those medieval experts who were educated in the art of memory there were two principal strategies for achieving their goal. The first and older of these strategies, attributed to Aristotle, relied on the concept of 'mental images'. Supporters of this strategy argued that

remembering was to see mental pictures, which are firmly imprinted upon the memory. Thus the best way to memorise narratives is to stimulate the act of memorising by using visual aids such as emotion-provoking representations, or so-called 'word pictures'. Descriptive language can also be used to create a kind of mental painting, although no actual pictures are present (Carruthers, 1990). As Albertus Magnus (1193-1280) puts it: 'something is not secure enough by hearing, but it is made firm by seeing' (Albertus I. 1. II. 6-7)

The second, and more popular, strategy for memorising narratives was rote learning. This was achieved by the frequent repetition of a text until it was accurately memorised. In this case, the process of memorising was aided by the use of rhythmic and/or formulaic expressions, and by breaking longer texts into numbered segments and then memorising them one by one (Carruthers, 1990).

The followers of this strategy criticised the use of visual imagery because of its inaccuracy. It was argued that the use of visual aids was marginally helpful at best, providing cues for recollection, but could not in itself guarantee the accuracy of the memorising process (Carruthers, 1990). The latter countered the criticism by arguing that, while in ordinary circumstances the accuracy of visual imagery could not be trusted, this problem would disappear if the visual imagery was strong enough to make a person emotionally engaged with the text. Indeed, they argued, it is the creation of strong emotional responses that makes the use of visual images such a powerful tool for memory creation (Carruthers, 1990).

#### Questions 27-34

Look at the following theories and the list of people below. Match each person with the correct theory. Write the correct letter (A-H) next to the questions 27-34

27. Early European storytelling came about because of a traditional form of memorising...
28. Cognitive fluidity allowed early humans to make and change arrangements
29. Telling stories allows us to relate to our surroundings
30. The brain changes our recollections of past events to match our current circumstances
31. Telling stories is a trait which is common to all nations
32. Early humans became more inventive when they were able to make a connection between different ideas
33. Your memory of something will be improved if you visualise it rather than just listen to it
34. Humans adjust to their surroundings as well as changing them

#### List of people

A. Hernadi	B. Mink	C. Plotkin	D. Mithen
E. Edelman	F. Holyoak and Thagard	G. Carruthers	H. Albertus

#### Questions 35-38

Complete each sentence with the correct ending A-F from the box.

35. Those who memorised using Aristotle's theory were helped by .....
36. The experts who used rote learning were helped by....
37. Those who supported rote learning believed that .....
38. Supporters of Aristotle's method of memorising believed that.....

- |   |
|---|
| <p>A. ....writing down their stories</p> <p>B. ....using paintings aided the memory</p> <p>C. ....visual aids were of limited help when memorising text</p> <p>D. ....if images evoked a passionate response then the memory would be more accurate</p> <p>E. ....creating a vivid image in their mind</p> <p>F. ....turning a long text into a series of short parts</p> |
|---|

Reading 14                      **READING COMPILED FROM CAMBRIDGE VOCABULARY – 2**

## **Practical intelligence lends a hand**

*Dr Rajendra Persaud explains how practical intelligence is linked to success.*

This year, record numbers of high school students obtained top grades in their final exams, yet employers complain that young people still lack the basic skills to succeed at work. The only explanation offered is that exams must be getting easier. But the real answer could lie in a study just published by Professor Robert Sternberg, an eminent psychologist at Yale University in the USA and the world's leading expert on intelligence. His research reveals the existence of a totally new variety: practical intelligence.

Professor Sternberg's astonishing finding is that practical intelligence, which predicts success in real life, has an inverse relationship with academic intelligence. In other words, the more practically intelligent you are, the less likely you are to succeed at school or university. Similarly, the more paper qualifications you hold and the higher your grades, the less able you are to cope with problems of everyday life and the lower your score in practical intelligence.

Many people who are clearly successful in their place of work do badly in standard 10 (academic intelligence) tests. Entrepreneurs and those who have built large businesses from scratch are frequently discovered to be high school or college drop-outs. IQ as a concept is more than 100 years old. It was supposed to explain why some people excelled at a wide variety of intellectual tasks. But IQ ran into trouble when it became apparent that some high scorers failed to achieve in real life what was predicted by their tests.

Emotional intelligence (EQ), which emerged a decade ago, was supposed to explain this deficit. It suggested that to succeed in real life, people needed both emotional as well as intellectual skills. EQ includes the abilities to motivate yourself and persist in the face of frustrations; to control impulses and delay gratification; to regulate moods and keep distress from swamping the ability to think; and to understand and empathize with others. While social or emotional intelligence was a useful concept in explaining many of the real-world deficiencies of super intelligent people, it did not go any further than the IQ test in measuring success in real life. Again, some of the most successful people in the business world were obviously lacking in social charm.

Not all the real-life difficulties we face are solvable with just good social skills - and good social acumen in one situation may not translate to another. The crucial problem with academic and emotional intelligence scores is that they are both poor predictors of success in real life. For example, research has shown that IQ tests predict only between 4% and 25% of success in life, such as job performance.

Professor Sternberg's group at Yale began from a very different position to traditional researchers into intelligence. Instead of asking what intelligence was and investigating whether it predicted success in life, Professor Sternberg asked what distinguished people who were thriving from those that were not. Instead of measuring this form of intelligence with mathematical or verbal tests, practical intelligence is scored by answers to real-life dilemmas such as: 'If you were travelling by car and got stranded on a motorway during a blizzard, what would you do?' An important contrast between these questions is that in academic tests there is usually only one answer, whereas in practical intelligence tests - as in real life - there are several different solutions to the problem.

The Yale group found that most of the really useful knowledge which successful people have acquired is gained during everyday activities - but typically without conscious awareness. Although successful people's behaviour reflects the fact that they have this knowledge, high achievers are often unable to articulate or define what they know. This partly explains why practical intelligence has been so difficult to identify.



Professor Sternberg found that the best way to reach practical intelligence is to ask successful people to relate examples of crucial incidents at work where they solved problems demonstrating skills they had learnt while doing their jobs. It would appear that one of the best ways of improving your practical intelligence is to observe master practitioners at work and, in particular, to focus on the skills they have acquired while doing the job. Oddly enough, this is the basis of traditional apprentice training. Historically, the junior doctor learnt by observing the consultant surgeon at work and the junior lawyer by assisting the senior barrister.

Another area where practical intelligence appears to resolve a previously unexplained paradox is that performance in academic tests usually declines after formal education ends. Yet most older adults contend that their ability to solve practical problems increases over the years. The key implication for organizations and companies is that practical intelligence may not be detectable by conventional auditing and performance measuring procedures. Training new or less capable employees to become more practically intelligent will involve learning from the genuinely practically intelligent rather than from training manuals or courses.

Perhaps the biggest challenge is in recruitment, as these new studies strongly suggest that paper qualifications are unlikely to be helpful in predicting who will be best at solving your company's problems. Professor Sternberg's research suggests that we should start looking at companies in a completely different way - and see them as places where a huge number of problems are being solved all the time but where it may take new eyes to see the practical intelligence in action.

**Questions 1-5** Choose the correct answer, A, B, C or D.

1. Professor Sternberg's study showed that
  - A. qualifications are a good indicator of success at work.
  - B. education can help people cope with real-life problems.
  - C. intelligent people do not always achieve well at school.
  - D. high grades can indicate a lack of practical intelligence.
2. What is the 'deficit' referred to in the fourth paragraph?
  - A. People with high IQ scores could not score well in EQ tests.
  - B. EQ tests were unable to predict success at work.
  - C. High IQ scores did not always lead to personal success.
  - D. People with high EQ scores could not cope with real life.
3. Professor Sternberg's research differed from previous studies because
  - A. he used verbal testing instead of mathematics.
  - B. he began by establishing a definition of intelligence.
  - C. he analyzed whether intelligence could predict success in real life.
  - D. he wanted to find out what was different about successful people.
4. Part of the reason why practical intelligence had not been identified before Professor Sternberg's study is that
  - A. the behaviour of successful people had never been studied.
  - B. successful people are too busy with their everyday lives.
  - C. successful people cannot put their knowledge into words.
  - D. successful people are unaware of their own abilities.
5. In order to increase the practical intelligence of employees, companies need to
  - A. adopt an apprentice-style system.
  - B. organise special courses.
  - C. devise better training manuals.
  - D. carry out an audit on all employees.

**Questions 6-12** Classify the following characteristics as belonging to

- A. academic intelligence (IQ) tests
  - B. emotional intelligence (EQ) tests
  - C. practical intelligence tests
6. measures skills which are likely to improve with age
  7. assesses people's social skills
  8. measures the ability to deal with real-life difficulties
  9. the oldest of the three tests
  10. high scorers learn from their actions
  11. high scorers are more likely to stay calm in difficult situations
  12. questions have more than one possible answer

## PASSAGE 2

**How consumers decide**

*Professor John Maule from the University of Leeds describes new research into the way that consumers choose a product.*

**Understanding consumers**

Consumers are creatures of habit: they buy the same products time and time again, and such is their familiarity with big brands, and the colours and logos that represent them, that they can register a brand they like with barely any conscious thought process. The packaging of consumer products is therefore a crucial vehicle for delivering the brand and the product into our shopping baskets.

Having said this, understanding how consumers make decisions, and the crucial role of packaging in this process, has been a neglected area of research so far. This is surprising given that organisations invest huge amounts of money in developing packaging that they believe is effective – especially at the retail level. Our Centre for Decision Research at Leeds University's Business School, in collaboration with Faraday Packaging, is now undertaking work in this area. It has already led to some important findings that challenge the ways in which organisations think about consumer choice.

The research has focused on two fundamental types of thinking. On the one hand, there's 'heuristic processing', which involves very shallow thought and is based on very simple rules: 1) buy what you recognize, 2) choose what you did last time, or 3) choose what a trusted source suggests. This requires comparatively little effort, and involves looking at – and thinking about – only a small amount of the product information and packaging. One can do this with little or no conscious thought.

On the other hand, 'systematic processing' involves much deeper levels of thought. When people choose goods in this way, they engage in quite detailed analytical thinking – taking account of the product information, including its price, its perceived quality and so on. This form of thinking, which is both analytical and conscious, involves much more mental effort. The role of packaging is likely to be very different for each of these types of decision making. Under heuristic processing, for example consumers may simply need to be able to distinguish the pack from those of competitors since they are choosing on the basis of what they usually do. Under these circumstances, the simple perceptual features of the pack may be critical – so that we can quickly discriminate what we choose from the other products on offer. Under systematic processing, however, product-related information may be more important, so the pack has to provide this in an easily identifiable form.

**Comparing competition**

Consumers will want to be able to compare the product with its competitors, so that they can determine which option is better for them. A crucial role of packaging in this situation is to communicate the characteristics of the product, highlighting its advantages over possible competitors.

So, when are people likely to use a particular type of thinking? First, we know that people are cognitive misers; in other words they are economical with their thinking because it requires some effort from them. Essentially, people only engage in effort-demanding systematic processing when the situation justifies it, for example when they are not tired or distracted and when the purchase is important to them.

Second, people have an upper limit to the amount of information they can absorb. If we present too much, therefore, they will become confused. This, in turn, is likely to lead them to disengage and choose something else.

Third, people often lack the knowledge or experience needed, so will not be able to deal with things they do not already understand, such as the ingredients of food products, for example. And fourth, people vary in the extent to which they enjoy thinking. Our research has differentiated between people with a high need for thinking – who routinely engage in analytical thinking – and those low in the need for cognition, who prefer to use very simple forms of thinking.

**Effectiveness varies**

This work has an important impact on packaging in that what makes packaging effective is likely to vary according to the type of processing strategy that consumers use when choosing between products. You need to understand how consumers are selecting your products if you are to develop packaging that is relevant. Furthermore, testing the effectiveness of your packaging can be ineffective if the methods you are employing concern one form of thinking (e.g. a focus group involving analytical thinking) but your consumers are purchasing in the other mode (i.e. the heuristic, shallow form of thinking).

For the packaging industry it is important that retailers identify their key goals. Sustaining a consumer's commitment to a product may involve packaging that is distinctive at the heuristic level (if the consumers can recognize the product they will buy it) but without encouraging consumers to engage in systematic processing (prompting deeper level thinking that would include making comparisons with other products).

Conversely, getting consumers to change brands may involve developing packaging that includes information that does stimulate systematic processing and thus encourages consumers to challenge their usual choice of product. Our work is investigating these issues, and the implications they have for developing effective packaging.

**Questions 13-18**

Next to Questions 13-18 write

<b>TRUE</b>	if the statement agrees with the information
<b>FALSE</b>	if the statement contradicts the information
<b>NOT GIVEN</b>	if there is no information on this

13. Little research has been done on the link between packaging and consumers choosing product.
14. A person who buys what another person recommends is using heuristic thinking.
15. Heuristic processing requires more energy than systematic processing.
16. The concept of heuristic processing was thought up by Dr Maule's team.
17. A consumer who considers how much a product costs is using systematic processing.
18. For heuristic processing, packaging must be similar to other products.

**Questions 19-20**

Choose the correct answer A, B, C or D.

19. When trying to determine how effective packaging is, testing can be made 'ineffective' .
  - A. you rely upon a very narrow focus group.
  - B. your consumers use only heuristic thinking.
  - C. the chosen consumers use only shallow thinking.
  - D. your tests do not match the consumers' thinking type.
20. If a retailer wants consumers to change brands their packaging needs to be
  - A. informative.
  - B. distinctive.
  - C. familiar.
  - D. colourful.

**Questions 21-25** Complete the summary below.

**Write NO MORE THAN TWO WORDS for each answer.**

**Comparing competition**

For consumers who want to compare products it is important that your packaging stresses the 21.....of your product.

We know that people only use systematic processing if the 2..... makes it necessary or desirable. We also know that too much 23..... could make consumers choose another product. Furthermore, consumers may not fully understand details such as the 24.....of a product. While some people like using systematic processing, others like to think in a 5..... way.

## PASSAGE 3

**Endangered chocolate**

- A. The cacao tree, once native to the equatorial American forest, has some exotic traits for a plant. Slender and shrubby, the cacao has adapted to life close to the leaf littered forest floor. Its large leaves droop down, away from the sun. Cacao doesn't flower, as most plants do, at the tips of its outer and uppermost branches. Instead, its sweet white buds hang from the trunk and along a few fat branches which form where leaves drop off. These tiny flowers transform into pulp-filled pods almost the size of rugby balls. The low-hanging pods contain the bitter-tasting, magical seeds.
- B. Somehow, more than 2,000 years ago, ancient humans in Mesoamerica discovered the secret of these beans. If you scoop them from the pod with their pulp, let them ferment and dry in the sun, then roast them over a gentle fire, something extraordinary happens: they become chocolatey. And if you then grind and press the beans, which are half cocoa butter or more, you will obtain a rich, crumbly, chestnut brown paste - chocolate at its most pure and simple.
- C. The Maya and Aztecs revered this chocolate, which they frothed up with water and spices to make bracing concoctions. It was edible treasure, offered up to their gods, used as money and hoarded like gold. Long after Spanish explorers introduced the beverage to Europe in the sixteenth century, chocolate retained an aura of aristocratic luxury. In 1753, the Swedish botanist Carolus Linnaeus gave the cacao tree genus the name *Theobroma*, which means 'food of the gods'
- D. In the last 200 years the bean has been thoroughly democratized - transformed from an elite drink into ubiquitous candy bars, cocoa powders and confections. Today chocolate is becoming more popular worldwide, with new markets opening up in Eastern Europe and Asia. This is both good news and bad because, although farmers are producing record numbers of cacao bean, this is not enough, some researchers worry, to keep pace with global demand. Cacao: also facing some alarming problems.
- E. Philippe Petithuguenin, head of the cacao program at the Centre for International Cooperation in Development-Oriented Agricultural Research (CIRAD) in France, recently addressed a seminar in the Dominican Republic. He displayed a map of the world revealing a narrow band within 18° north and south of the equator, where cacao grows. In the four centuries since the Spanish First happened upon cacao, it has been planted all around this hot humid tropical belt - From South America and the Caribbean to West Africa, east Asia, and New Guinea and Vanuatu in the Pacific.
- F. Today 70% of all chocolate beans come from West Africa and Central Africa. In many parts, growers practise so-called pioneer Farming. They strip patches of Forest of all but the tallest canopy trees and then they put in cacao, using temporary plantings of banana to shade the cacao while it's young. With luck, groves like this may produce annual yields of 50 to 60 pods per tree for 25 to 30 years. But eventually pests, pathogens and soil exhaustion take their toll and yields diminish. Then the growers move on and clear a new Forest patch - unless farmers of other crops get there first. 'You cannot keep cutting tropical Forest, because the Forest itself is endangered,' said Petithuguenin. 'World demand for chocolate increases by 3% a year on average. With a lack of land for new plantings in tropical Forests, how do you meet that?'
- G. Many Farmers have a more imminent worry: outrunning disease. Cacao, especially when grown in plantations, is at the mercy of many afflictions, mostly rotting diseases caused by various species of Fungi, which cover the pods in fungus or kill the trees. These fungi and other diseases spoil more than a quarter of the world's yearly harvest and can devastate entire cacao-growing regions.
- H. One such disease, witches broom, devastated the cacao plantations in the Bahia region of Brazil. Brazil was the third largest producer of cacao beans but in the 1980s the yields fell by 75%. According to Petithuguenin, 'if a truly devastating disease like witches broom reached West Africa (the world's largest producer), it could be catastrophic.' If another producer had the misfortune to falter now, the ripples would be felt the world over. In the United States, for example, imported cacao is the linchpin of an \$8.6 billion domestic chocolate industry that in turn supports the nation's dairy and nut industries; 20% of all dairy products in the US go into confectionery

- I. Today research is being carried out to try to address this problem by establishing disease resistant plants. However, even the best plants are useless if there isn't anywhere to grow them. Typically, farmers who grow cacao get a pittance for their beans compared with the profits reaped by the rest of the chocolate business. Most are at the mercy of local middlemen who buy the beans then sell them for a much higher price to the chocolate manufacturers. IF the situation is to improve For Farmers, these people need to be removed from the process. But the economics of cacao is rapidly changing because of the diminishing supply of beans. Some companies have realised that they need to work more closely with the Farmers to ensure that sustainable farming practices are used. They need to replant areas and create a buffer For the Forest, to have ground cover, shrubs and small trees as well as the canopy trees. Then the soil will be more robust and more productive. They also need to empower the farmers by guaranteeing them a higher price For their beans so that they will be encouraged to grow cacao and can maintain their way of life.

**Questions 26-28** Choose the correct letter, A, B, C or D.

26. The flowers of the cacao plant appear  
 A. at the end of its top branches.  
 B. along all of its branches.  
 C. mainly on its trunk.  
 D. close to its leaves.
27. In Africa, banana trees are planted with the cacao plants in order to  
 A. replace the largest trees.  
 B. protect the new plants.  
 C. provide an extra crop.  
 D. help improve soil quality.
28. In paragraph H, what is the writer referring to when he says 'the ripples would be felt the world over'?  
 A. the impact a collapse in chocolate production could have on other industries  
 B. the possibility of disease spreading to other crops  
 C. the effects of the economy on world chocolate growers  
 D. the link between Brazilian growers and African growers

**Questions 29-34**

The Reading Passage has nine paragraphs labelled A-I. Which paragraph contains the following information? Write the correct letter A-I next to Questions 29-34 below.

29. a list of the cacao growing areas  
 30. an example of how disease has affected one cacao growing region  
 31. details of an ancient chocolate drink  
 32. a brief summary of how the chocolate industry has changed in modern times  
 33. the typical lifespan and crop size of a cacao plantation  
 34. a reference to the scientific identification of the cacao plant

**Questions 35-38** Complete the notes below.

Write NO MORE THAN TWO WORDS from the passage for each answer.

Write your answers in spaces 35-38 below.

Ways of dealing with the cacao plant's problems

Need to find plants which are not affected by 35.....

Chocolate producers need to work directly with farmers instead of 6.....

Need to encourage farmers to use 37.....methods to grow cacao plants

Make sure farmers receive some of the 38.....made by the chocolate industry

Help Now Reading TEST 1

READING PASSAGE 1

Questions 1 - 13

## **THE BIG CATS AT THE SHARJAH BREEDING CENTRE**

It is one of the few places where you will be able to spot them all at the same time... the Arabian wolf, an African cheetah, an Arabian leopard, an oryx, a gazelle. These are just some of the animals, which, on the brink of extinction, are now getting a new lease of life thanks to the exemplary work being done at the Breeding Centre for Endangered Arabian Wildlife in Sharjah.

Sharjah is one of the seven emirates that make up the United Arab Emirates. The Breeding Centre's expertise and facilities have made it a prime destination for illegally imported animals confiscated by UAE and Sharjah authorities. In the last four years, more than 900 mammals and reptiles and 969 birds have arrived at the centre, including 25 North African cheetahs, Houbara bustard and falcons, lions, a baby Nile crocodile and a Burmese python that was left in a rental car at the airport.

The 25 cheetahs were all imported illegally into the UAE and were intercepted at the UAE harbour and airport entry points. They nearly all arrived malnourished, dehydrated and highly stressed after long voyages stuffed into boxes, crates and suitcases. Now they are bright and full of energy. The Centre's efforts have also been rewarded when the first cheetah mating took place at the end of 2002. Playing matchmaker with these beautiful creatures is no easy task – successful breeding requires considerable patience and intimate knowledge of each animal's personality, and it is the result of intensive and expert management of each animal within the group as well as of the group as a whole.

Because this group was still young and inexperienced in courtship matters, the keepers had to make the introductions only after careful planning and management, much like the lead role in a Jane Austen novel. The female cheetahs were initially intimidated by the presence of the male; however, as they advance to oestrus, the roles are reversed and the male cheetah becomes too wary to approach during the female's most receptive phase of the cycle. It is the responsibility of the keeper therefore to monitor each individual and to be able to respond to any indication from the cheetahs that the time is right for introducing a pair. The close bond that invariably develops between the keeper and the cheetahs enables the keeper to spot even the most subtle signs from the animals in their care. The trust between keeper and animal has also allowed the opportunity to study cellular changes in the sexual organs of the females during the hormonal cycles that occur prior to reproduction.

The Breeding Centre's cheetahs are also participants in the European breeding programme, which aims to ensure that the genetic diversity of this endangered species is maintained and expanded by breeding as many founder animals as possible to introduce new bloodlines into the captive population. In this way, the group held at the centre plays a very important role in the future health of the international captive population, as they are potentially all new founders.

Also very important for the Sharjah Breeding Centre is the leopard-breeding programme. The Arabian leopard, *Panthera pardus nimr*, is critically endangered around the world and particularly in the Arabian peninsula, where it was once found throughout the coastal mountain ranges. Activities like hunting, trapping and habitat destruction has reduced their range to a few isolated and fragmented populations in Oman, Yemen and Saudi Arabia.

In the 1980s, a captive breeding programme was established near Muscat with the capture of three leopards in southwestern Oman. The breeding programme in the UAE was initiated by the Arabian Leopard Trust and started with the arrival of two mature

specimens: a male Arabian leopard from Yemen and a female on breeding loan from Oman in 1995. The arrival of these two animals led to the construction of the Breeding Centre in which the leopard has played the role of flagship species.

Today there are twelve leopards at the Breeding centre, eight of which have been born at the centre since the first cub in 1998. Once more, the secret to the centre's success is the close relationship between animal and keeper. The leopard is usually shy and secretive with people around, but here they react positively to the presence of their keepers, approaching the fence so they can be talked to or scratched behind an ear.

The bond is particularly important during breeding season, when keepers decide to introduce pairs to each other. Male leopards are known to have killed their partners on introduction, so it is essential for the keeper to understand the leopards' behaviour to decide when it is safe to do so. The trust is also important if keepers need to enter dens to check on and monitor the cub's growth. Leopard females have been known to kill their cubs if the dens have been disturbed, but the centre's leopards are quite comfortable with the staff handling the new generation of cubs.

**Questions 1- 8**

Use the information in the text to match the statements (1 – 8) with the animals (A – D). Write

- A. If the statement refers to cheetahs at the Breeding Centre.
- B. If the statement refers to leopards at the Breeding Centre.
- C. If the statement refers to both cheetahs and leopards at the Breeding Centre.
- D. If the statement refers to neither cheetahs nor leopards at the Breeding Centre.

Example	These animals are endangered	Answer	C
---------	------------------------------	--------	---

1. These animals were smuggled into the UAE.
2. At first these animals did not adapt to life at the Sharjah Breeding Centre.
3. These animals are regarded as the most important animal at the Centre.
4. Half of these animals were born at the Breeding centre.
5. These animals can be dangerous to one another.
6. The role of the keeper is vital in the breeding programme of these animals.
7. The first of these animals at the Breeding Centre were relatively young.
8. It is normally difficult for humans to approach these animals.

**Questions 9 – 13**

Complete the summary below. Choose your answers from the box below the summary.

NB There are more words than spaces, so you will not use them all.

The Sharjah Breeding Centre now has a variety (Example) of animals including birds, mammals and 9..... As its name suggests, the Centre is primarily involved in breeding and 10.....the numbers of the species housed there whilst still maintaining the 11..... of bloodlines in order to retain genetic health. In spite of problems involving the complex 12.....of the animals, a fair amount of 13.....has been achieved with North African cheetahs and Arabian leopards.

reptiles	variety	behaviour	success	creating
expanding	difficulty	diversity	action	habitat
season	fish	change	working	programme

## READING PASSAGE 2

Questions 14 - 27

**INSOMNIA – THE ENEMY OF SLEEP****A**

It is not unusual to have sleep troubles from time to time. But, if you feel you do not get enough sleep or satisfying sleep, you may have insomnia, a sleep disorder. People with insomnia have one or more of the following: difficulty falling asleep, waking up often during the night and having trouble going back to sleep, waking up too early in the morning and unrefreshing sleep. Insomnia is not defined by the number of hours you sleep every night. The amount of sleep a person needs varies. While most people need between 7 and 8 hours of sleep a night, some people do well with less, and some need more.

**B**

Insomnia occurs most frequently in people over age 60, in people with a history of depression, and in women, especially after menopause. Severe emotional trauma can also cause insomnia with divorced, widowed and separated people being the most likely to suffer from this sleep disorder. Stress, anxiety, illness and other sleep disorders such as restless legs syndrome are the most common causes of insomnia. An irregular work schedule, jet lag or brain damage from a stroke or Alzheimer's disease can also cause insomnia as well as excessive use of alcohol or illicit drugs. It can also accompany a variety of mental illnesses.

**C**

The mechanism that induces sleep is not known. When it becomes dark, the pineal gland in the brain secretes a hormone called melatonin, which is thought to induce sleep. Exactly why sleep is necessary for good health and efficient mental functioning is unknown. We do know that sleep consists of two very different states: rapid eye movement (REM) sleep and non-REM sleep. In REM sleep, dreams occur, the eyes move under the closed lids and there is an increase in oxygen consumption, blood flow and neural activity. REM sleep occurs four or five times during a night. Beginning periods last about ten to fifteen minutes but the periods get longer as the night goes on. The periods of REM sleep alternate with longer periods of non-REM sleep, when body functions slow. Non-REM sleep has four stages. During the deepest stages (3 and 4) it is hard to rouse a sleeper. As the night goes on, the periods of non-REM sleep become progressively lighter. Sleep in stages 1 and 2 are felt to be restorative as during this time the body repairs itself utilizing a hormone called somatostatin. Lack of stage 4 sleep is believed to be important in chronically painful conditions such as fibromyalgia.

**D**

Healthcare providers diagnose insomnia in several ways. One way is to categorize insomnia by how often it occurs. Another way is to identify the insomnia by what is causing the sleep deprivation. The two main types of insomnia have been described as Primary Insomnia and Secondary Insomnia. Primary Insomnia is a chronic condition with little apparent association with stress or a medical problem. The most common form of primary insomnia is psychophysiological insomnia. Secondary insomnia is caused by symptoms that accompany a medical condition such as anxiety, depression or pain.

**E**

Improving one's sleep hygiene helps improve insomnia in all patients. Relaxing during the hour before you go to sleep and creating a comfortable environment suited for sleep can be helpful. Older people who wake up earlier than normal or have trouble falling asleep may need less sleep than they used to. Changing one's sleep pattern, either by going to bed later or waking up earlier, can be effective in dealing with insomnia in older people. Therapy also depends on the cause and severity of the insomnia. Transient and intermittent insomnia may not require any direct action since these conditions last only a few days at a time. However, if insomnia interferes with a person's daily activities, something should be done. Usually the best method of dealing with insomnia is by attacking the underlying cause. For example, people who are depressed often have insomnia and looking at this problem may eliminate it.



F

Not getting enough sleep can make you less productive, irritable and unable to concentrate. Lack of sleep can make it seem as if you “got up out of the wrong side of the bed.” Early morning headaches and waking up feeling as if you never went to sleep can result in frustration. Stress can cause insomnia but insomnia also increases stress. Insomnia can make driving unsafe as well. Insomnia can result in missed work, which can cause you to become less productive and miss promotions. It can leave you feeling as if you just can’t get enough done. Insomnia can also mask serious mental disorders. People with insomnia may think that not getting enough sleep is their only problem, but the insomnia may actually be one symptom of a larger disorder, such as depression. Studies show that people with insomnia are four times more likely to be depressed than people with a healthy sleeping pattern. In addition, lack of sleep can tax the heart and lead to serious conditions like heart disease. All of these are important problems that can affect every part of your life.

G

Establishing certain set routines can help insomniacs get better sleep. Examples of these routines include: going to bed and getting up at the same time every day, avoiding napping, avoiding caffeine, nicotine, alcohol and eating heavily late in the day, exercising regularly and making your bedroom comfortable in terms of the bed, noise and temperature. Insomniacs should also only use their bedroom for sleep so that their bodies associate the room with sleep. Finally, if you can’t get to sleep, don’t toss and turn all night. Get up and read or do something that is not overly stimulating until you feel really sleepy again.

#### Questions 14 - 19

The reading passage on Insomnia has 7 paragraphs (A – G). Choose the most suitable headings for paragraphs B – G. NB There are more headings than paragraphs, so you will not use them all.

*Example*      Paragraph A      *Answer*      iv

i.	The Role of Sleep
ii.	Insomnia Medication
iii.	Habits to Promote a Good Night’s Sleep
iv.	What is Insomnia
v.	Complications for Insomniacs
vi.	Government Action
vii.	Available Treatment for Insomnia
viii.	The Causes of Insomnia
ix.	Therapy Solutions
x.	Types of Insomnia
xi.	Current Research

- |                 |
|-----------------|
| 14. Paragraph B |
| 15. Paragraph C |
| 16. Paragraph D |
| 17. Paragraph E |
| 18. Paragraph F |
| 19. Paragraph G |

#### Questions 20 - 27

Do the following statements agree with the views of the writer of the reading passage on Insomnia? Write:

- YES                                      if the statement agrees with the writer  
 NO                                        if the statement doesn’t agree with the writer  
 NOT GIVEN                            if it is impossible to say what the writer thinks about this

20. Someone who only gets four hours of sleep a night must be suffering from insomnia.
21. Travelling can cause insomnia.
22. REM sleep is felt to be the most important for the body’s rest.
23. Secondary insomnia is far more common than primary insomnia.
24. Sufferers of insomnia can attend specialist sleep clinics.
25. Many people suffering from insomnia don’t realise that they suffer from it.
26. There is no actual correlation linking insomnia and depression.
27. Sleeping during the day can make insomnia worse.

## READING PASSAGE 3

Questions 28 - 40

**ALTERNATIVE FARMING METHODS IN OREGON**

Onion growers in eastern Oregon are adopting a system that saves water and keeps topsoil in place, while producing the highest quality “super colossal” onions. Pear growers in southern Oregon have reduced their use of some of the most toxic pesticides by up to two-thirds, and are still producing top-quality pears. Range managers throughout the state have controlled the poisonous weed tansy ragwort with insect predators and saved the Oregon livestock industry up to \$4.8 million a year.

These are some of the results Oregon growers have achieved in collaboration with Oregon State University (OSU) researchers as they test new farming methods including integrated pest management (IPM). Nationwide, however, IPM has not delivered results comparable to those in Oregon. A recent U.S. General Accounting Office (GAO) report indicates that while integrated pest management can result in dramatically reduced pesticide use, the federal government has been lacking in effectively promoting that goal and implementing IPM. Farmers also blame the government for not making the new options of pest management attractive. “Wholesale changes in the way that farmers control the pests on their farms is an expensive business.” Tony Brown, of the National Farmers Association says. “If the farmers are given tax breaks to offset the expenditure, then they would willingly accept the new practices.” The report goes on to note that even though the use of the riskiest pesticides has declined nationwide, they still make up more than 40 percent of all pesticides used today; and national pesticide use has risen by 40 million kilograms since 1992. “Our food supply remains the safest and highest quality on Earth but we continue to overdose our farmland with powerful and toxic pesticides and to under-use the safe and effective alternatives,” charged Patrick Leahy, who commissioned the report. Green action groups disagree about the safety issue. “There is no way that habitual consumption of foodstuffs grown using toxic chemicals of the nature found on today’s farms can be healthy for consumers,” noted Bill Bowler, spokesman for Green Action, one of many lobbyists interested in this issue.

The GAO report singles out Oregon’s apple and pear producers who have used the new IPM techniques with growing success. Although Oregon is clearly ahead of the nation, scientists at OSU are taking the Government Accounting Office criticisms seriously. “We must continue to develop effective alternative practices that will reduce environmental hazards and produce high quality products,” said Paul Jepson, a professor of entomology at OSU and new director of OSU’s Integrated Plant Protection Centre (IPPC). The IPPC brings together scientists from OSU’s Agricultural Experiment Station, OSU Extension service, the U.S. Department of Agriculture and Oregon farmers to help develop agricultural systems that will save water and soil, and reduce pesticides. In response to the GAO report, the Centre is putting even more emphasis on integrating research and farming practices to improve Oregon agriculture environmentally and economically.

“The GAO report criticizes agencies for not clearly communicating the goals of IPM,” said Jepson. “Our challenge is to greatly improve the communication to and from growers, to learn what works and what doesn’t. The work coming from OSU researchers must be adopted in the field and not simply languish in scientific journals.”

In Oregon, growers and scientists are working together to instigate new practices. For example, a few years ago scientists at OSU’s Malheur Experiment Station began testing a new drip irrigation system to replace old ditches that wasted water and washed soil and fertilizer into streams. The new system cut water and fertilizer use by half, kept topsoil in place and protected water quality. In addition, the new system produced crops of very large onions, rated “super colossal” and highly valued by the restaurant industry and food processors. Art Pimms, one of the researchers at Malheur comments: “Growers are finding

that when they adopt more environmentally benign practices, they can have excellent results. The new practices benefit the environment and give the growers their success.”

OSU researchers in Malheur next tested straw mulch and found that it successfully held soil in place and kept the ground moist with less irrigation. In addition, and unexpectedly, the scientists found that the mulched soil created a home for beneficial beetles and spiders that prey on onion thrips – a notorious pest in commercial onion fields – a discovery that could reduce the need for pesticides. “I would never have believed that we could replace the artificial pest controls that we had before and still keep our good results,” commented Steve Black, a commercial onion farmer in Oregon, “but instead we have actually surpassed expectations.”

OSU researchers throughout the state have been working to reduce dependence on broad-spectrum chemical sprays that are toxic to many kind of organisms, including humans. “Consumers are rightly putting more and more pressure on the industry to change its reliance on chemical pesticides, but they still want a picture-perfect product,” said Rick Hilton, entomologist at OSU’s Southern Oregon Research and Extension Centre, where researchers help pear growers reduce the need for highly toxic pesticides. Picture perfect pears are an important product in Oregon and traditionally they have required lots of chemicals. In recent years, the industry has faced stiff competition from overseas producers, so any new methods that growers adopt must make sense economically as well as environmentally. Hilton is testing a growth regulator that interferes with the molting of codling moth larvae. Another study used pheromone dispensers to disrupt codling moth mating. These and other methods of integrated pest management have allowed pear growers to reduce their use of organophosphates by two-thirds and reduce all other synthetic pesticides by even more and still produce top-quality pears. These and other studies around the state are part of the IPPC to find alternative farming practices that benefit both the economy and the environment.

Source: Peg Herring / Oregon State University

**Questions 28 – 35** Match the views (28 – 35) with the people listed below.

- 28. There is a double advantage to the new techniques.
- 29. Expectations of end users of agricultural products affect the products.
- 30. The work on developing these alternative techniques is not finished.
- 31. Eating food that has had chemicals used in its production is dangerous to our health.
- 32. Changing current farming methods is not a cheap process.
- 33. Results have exceeded anticipations.
- 34. The research done should be translated into practical projects.
- 35. The U.S. produces the best food in the world.

TB	Tony Brown
PL	Patrick Leahy
BB	Bill Bowler
PJ	Paul Jepson
AP	Art Pimms
SB	Steve Black
RH	Rick Hilton

**Questions 36 - 40**

- TRUE *if the statement is true*
- FALSE *if the statement is false*
- NOT GIVEN *if the information is not given in the advertisement*

- 36. Integrated Pest Management has generally been regarded as a success in the US.
- 37. Oregon farmers of apples and pears have been promoted as successful examples of Integrated Pest Management.
- 38. The IPPC uses scientists from different organisations.
- 39. Straw mulch experiments produced unplanned benefits.
- 40. The apple industry is now facing a lot of competition from abroad.

**Help Now Reading TEST 2****READING PASSAGE 1 Questions 1 - 14****DIABETES**

Here are some facts that you probably didn't know about diabetes. It is the world's fastest growing disease. It is Australia's 6th leading cause of death. Over 1 million Australians have it though 50% of those are as yet unaware. Every 10 minutes someone is diagnosed with diabetes. So much for the facts but what exactly is diabetes?

Diabetes is the name given to a group of different conditions in which there is too much glucose in the blood. Here's what happens: the body needs glucose as its main source of fuel or energy. The body makes glucose from foods containing carbohydrate such as vegetables containing carbohydrate (like potatoes or corn) and cereal foods (like bread, pasta and rice) as well as fruit and milk. Glucose is carried around the body in the blood and the glucose level is called glycaemia. Glycaemia (blood sugar levels) in humans and animals must be neither too high nor too low, but just right. The glucose running around in the blood stream now has to get out of the blood and into the body tissues. This is where insulin enters the story. Insulin is a hormone made by the pancreas, a gland sitting just below the stomach. Insulin opens the doors that let glucose go from the blood to the body cells where energy is made. This process is called glucose metabolism. In diabetes, the pancreas either cannot make insulin or the insulin it does make is not enough and cannot work properly. Without insulin doing its job, the glucose channels are shut. Glucose builds up in the blood leading to high blood glucose levels, which causes the health problems linked to diabetes.

People refer to the disease as diabetes but there are actually two distinctive types of the disease. Type 1 diabetes is a condition characterized by high blood glucose levels caused by a total lack of insulin. It occurs when the body's immune system attacks the insulin-producing beta cells in the pancreas and destroys them. The pancreas then produces little or no insulin. Type 1 diabetes develops most often in young people but can appear in adults. Type 2 diabetes is the most common form of diabetes. In type 2 diabetes, either the body does not produce enough insulin or the cells ignore the insulin. Insulin is necessary for the body to be able to use sugar. Sugar is the basic fuel for the cells in the body, and insulin takes the sugar from the blood into the cells.

The diagnosis of diabetes often depends on what type the patient is suffering from. In Type 1 diabetes, symptoms are usually sudden and sometimes even life threatening - hyperglycaemia (high blood sugar levels) can lead to comas – and therefore it is mostly diagnosed quite quickly. In Type 2 diabetes, many people have no symptoms at all, while other signs can go unnoticed, being seen as part of 'getting older'. Therefore, by the time symptoms are noticed, the blood glucose level for many people can be very high. Common symptoms include: being more thirsty than usual, passing more urine, feeling lethargic, always feeling hungry, having cuts that heal slowly, itching, skin infections, bad breath, blurred vision, unexplained weight change, mood swings, headaches, feeling dizzy and leg cramps.

At present there is no cure for diabetes, but there is a huge amount of research looking for a cure and to provide superior management techniques and products until a cure is found. Whether it's Type 1 or Type 2 diabetes, the aim of any diabetes treatment is to get your blood glucose levels as close to the non-diabetic range as often as possible. For people with Type 1 diabetes, this will mean insulin injections every day plus leading a healthy lifestyle. For people with Type 2 diabetes, healthy eating and regular physical activity may be all that is required at first: sometimes tablets and/or insulin may be needed later on. Ideally blood glucose levels are kept as close to the non-diabetic range as possible so frequent self-testing is a good idea. This will help prevent the short-term effects of very low or very high blood glucose levels as well as the possible long-term problems. If someone is dependent on insulin, it has to be injected into the body. Insulin cannot

be taken as a pill. The insulin would be broken down during digestion just like the protein in food. Insulin must be injected into the fat under your skin for it to get into your blood.

Diabetes can cause serious complications for patients. When glucose builds up in the blood instead of going into cells, it can cause problems. Short term problems are similar to the symptoms but long term high blood sugar levels can lead to heart attacks, strokes, kidney failure, amputations and blindness. Having your blood pressure and cholesterol outside recommended ranges can also lead to problems like heart attack and stroke and in fact 2 out of 3 people with diabetes eventually die of these complications. Young adults age 18 - 44 who get type 2 diabetes are 14 times more likely to suffer a heart attack, and are up to 30 times more likely to have a stroke than their peers without diabetes. Young women account for almost all the increase in heart attack risk, while young men are twice as likely to suffer a stroke as young women. This means that huge numbers of people are going to get heart disease, heart attacks and strokes years, sometimes even decades, before they should.

#### Questions 1 - 7

Do the following statements reflect the views of the writer in Reading Passage 1? Write:

YES *if the statement agrees with the information*  
 NO *if the statement contradicts the statement*  
 NOT GIVEN *if there is no information on this in the passage*

1. Carbohydrate foods are the body's source of glucose.
2. Diabetics cannot produce insulin.
3. Some patients develop diabetes due to faults in their own immune systems
4. Hyperglycaemia leads to type 1 diabetes being diagnosed quite quickly.
5. Artificial insulin is the most effective treatment for those patients requiring insulin.
6. Frequent check ups at the doctor can drastically reduce the chances of suffering from problems related to diabetes.
7. The majority of diabetics develop heart problems or suffer strokes.

#### Questions 8 - 11

Complete the following statements with the best ending from the box on the next page

8. Bizarre as it may seem, many people with diabetes...
9. Insulin is a hormone that allows glucose to be absorbed by...
10. Non severe type 2 diabetes can be solely treated by...
11. Increases in diabetes related heart problems are mainly seen in...

- |   |
|---|
| <p>A. a healthy lifestyle.<br/>         B. never suffer any ill effects.<br/>         C. women.<br/>         D. people also suffering strokes.<br/>         E. body cells.<br/>         F. the pancreas.<br/>         G. do not realise the fact.<br/>         H. injections.</p> |
|---|

#### Questions 12 - 14

According to the text which of the following are symptoms of diabetes?

Choose THREE letters (A – G) and write them in boxes 12 – 14 on your answer sheet.

- A. hot flushes
- B. muscle pains
- C. nausea
- D. losing consciousness
- E. tiredness
- F. bleeding gums
- G. dilation of the eyes

## READING PASSAGE 2

**Contaminating the Arctic**

Our perception of the Arctic region is that its distance from industrial centers keeps it pristine and clear from the impact of pollution. However, through a process known as transboundary pollution, the Arctic is the recipient of contaminants whose sources are thousands of miles away. Large quantities of pollutants pour into our atmosphere, as well as our lakes, rivers, and oceans on a daily basis. In the last 20 years, scientists have detected an increasing variety of toxic contaminants in the North, including pesticides from agriculture, chemicals and heavy metals from industry, and even radioactive fall-out from Chernobyl. These are substances that have invaded ecosystems virtually worldwide, but they are especially worrisome in the Arctic.

Originally, Arctic contamination was largely blamed on chemical leaks, and these leaks were thought to be “small and localized.” The consensus now is that pollutants from around the world are being carried north by rivers, ocean currents, and atmospheric circulation. Due to extreme conditions in the Arctic, including reduced sunlight, extensive ice cover and cold temperatures, contaminants break down much more slowly than in warmer climates. Contaminants can also become highly concentrated due to their significantly lengthened life span in the Arctic.

Problems of spring run-off into coastal waters during the growth period of marine life are of critical concern. Spring algae blooms easily, absorbing the concentrated contaminants released by spring melting. These algae are in turn eaten by zooplankton and a wide variety of marine life. The accumulation of these contaminants increases with each step of the food chain or web and can potentially affect northerners who eat marine mammals near the top of the food chain. Pollutants respect no borders; transboundary pollution is the movement of contaminants across political borders, whether by air, rivers, or ocean currents. The eight circumpolar nations, led by the Finnish Initiative of 1989, established the Arctic Environmental Protection Strategy (AEPS) in which participants have agreed to develop an Arctic Monitoring and Assessment Program (AMAP). AMAP establishes an international scientific network to monitor the current condition of the Arctic with respect to specific contaminants. This monitoring program is extremely important because it will give a scientific basis for understanding the scope of the problem.

In the 1950's, pilots traveling on weather reconnaissance flights in the Canadian high Arctic reported seeing bands of haze in the springtime in the Arctic region. It was during this time that the term “Arctic haze” was first used, referring to this smog of unknown origin. But it was not until 1972, that Dr. Glenn Shaw of the Geophysical Institute at the University of Alaska first put forth ideas of the nature and long-range origin of Arctic haze. The idea that the source was long range was very difficult for many to support. Each winter, cold, dense air settles over the Arctic. In the darkness, the Arctic seems to become more and more polluted by a buildup of mid-latitude emissions from fossil fuel combustion, smelting and other industrial processes. By late winter, the Arctic is covered by a layer of this haze the size of the continent of Africa. When the spring light arrives in the Arctic, there is a smog-like haze, which makes the region, at times, look like pollution over such cities as Los Angeles. This polluted air is a well-known and well-characterized feature of the late winter Arctic environment. In the North American Arctic, episodes of brown or black snow have been traced to continental storm tracks that deliver gaseous and particulate-associated contaminants from Asian deserts and agricultural areas. It is now known that the contaminants originate largely from Europe and Asia.

Arctic haze has been studied most extensively in Point Barrow, Alaska, across the Canadian Arctic and in Svalbard (Norway). Evidence from ice cores drilled from the ice sheet of Greenland indicates that these haze particles were not always present in the Arctic, but began to appear only in the last century. The Arctic haze particles appear to be similar to smog particles observed in industrial areas farther south, consisting mostly of sulfates mixed with particles of carbon. It is believed the particles are formed when gaseous sulfur dioxide produced by burning sulfur-bearing coal is irradiated by sunlight and oxidized to sulfate, a process catalyzed by trace elements in the air. These sulfate particles or droplets of sulfuric acid quickly capture the carbon particles, which are also floating in the air. Pure sulfate particles or droplets are colourless, so it is believed the darkness of the haze is caused by the mixed-in carbon particles.

The impact of the haze on Arctic ecosystems, as well as the global environment, has not been adequately researched. The pollutants have only been studied in their aerosol form over the Arctic. However, little is known about what eventually happens to them. It is known that they are removed somehow. There is a good degree of likelihood that the contaminants end up in the ocean, likely into the North Atlantic, the Norwegian Sea and possibly the Bering Sea — all three very important fisheries.

Currently, the major issue among researchers is to understand the impact of Arctic haze on global climate change. The contaminants absorb sunlight and, in turn, heat up the atmosphere. The global impact of this is currently unknown but the implications are quite powerful.

#### Questions 15 - 27

Read the passage about alternative farming methods in Oregon again and look at the statements below. Write

TRUE *if the statement is true*  
 FALSE *if the statement is false*  
 NOT GIVEN *if the information is not given in the advertisement*

15. Industry in the Arctic has increased over the last 20 years.
16. Arctic conditions mean that the breakdown of pollutants is much accelerated
17. Pollution absorbed by arctic algae can eventually affect humans.
18. The AEPS has set up scientific stations in the Arctic to monitor pollution.
19. Arctic pollution can sometimes resemble US urban pollution.
20. Evidence that this smog has only occurred in the 20th Century has been found in the ice on the polar ice cap.
21. Research has shown that aerosol arctic pollutants remain the air indefinitely.

#### Questions 22-27 Complete the summary relating to Arctic Haze below.

Choose your answers from the box below the summary and write them in boxes 22 – 27 on your answer sheet. NB There are more words than spaces, so you will not use them all.

Theories (example) that the origins of spring, arctic haze, first seen over the ice cap in the 1950s, came from far away were at first not (22) \_\_\_\_\_. This haze is a smog formed in the dark, arctic winter by pollution delivered to the Arctic by storms (23) \_\_\_\_\_ in Europe and Asia. It is known to be a recent phenomenon as proof from (24) \_\_\_\_\_ shows it only starting to occur in the 20th Century. The smog consists of sulphates and carbon, the latter creating the (25) \_\_\_\_\_ of the haze. Due to lack of research, the final destination of the pollution is unknown but it probably ends up in the (26) \_\_\_\_\_ and therefore into the food chain. Scientists are presently more worried about the (27) \_\_\_\_\_ effect it has on climate change.

burning	terrible	ice cores	valid	certain
originating	sea	destroying	theories	unknown
agriculture	decided	bird life	dissipating	accepted

## READING PASSAGE 3 Questions 28 - 40

**THE STORY OF COFFEE****A**

Coffee was first discovered in Eastern Africa in an area we know today as Ethiopia. A popular legend refers to a goat herder by the name of Kaldi, who observed his goats acting unusually friskily after eating berries from a bush. Curious about this phenomenon, Kaldi tried eating the berries himself. He found that these berries gave him renewed energy.

**B**

The news of this energy laden fruit quickly moved throughout the region. Coffee berries were transported from Ethiopia to the Arabian Peninsula, and were first cultivated in what today is the country of Yemen. Coffee remained a secret in Arabia before spreading to Turkey and then to the European continent by means of Venetian trade merchants.

**C**

Coffee was first eaten as a food though later people in Arabia would make a drink out of boiling the beans for its narcotic effects and medicinal value. Coffee for a time was known as Arabian wine to Muslims who were banned from alcohol by Islam. It was not until after coffee had been eaten as a food product, a wine and a medicine that it was discovered, probably by complete accident in Turkey, that by roasting the beans a delicious drink could be made. The roasted beans were first crushed, and then boiled in water, creating a crude version of the beverage we enjoy today. The first coffee houses were opened in Europe in the 17th Century and in 1675, the Viennese established the habit of refining the brew by filtering out the grounds, sweetening it, and adding a dash of milk.

**D**

If you were to explore the planet for coffee, you would find about 60 species of coffee plants growing wild in Africa, Malaysia, and other regions. But only about ten of them are actually cultivated. Of these ten, two species are responsible for almost all the coffee produced in the world: *Coffea Arabica* and *Coffea Canephora* (usually known as Robusta). Because of ecological differences existing among the various coffee producing countries, both types have undergone many mutations and now exist in many sub species.

**E**

Although wild plants can reach 10 - 12 metres in height, the plantation one reaches a height of around four metres. This makes the harvest and flowering easier, and cultivation more economical. The flowers are white and sweet-scented like the Spanish jasmine. Flowers give way to a red, darkish berry. At first sight, the fruit is like a big cherry both in size and in colour. The berry is coated with a thin, red film (epicarp) containing a white, sugary mucilaginous flesh (mesocarp). Inside the pulp there are the seeds in the form of two beans coupled at their flat surface. Beans are in turn coated with a kind of resistant, golden yellow parchment, (called endocarp). When peeled, the real bean appears with another very thin silvery film. The bean is bluish green verging on bronze, and is at the most 11 millimetres long and 8 millimetres wide.

**F**

Coffee plants need special conditions to give a satisfactory crop. The climate needs to be hot-wet or hot temperate, between the Tropic of Cancer and the Tropic of Capricorn, with frequent rains and temperatures varying from 15 to 25 Degrees C. The soil should be deep, hard, permeable, well irrigated, with well-drained subsoil. The best lands are the hilly ones or from just-tilled woods. The perfect altitude is between 600 and 1200 metres, though some varieties thrive at 2000-2200 metres. Cultivation aimed at protecting the plants at every stage of growth is needed. Sowing should be in sheltered nurseries from which, after about six months, the seedlings should be moved to plantations in the rainy season where they are usually alternated with other plants to shield them from wind and excessive sunlight. Only when the plant is five years old can it be counted upon to give a regular yield. This is between 400 grams and two kilos of arabica beans for each plant, and 600 grams and two kilos for robusta beans.



**G**

Harvesting time depends on the geographic situation and it can vary greatly therefore according to the various producing countries. First the ripe beans are picked from the branches. Pickers can selectively pick approximately 250 to 300 pounds of coffee cherry a day. At the end of the day, the pickers bring their heavy burlap bags to pulping mills where the cherry coffee can be pulped (or wet milled). The pulped beans then rest, covered in pure rainwater to ferment overnight. The next day the wet beans are hand-distributed upon the drying floor to be sun dried. This drying process takes from one to two weeks depending on the amount of sunny days available. To make sure they dry evenly, the beans need to be raked many times during this drying time. Two weeks later the sun dried beans, now called parchment, are scooped up, bagged and taken to be milled. Huge milling machines then remove the parchment and silver skin, which renders a green bean suitable for roasting. The green beans are roasted according to the customers' specifications and, after cooling, the beans are then packaged and mailed to customers.

**Questions 28 - 33**

The reading passage on *The Story of Coffee* has 7 paragraphs A – G. From the list of headings below choose the most suitable headings for paragraphs B-G.

Write the appropriate number (i – xi) in boxes 28 – 33 on your answer sheet.

NB There are more headings than paragraphs, so you will not use them all.

<i>Example</i>	<i>Answer</i>
Paragraph A	iv
28. Paragraph B	
29. Paragraph C	
30. Paragraph D	
31. Paragraph E	
32. Paragraph F	
33. Paragraph G	

i	Growing Coffee
ii	Problems with Manufacture
iii	Processing the Bean
iv	First Contact
v	Arabian Coffee
vi	Coffee Varieties
vii	Modern Coffee
viii	The Spread of Coffee
ix	Consuming Coffee
x	Climates for Coffee
xi	The Coffee Plant

**Questions 34 - 36**

Complete the labels on the diagram of a coffee bean below. Choose your answers from the text and write them in boxes 34 - 36 on your answer sheet.

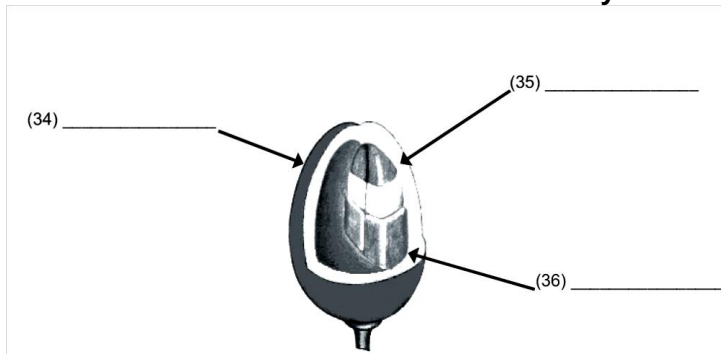

**Questions 37 – 40**

Using the information in the passage, complete the flow chart below.

Write your answers in boxes 37 – 40 on your answer sheet.

Use NO MORE THAN THREE WORDS from the passage for each answer.

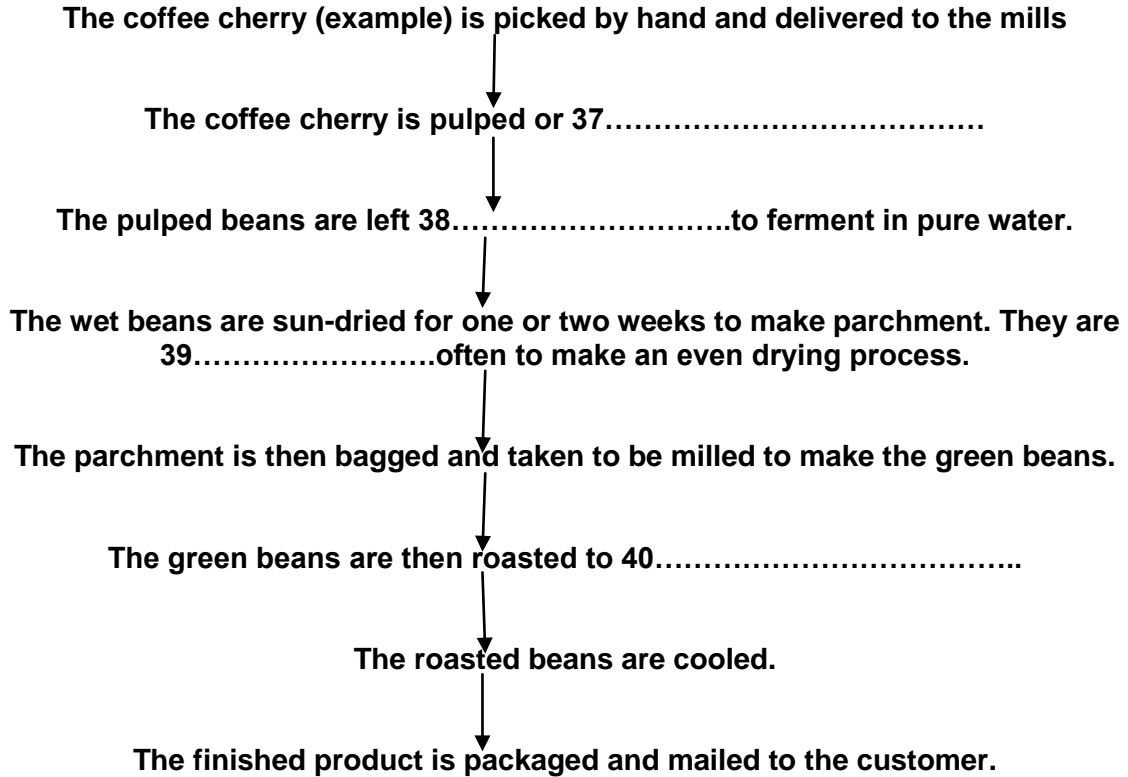
**The Coffee Production Process**

Help Now Academic Reading TEST 3  
READING PASSAGE 1 Questions 1 - 14

### Cleaning up The Thames

The River Thames, which was biologically “dead” as recently as the 1960s, is now the cleanest metropolitan river in the world, according to the Thames Water Company. The company says that thanks to major investment in better sewage treatment in London and the Thames Valley, the river that flows through the United Kingdom capital and the Thames Estuary into the North Sea is cleaner now than it has been for 130 years. The Fisheries Department, who are responsible for monitoring fish levels in the River Thames, has reported that the river has again become the home to 115 species of fish including sea bass, flounder, salmon, smelt, and shad. Recently, a porpoise was spotted cavorting in the river near central London.

But things were not always so rosy. In the 1950s, sewer outflows and industrial effluent had killed the river. It was starved of oxygen and could no longer support aquatic life. Until the early 1970s, if you fell into the Thames you would have had to be rushed to hospital to get your stomach pumped. A clean-up operation began in the 1960s. Several Parliamentary Committees and Royal Commissions were set up, and, over time, legislation has been introduced that put the onus on polluters - effluent-producing premises and businesses - to dispose of waste responsibly. In 1964 the Greater London Council (GLC) began work on greatly enlarged sewage works, which were completed in 1974.

The Thames clean up is not over though. It is still going on, and it involves many disparate arms of government and a wide range of non-government stakeholder groups, all representing a necessary aspect of the task. In London’s case, the urban and non-urban London boroughs that flank the river’s course each has its own reasons for keeping “their” river nice. And if their own reasons do not hold out a sufficiently attractive carrot, the government also wields a compelling stick. The 2000 Local Government Act requires each local borough to “prepare a community strategy for promoting or improving the economic, social and environmental well-being of their area.” And if your area includes a stretch of river, that means a sustainable river development strategy.

Further legislation aimed at improving and sustaining the river’s viability has been proposed. There is now legislation that protects the River Thames, either specifically or as part of a general environmental clause, in the Local Government Act, the London Acts, and the law that created the post of the mayor of London. And these are only the tip of an iceberg that includes industrial, public health and environmental protection regulations. The result is a wide range of bodies officially charged, in one way or another, with maintaining the Thames as a public amenity. For example, Transport for London - the agency responsible for transport in the capital - plays a role in regulating river use and river users. They now are responsible for controlling the effluents and rubbish coming from craft using the Thames. This is done by officers on official vessels regularly inspecting craft and doing spot checks. Another example is how Thames Water (TW) has now been charged to reduce the amount of litter that finds its way into the tidal river and its tributaries. TW’s environment and quality manager, Dr. Peter Spillett, said: “This project will build on our investment which has dramatically improved the water quality of the river. London should not be spoiled by litter which belongs in the bin not the river.” Thousands of tons of rubbish end up in the river each year, from badly stored



**READING PASSAGE 2**                      **Questions 15 - 27**

If it weren't for nicotine, people wouldn't smoke tobacco. Why? Because of the more than 4000 chemicals in tobacco smoke, nicotine is the primary one that acts on the brain, altering people's moods, appetites and alertness in ways they find pleasant and beneficial.

Unfortunately, as it is widely known, nicotine has a dark side: it is highly addictive. Once smokers become hooked on it, they must get their fix of it regularly, sometimes several dozen times a day. Cigarette smoke contains 43 known carcinogens, which means that long-term smoking can amount to a death sentence. In the US alone, 420,000 Americans die every year from tobacco-related illnesses.

Breaking nicotine addiction is not easy. Each year, nearly 35 million people make a concerted effort to quit smoking. Sadly, less than 7 percent succeed in abstaining for more than a year; most start smoking again within days. So what is nicotine and how does it insinuate itself into the smoker's brain and very being?

The nicotine found in tobacco is a potent drug and smokers, and even some scientists, say it offers certain benefits. One is enhance performance. One study found that non-smokers given doses of nicotine typed about 5 percent faster than they did without it. To greater or lesser degrees, users also say nicotine helps them to maintain concentration, reduce anxiety, relieve pain, and even dampen their appetites (thus helping in weight control). Unfortunately, nicotine can also produce deleterious effects beyond addiction. At high doses, as are achieved from tobacco products, it can cause high blood pressure, distress in the respiratory and gastrointestinal systems and an increase in susceptibility to seizures and hypothermia.

First isolated as a compound in 1828, in its pure form nicotine is a clear liquid that turns brown when burned and smells like tobacco when exposed to air. It is found in several species of plants, including tobacco and, perhaps surprisingly, in tomatoes, potatoes, and eggplant (though in extremely low quantities that are pharmacologically insignificant for humans).

As simple as it looks, the cigarette is highly engineered nicotine delivery device. For instance, when tobacco researchers found that much of the nicotine in a cigarette wasn't released when burned but rather remained chemically bound within the tobacco leaf, they began adding substances such as ammonia to cigarette tobacco to release more nicotine. Ammonia helps keep nicotine in its basic form, which is more readily vaporised by the intense heat of the burning cigarette than the acidic form. Most cigarettes for sale in the US today contain 10 milligrams or more of nicotine. By inhaling smoke from a lighted cigarette, the average smoker takes 1 or 2 milligrams of vaporised nicotine per cigarette. Today we know that only a miniscule amount of nicotine is needed to fuel addiction. Research shows that manufacturers would have to cut nicotine levels in a typical cigarette by 95% to forestall its power to addict. When a smoker puffs on a lighted cigarette, smoke, including vaporised nicotine, is drawn into the mouth. The skin and lining of the mouth immediately absorb some nicotine, but the remainder flows straight down into the lungs, where it easily diffuses into the blood vessels lining the lung walls. The blood vessels carry the nicotine to the heart, which then pumps it directly to the brain. While most of the effects a smoker seeks occur in the brain, the heart takes a hit as well. Studies have shown that a smoker's first cigarette of the day can increase his or her heart rate by 10 to 20 beats a minute. Scientists have found that a smoked substance reaches the brain more quickly than one swallowed, snorted (such as cocaine powder) or even injected. Indeed, a nicotine molecule inhaled in smoke will reach the brain within 10 seconds. The nicotine travels through blood vessels, which branch out into capillaries within the brain. Capillaries normally carry nutrients but they readily accommodate nicotine molecules as well. Once inside the brain, nicotine, like most addictive drugs, triggers the release of chemicals associated with euphoria and pleasure.

Just as it moves rapidly from the lungs into the bloodstream, nicotine also easily diffuses through capillary walls. It then migrates to the spaces surrounding neurones – ganglion cells that transmit nerve impulses throughout the nervous system. These impulses are the basis for our thoughts, feelings, and moods. To transmit nerve impulses to its neighbour, a neurone releases chemical messengers known as neurotransmitters. Like nicotine molecules, the neurotransmitters drift into the so-called synaptic space between neurones, ready to latch onto the receiving neurone and thus deliver a chemical “message” that triggers an electrical impulse.

The neurotransmitters bind onto receptors on the surface of the recipient neurone. This opens channels in the cell surface through which enter ions, or charged atoms, of sodium. This generates a current across the membrane of the receiving cell, which completes delivery of the “message”. An accomplished mimic, nicotine competes with the neurotransmitters to bind to the receptors. It wins and, like the vanquished chemical, opens ion channels that let sodium ions into the cell. But there’s a lot more nicotine around than the original transmitter, so a much larger current spreads across the membrane. This bigger current causes increased electrical impulses to travel along certain neurones. With repeated smoking, the neurones adapt to this increased electrical activity, and the smoker becomes dependent on the nicotine.

#### Questions 15 - 21

Do the following statements agree with the views of the writer of Reading Passage 2?

- YES *if the statement agrees with the writer*  
 NO *if the statement doesn't agree with the writer*  
 NOT GIVEN *if it is impossible to say what the writer thinks about this*

15. Although nicotine is probably the well-known chemical in cigarettes, it is not necessarily the one that changes the psyche of the smoker when cigarettes are smoked.
16. In spite of the difficulties, according to the text more than thirty-five million people a year give up smoking.
17. It has been shown that nicotine in cigarettes can improve people’s abilities to perform some actions more quickly.
18. Added ammonia in cigarettes allows smokers to inhale more nicotine.
19. Snorted substances reach the brain faster than injected substances.
20. Nicotine dilates the blood vessels that carry it around the body.
21. Nicotine molecules allow greater electrical charges to pass between neurones.

#### Questions 22 - 26

Using NO MORE THAN THREE WORDS OR A NUMBER from Reading Passage 2, answer the following questions.

- 22 What is the natural colour of nicotine?
- 23 By how much would cigarette companies have to cut the nicotine content in cigarettes to prevent them from being addictive?
- 24 Name ONE of 2 things that first take nicotine into a smoker’s body?
- 25 According to the passage, by how many beats a minute can a cigarette raise a smoker’s heart rate?
- 26 What type of cell in the human body encloses neurones?

#### Questions 27

From the list below choose the most suitable title for Reading Passage 2.

- A How to Quit Smoking
- B The Dangers of Smoking
- C Cell Biology
- D Why Smoking is Addictive
- E Nicotine is a Poison

**READING PASSAGE 3** Questions 28 - 40**Questions 28 - 32**

The reading passage on *Deer Farming In Australia* has 5 paragraphs (A – E). From the list of headings below choose the most suitable headings for paragraphs A – E. NB There are more headings than paragraphs, so you will not use them all.

- 28 Paragraph A  
29 Paragraph B  
30 Paragraph C  
31 Paragraph D  
32 Paragraph E

i	Industry Structures
ii	Disease Affects Production
iii	Trends in Production
iv	Government Assistance
v	How Deer Came to Australia
vi	Research and Development
vii	Asian Competition
viii	Industry Development

## Deer Farming In Australia

### Paragraph A

Deer are not indigenous to Australia. They were introduced into the country during the nineteenth century under the acclimatization programs governing the introduction of exotic species of animals and birds into Australia. Six species of deer were released at various locations. The animals dispersed and established wild populations at various locations across Australia, mostly depending upon their points of release into the wild. These animals formed the basis for the deer industry in Australia today.

Commercial deer farming in Australia commenced in Victoria in 1971 with the authorized capture of rusa deer from the Royal National Park, NSW. Until 1985, only four species of deer, two from temperate climates (red, fallow) and two tropical species (rusa, chital) were confined for commercial farming. Late in 1985, pressure from industry to increase herd numbers saw the development of import protocols. This resulted in the introduction of large numbers of red deer hybrids from New Zealand and North American elk directly from Canada. The national farmed deer herd is now distributed throughout all states although most are in New South Wales and Victoria.

### Paragraph B

The number of animals processed annually has continued to increase, despite the downward trend in venison prices since 1997. Of concern is the apparent increase in the number of female animals processed and the number of whole herds committed for processing. With more than 40,000 animals processed in 1998/99 and 60,000 in 1999/2000, there is justified concern that future years may see a dramatic drop in production. At least 85% of all venison produced in Australia is exported, principally to Europe. At least 90% of all velvet antler produced is exported in an unprocessed state to Asia.

Schemes to promote Australian deer products continue to have a positive effect on sales that in turn have a positive effect on prices paid to growers. The industry appears to be showing limited signs that it is emerging from a state of depression caused by both internal and external factors that include: (i) the Asian currency downturn; (ii) the industry's lack of competitive advantage in influential markets (particularly in respect to New Zealand competition), and; (iii) within industry processing and marketing competition for limited product volumes of venison.

### Paragraph C

From the formation of the Australian Deer Breeders Federation in 1979, the industry representative body has evolved through the Deer Farmers Federation of Australia to the Deer Industry Association of Australia Ltd (DIAA), which was registered in 1995. The industry has established two product development and marketing companies, the Australian Deer Horn and Co-Products Pty Ltd (ADH) and the Deer Industry Projects and Development Pty Ltd, which trades as the Deer Industry Company (DIC). ADH collects and markets Australian deer horn and co-products on behalf of Australian deer farmers. It promotes the harvest of

velvet antler according to the strict quality assurance program promoted by the industry. The company also plans and co-ordinates regular velvet accreditation courses for Australian deer farmers.

**Paragraph D**

Estimates suggest that until the early 1990s the rate of the annual increase in the number of farmed deer was up to 25%, but after 1993 this rate of increase fell to probably less than 10%. The main reasons for the decline in the deer herd growth rate at such a critical time for the market were: (i) severe drought conditions up to 1998 affecting eastern Australia during 1993-96 and (ii) the consequent slaughter of large numbers of breeding females, at very low prices. These factors combined to decrease confidence within the industry. Lack of confidence saw a drop in new investment within the industry and a lack of willingness of established farmers to expand their herds. With the development of strong overseas markets for venison and velvet and the prospect of better seasons ahead in 1996, the trends described were seen to have been significantly reversed. However, the relatively small size of the Australian herd was seen to impose undesirable restraints on the rate at which herd numbers could be expanded to meet the demands for products.

Supply difficulties were exacerbated when the supply of products, particularly venison, was maintained by the slaughter of young breeding females. The net result was depletion of the industry's female breeding herds.

**Paragraph E**

Industry programs are funded by statutory levies on sales of animals for venison, velvet antler sales and the sale of live animals into export markets. The industry has a 1996 - 2000 five year plan including animal nutrition, pasture quality, carcass quality, antler harvesting, promotional material and technical bulletins. All projects have generated a significant volume of information, which compliments similar work undertaken in New Zealand and other deer farming countries.

Major projects funded by levy funds include the Venison Market Project from 1992 to 1996. This initiative resulted in a dramatic increase in international demand for Australian venison and an increase in the domestic consumption of venison. In an effort to maintain existing venison markets in the short term and to increase them in the long term, in 1997 the industry's top priority became the increase in size and production capacity of the national herd.

**Questions 33 - 37**

Read the passage about *Deer Farming in Australia* again and look at the statements below.

TRUE *if the statement is true*

FALSE *if the statement is false*

NOT GIVEN *if the information is not given in Reading Passage 3*

33. Until 1985 only 2 species of the originally released Australian deer were not used for farming.
34. Since 1985 many imported deer have been interbred with the established herds.
35. The drop in deer numbers since 1997 led to an increase in the price of venison.
36. Only a small amount of Australian venison production is consumed domestically.
37. Current economic conditions in Asian countries have had positive effect on the Australian deer industry.

**Questions 38 - 40**

Complete each of the following statements (Questions 38 - 40) with words taken from Reading Passage 3. Write NO MORE THAN THREE WORDS for each answer.

38 A stringent \_\_\_\_\_ allows the Australian deer industry to maintain their excellence of product.

39 Herd stock expansion was made difficult by the killing of \_\_\_\_\_ to continue product supply.

40 Foreign and home markets for Australian venison increased due to the



**Help Now Academic Reading TEST 4****READING PASSAGE 1****Questions 1 – 14****Questions 1 - 6**

Reading Passage 1 has 7 paragraphs (A – G). From the list of headings below choose the most suitable headings for paragraphs B – G. NB There are more headings than paragraphs, so you will not use them all.

Example

Paragraph A

1. Paragraph B
2. Paragraph C
3. Paragraph D
4. Paragraph E
5. Paragraph F
6. Paragraph G

Answer

iv

List of headings

- i. Factory Closures
- ii. The Human Cost
- iii. The Tragedy of State Mismanagement
- iv. A Warning to the World
- v. European Techniques
- vi. Destructive Trawling Technology
- vii. Lessons to be Learned
- viii. The Demise of the Northern Cod
- ix. Canadian Fishing Limits
- x. The Breaking of Agreements
- xi. Foreign Over-fishing

## **COD IN TROUBLE**

**A**

In 1992, the devastating collapse of the cod stocks off the East coast of Newfoundland forced the Canadian government to take drastic measures and close the fishery. Over 40,000 people lost their jobs, communities are still struggling to recover and the marine ecosystem is still in a state of collapse. The disintegration of this vital fishery sounded a warning bell to governments around the world who were shocked that a relatively sophisticated, scientifically based fisheries management program, not unlike their own, could have gone so wrong. The Canadian government ignored warnings that their fleets were employing destructive fishing practices and refused to significantly reduce quotas citing the loss of jobs as too great a concern.

**B**

In the 1950s Canadian and US east coast waters provided an annual 100,000 tons in cod catches rising to 800,000 by 1970. This over fishing led to a catch of only 300,000 tons by 1975. Canada and the US reacted by passing legislation to extend their national jurisdictions over marine living resources out to 200 nautical miles and catches naturally declined to 139,000 tons in 1980. However the Canadian fishing industry took over and restarted the over fishing and catches rose again until, from 1985, it was the Canadians who were landing more than 250,000 tons of northern cod annually. This exploitation ravaged the stocks and by 1990 the catch was so low (29,000 tons) that in 1992 (121/2000 tons) Canada had to ban all fishing in east coast waters. In a fishery that had for over a century yielded a quarter-million ton catches, there remained a biomass of less than 1700 tons and the fisheries department also predicted that, even with an immediate recovery, stocks need at least 15 years before they would be healthy enough to withstand previous levels of fishing.

**C**

The devastating fishing came from massive investment poured into constructing huge “dragners”. Dragners haul enormous nets held open by a combination of huge steel plates and heavy chains and rollers that plough the ocean bottom. They drag up anything in the way, inflicting immense damage, destroying critical habitat and contributing to the destabilization of the northern cod ecosystem. The dragners targeted huge aggregations of cod while they were spawning, a time when the fish population is highly vulnerable to capture. Excessive trawling on spawning stocks became highly disruptive to the spawning

process and ecosystem. In addition, the trawling activity resulted in a physical dispersion of eggs leading to a higher fertilization failure. Physical and chemical damage to larvae caused by the trawling action also reduced their chances of survival. These draggers are now banned forever from Canadian waters.

**D**

Canadian media often cite excessive fishing by overseas fleets, primarily driven by the capitalist ethic, as the primary cause of the fishing out of the north Atlantic cod stocks. Many nations took fish off the coast of Newfoundland and all used deep-sea trawlers, and many often blatantly exceeded established catch quotas and treaty agreements. There can be little doubt that non North American fishing was a contributing factor in the cod stock collapse, and that the capitalist dynamics that were at work in Canada were all too similar for the foreign vessels and companies. But all of the blame cannot be put there, no matter how easy it is to do, as it does not account for the management of the resources.

**E**

Who was to blame? As the exploitation of the Newfoundland fishery was so predominantly guided by the government, we can argue that a fishery is not a private area, as the fisher lacks management rights normally associated with property and common property. The state had appropriated the property, and made all of the management decisions. Fishermen get told who can fish, what they can fish, and essentially, what to do with the fish once it is caught. In this regard then, when a resource such as the Newfoundland fishery collapses, it is more a tragedy of government negligence than a tragedy of the general public.

**F**

Following the '92 ban on northern cod fishing and most other species, an estimated 30 thousand people that had already lost their jobs after the 1992 Northern Cod moratorium took effect, were joined by an additional 12,000 fishermen and plant workers. With more than forty thousand people out of jobs, Newfoundland became an economic disaster area, as processing plants shut down, and vessels from the smallest dory to the monster draggers were made idle or sold overseas at bargain prices. Several hundred Newfoundland communities were devastated.

**G**

Europeans need only look across the North Atlantic to see what could be in store for their cod fishery. In Canada they were too busy with making plans, setting expansive goals, and then allocating fish, and lots of it, instead of making sound business plans to match fishing with the limited availability of the resource. Cod populations in European waters are now so depleted that scientists have recently warned that "all fisheries in this area that target cod should be closed." The Canadian calamity demonstrates that we now have the technological capability to find and annihilate every commercial fish stock, in any ocean and do irreparable damage to entire ecosystems in the process. In Canada's case, a two billion dollar recovery bill may only be a part of the total long-term costs. The costs to individuals and desperate communities now deprived of meaningful and sustainable employment is staggering.

### **Questions 7 - 10**

Choose the appropriate letters A – D and write them in boxes 7 – 10 on your answer sheet.

7. The Canadian government didn't want to reduce cod catches pre 1992 because they were worried about...
  - A. possible rising unemployment
  - B. the ecological effects
  - C. the marine ecosystem
  - D. drastic measures

8. Which graph most accurately describes Canadian cod catches from 1950 to 1992?

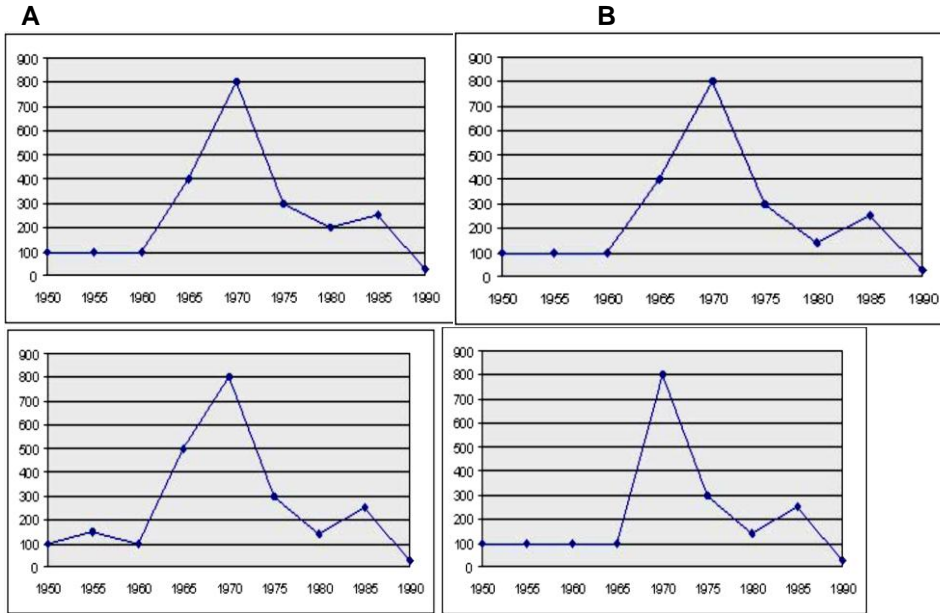

9. According to Reading Passage 1, which of the following is now true about the Newfoundland fisheries?

- A. Catches of 1700 tons a year only are permitted.
  - B. Normal fishing could start again in 2007.
  - C. No cod fishing is allowed but some other species can be caught.
  - D. Fishing with dragnets will be allowed again in 2007.
10. Who does the writer blame for the collapse of the Newfoundland cod fishery?
- A. The Canadian fishing industry.
  - B. The foreign fishing industry.
  - C. The Canadian government.
  - D. The US fishing industry.

**Questions 11 - 14**

Do the following statements agree with the views of the writer of the reading passage on Cod in Trouble?

- YES if the statement agrees with the writer
- NO if the statement doesn't agree with the writer
- NOT GIVEN if it is impossible to say what the writer thinks about this

- 11. Disruption of cod breeding was a major factor in the Newfoundland cod disaster.
- 12. Foreign trawlers frequently broke the catch allowances.
- 13. There was often conflict between the foreign fishermen and the Canadian authorities.
- 14. Europe does not face the seriousness of the Canadian disaster.

**READING PASSAGE 2**

**The Rise of Antibiotic-Resistant Infections**

A  
When penicillin became widely available during the Second World War, it was a medical miracle, rapidly vanquishing the biggest wartime killer - infected wounds. Discovered initially by a French medical student, Ernest Duchesne, in 1896, and then rediscovered by Scottish

physician Alexander Fleming in 1928, *Penicillium* crippled many types of disease-causing bacteria. But just four years after drug companies began mass-producing penicillin in 1943, microbes began appearing that could resist it.

**B**

“There was complacency in the 1980s. The perception was that we had licked the bacterial infection problem. Drug companies weren’t working on new agents. They were concentrating on other areas, such as viral infections,” says Michael Blum, M.D., medical officer in the Food and Drug Administration’s division of anti-infective drug products. “In the meantime, resistance increased to a number of commonly used antibiotics, possibly related to overuse. In the 1990s, we’ve come to a point for certain infections that we don’t have agents available.”

**C**

The increased prevalence of antibiotic resistance is an outcome of evolution. Any population of organisms, bacteria included, naturally includes variants with unusual traits - in this case, the ability to withstand an antibiotic’s attack on a microbe. When a person takes an antibiotic, the drug kills the defenceless bacteria, leaving behind - or “selecting,” in biological terms - those that can resist it. These renegade bacteria then multiply, increasing their numbers a million fold in a day, becoming the predominant microorganism. “Whenever antibiotics are used, there is selective pressure for resistance to occur. More and more organisms develop resistance to more and more drugs,” says Joe Cranston, Ph.D., director of the department of drug policy and standards at the American Medical Association in Chicago.

**D**

Disease-causing microbes thwart antibiotics by interfering with their mechanism of action. For example, penicillin kills bacteria by attaching to their cell walls, then destroying a key part of the wall. The wall falls apart, and the bacterium dies. Resistant microbes, however, either alter their cell walls so penicillin can’t bind or produce enzymes that dismantle the antibiotic.

Antibiotic resistance results from gene action. Bacteria acquire genes conferring resistance in different ways. Bacterial DNA may mutate spontaneously. Drug-resistant tuberculosis arises this way. Another way is called transformation where one bacterium may take up DNA from another bacterium. Most frightening, however, is resistance acquired from a small circle of DNA called a plasmid, which can flit from one type of bacterium to another. A single plasmid can provide a slew of different resistances.

**E**

Many of us have come to take antibiotics for granted. A child develops a sore throat or an ear infection, and soon a bottle of pink medicine makes everything better. Linda McCaig, a scientist at the CDC, comments that “many consumers have an expectation that when they’re ill, antibiotics are the answer. Most of the time the illness is viral, and antibiotics are not the answer. This large burden of antibiotics is certainly selecting resistant bacteria.” McCaig and Peter Killeen, a fellow scientist at the CDC, tracked antibiotic use in treating common illnesses. The report cites nearly 6 million antibiotic prescriptions for sinusitis alone in 1985, and nearly 13 million in 1992. Ironically, advances in modern medicine have made more people predisposed to infection. McCaig notes that “there are a number of immune compromised patients who wouldn’t have survived in earlier times. Radical procedures produce patients who are in difficult shape in the hospital, and there is routine use of antibiotics to prevent infection in these patients.”

**F**

There are measures we can take to slow the inevitable resistance. Barbara Murray, M.D., of the University of Texas Medical School at Houston writes that “simple improvements in public health measures can go a long way towards preventing infection”. Such approaches include more frequent hand washing by health-care workers, quick identification and isolation of patients with drug-resistant infections, and improving sewage systems and water purity.

Drug manufacturers are also once again becoming interested in developing new antibiotics. The FDA is doing all it can to speed development and availability of new antibiotic drugs. “We can’t identify new agents - that’s the job of the pharmaceutical industry. But once they have identified a promising new drug, what we can do is to meet with the company very early and help design the development plan and clinical trials,” says Blum. In addition, drugs in development can be used for patients with multi-drug-resistant infections on an emergency compassionate use basis for people with AIDS or cancer, for example.” Blum adds. Appropriate prescribing is important. This means that physicians use a narrow spectrum antibiotics - those that target only a few bacterial types - whenever possible, so that resistances can be restricted. “There has been a shift to using costlier, broader spectrum agents. This prescribing trend heightens the resistance problem because more diverse bacteria are being exposed to antibiotics,” writes Killeen. So, while awaiting the next wonder drug, we must appreciate, and use correctly, the ones that we already have. Another problem with antibiotic use is that patients often stop taking the drug too soon, because symptoms improve. However, this merely encourages resistant microbes to proliferate. The infection returns a few weeks later, and this time a different drug must be used to treat it. The conclusion: resistance can be slowed if patients take medications correctly.

### Questions 15 - 21

Match the views (15 – 21) with the people listed below.

15. Antibiotics are sometimes used to only prevent infections.
16. Choosing the correct antibiotic for particular infections is important.
17. Today there are some bacterial infections for which we have no effective antibiotic.
18. Untested drugs can be used on terminal patients as a last resort.
19. Resistance develops every time an antibiotic is used.
20. Merely washing hands can have a positive effect.
21. Antibiotics are often impotently used against viruses.

PK Peter Killeen  
 JC Joe Cranston  
 LM Linda McCaig  
 MB Michael Blum  
 BM Barbara Murray

### Questions 22 - 27

Reading Passage 2 has 6 paragraphs (A - F). Which paragraphs concentrate on the following information? Write the appropriate letters (A - F) in boxes 22 - 27 on your answer sheet.

22. How antibiotic resistance happens.
23. The survival of the fittest bacteria.
24. Factors to consider in solving the antibiotic-resistant bacteria problem.
25. The impact of the discovery of the first antibiotic.
26. The misuse and overuse of antibiotics.
27. The cessation of research into combating bacterial infections.

### READING PASSAGE 3

## Hydroelectric Power

Hydroelectric power is America’s leading renewable energy resource. Of all the renewable power sources, it’s the most reliable, efficient, and economical. Water is needed to run a hydroelectric generating unit. It’s held in a reservoir or lake behind a dam, and the force of the water being released from the reservoir through the dam spins the blades of a turbine. The turbine is connected to the generator that produces electricity. After passing through the turbine, the water re-enters the river on the downstream side of the dam.

Hydroelectric plants convert the kinetic energy within falling water into electricity. The energy in moving water is produced in the sun, and consequently is continually being renewed. The energy in sunlight evaporates water from the seas and deposits it on land as rain. Land elevation differences result in rainfall runoff, and permit some of the original solar energy to be harnessed as hydroelectric power. Hydroelectric power is at present the earth's chief renewable electricity source, generating 6% of global energy and about 15% of worldwide electricity. Hydroelectric power in Canada is plentiful and provides 60% of their electrical requirements. Usually regarded as an inexpensive and clean source of electricity, most big hydroelectric projects being planned today are facing a great deal of hostility from environmental groups and local people.

The earliest recorded use of water power was a clock, constructed around 250 BC. Since then, people have used falling water to supply power for grain and saw mills, as well as a host of other uses. The earliest use of flowing water to generate electricity was a waterwheel on the Fox River in Wisconsin in 1882.

The first hydroelectric power plants were much more dependable and efficient than the plants of the day that were fired by fossil fuels. This led to a rise in number of small to medium sized hydroelectric generating plants located wherever there was an adequate supply of falling water and a need for electricity. As demand for electricity soared in the middle years of the 20th century, and the effectiveness of coal and oil power plants improved, small hydro plants became less popular. The majority of new hydroelectric developments were focused on giant mega-projects.

Hydroelectric plants harness energy by passing flowing water through a turbine. The water turbine rotation is delivered to a generator, which generates electricity. The quantity of electricity that can be produced at a hydroelectric plant relies upon two variables. These variables are (1) the vertical distance that the water falls, called the "head", and (2) the flow rate, calculated as volume over time. The amount of electricity that is produced is thus proportional to the head product and the flow rate.

So, hydroelectric power stations can normally be separated into two kinds. The most widespread are "high head" plants and usually employ a dam to stock up water at an increased height. They also store water at times of rain and discharge it during dry times. This results in reliable and consistent electricity generation, capable of meeting demand since flow can be rapidly altered. At times of excess electrical system capacity, usually available at night, these plants can also pump water from one reservoir to another at a greater height. When there is peak electrical demand, the higher reservoir releases water through the turbines to the lower reservoir.

"Low head" hydroelectric plants usually exploit heads of just a few meters or less. These types of power station use a weir or low dam to channel water, or no dam at all and merely use the river flow. Unfortunately their electricity production capacity fluctuates with seasonal water flow in a river.

Until only recently people believed almost universally that hydroelectric power was an environmentally safe and clean means of generating electricity. Hydroelectric stations do not release any of the usual atmospheric pollutants emitted by power plants fuelled by fossil fuels so they do not add to global warming or acid rain. Nevertheless, recent studies of the larger reservoirs formed behind dams have implied that decomposing, flooded vegetation could give off greenhouse gases equal to those from other electricity sources.

The clearest result of hydroelectric dams is the flooding of huge areas of land. The reservoirs built can be exceptionally big and they have often flooded the lands of indigenous peoples

and destroyed their way of life. Numerous rare ecosystems are also endangered by hydroelectric power plant development.

Damming rivers may also change the quantity and quality of water in the rivers below the dams, as well as stopping fish migrating upstream to spawn. In addition, silt, usually taken downstream to the lower parts of a river, is caught by a dam and so the river downstream loses the silt that should fertilize the river's flood plains during high water periods.

Theoretical global hydroelectric power is approximately four times larger than the amount that has been taken advantage of today. Most of the residual hydro potential left in the world can be found in African and Asian developing countries. Exploiting this resource would involve an investment of billions of dollars, since hydroelectric plants normally have very high building costs. Low head hydro capacity facilities on small scales will probably increase in the future as low head turbine research, and the standardization of turbine production, reduce the costs of low head hydro-electric power production. New systems of control and improvements in turbines could lead in the future to more electricity created from present facilities. In addition, in the 1950's and 60's when oil and coal prices were very low, lots of smaller hydroelectric plants were closed down. Future increases in the prices of fuel could lead to these places being renovated.

#### Questions 28 - 32

Read the passage about Hydroelectric Power again and look at the statements below.

Write:

- TRUE                      if the statement is true  
 FALSE                     if the statement is false  
 NOT GIVEN              if the information is not given in the passage

28. Canada uses the most hydroelectric power in the world today.
29. An early use of hydroelectric power was in the timber industry.
30. The first hydroelectric power stations were more effective than those using competing energy sources.
31. People have been drowned by the flooding of their traditional territory when reservoirs are created.
32. Nowadays, agriculture below hydroelectric dams is not affected by the change in water flow.

#### Questions 33 - 36

Complete each of the following statements (Questions 33 - 36) with words taken from Reading Passage 3. Write NO MORE THAN THREE WORDS for each answer.

33. The origin of hydroelectric power is the \_\_\_\_\_ produced when water obeys the laws of gravity.
34. How far water drops to the turbines in a power station is known as \_\_\_\_\_.
35. A drawback to low head hydroelectric power stations is that they depend on \_\_\_\_\_.
36. Derelict hydroelectric power stations could be \_\_\_\_\_ in the future.

#### Questions 37 - 40

Using NO MORE THAN THREE WORDS from Reading Passage 3, answer the following questions.

37. What proportion of the world's electricity supply is provided by hydroelectric power?
38. How is the flow rate of a hydroelectric power station quantified?
39. When do high head power plants use surplus electricity to transfer water to a second reservoir?
40. What underwater action can lead to the production of pollution similar to that produced by fossil fuel power stations?

**Help Now Academic Reading 5****READING PASSAGE 1****Questions 1 – 13****Questions 1 - 4**

Reading Passage 1 has 5 paragraphs (A – E). From the list of headings below choose the most suitable headings for paragraphs B – E. Write the appropriate number (i – viii) in boxes 1 – 4 on your answer sheet. NB There are more headings than paragraphs, so you will not use them all.

**Example** Answer

**Paragraph A** iii

- |       |                            |
|-------|----------------------------|
| i.    | Climate Conditions         |
| ii.   | Solutions from the Air     |
| iii.  | Fire Starters              |
| iv.   | Battling the Blaze         |
| v.    | The Lie of the Land        |
| vi.   | Rain – The Natural Saviour |
| vii.  | Fuelling the Flames        |
| viii. | Fires and Trees            |

- |    |             |
|----|-------------|
| 1. | Paragraph B |
| 2. | Paragraph C |
| 3. | Paragraph D |
| 4. | Paragraph E |

**Wildfires****A**

Wildfires are usually the product of human negligence. Humans start about 90% of wild fires and lightning causes the other 10%. Regular causes for wildfires include arson, camping fires, throwing away cigarettes, burning rubbish, and playing with fireworks or matches. Once begun, wildfires can spread at a rate of up to 23 kph and, as a fire spreads over a landscape, it could undertake a life of its own – doing different things to keep itself going, even creating other blazes by throwing cinders miles away.

Three components are necessary to start a fire: oxygen, fuel and heat. These three make up “the fire triangle” and fire fighters frequently talk about this when they are attempting to put out blazes. The theory is that if the fire fighters can remove one of the triangle pillars, they can take control of and eventually put out the fire.

**B**

The speed at which wildfires spread depends on the fuel around them. Fuel is any living or dead material that will burn. Types of fuel include anything from trees, underbrush and grassland to houses. The quantity of inflammable material around a fire is known as “the fuel load” and is determined by the amount of available fuel per unit area, usually tons per acre. How dry the fuel is can also influence how fires behave. When the fuel is very dry, it burns much more quickly and forms fires that are much harder to control.

Basic fuel characteristics affecting a fire are size and shape, arrangement and moisture, but with wildfires, where fuel usually consists of the same type of material, the main factor influencing ignition time is the ratio of the fuel’s total surface area to its volume. Because the surface area of a twig is not much bigger than its volume, it ignites rapidly. However, a tree’s surface area is much smaller than its volume, so it requires more time to heat up before ignition.

**C**

Three weather variables that affect wildfires are temperature, wind and moisture. Temperature directly influences the sparking of wildfires, as heat is one of the three pillars of the fire triangle. Sticks, trees and underbrush on the ground receive heat from the sun, which heats and dries these potential fuels. Higher temperatures allow fuels to ignite and burn more quickly and add to the speed of a wildfire’s spread. Consequently, wildfires tend to rage in the afternoon, during the hottest temperatures.

The biggest influence on a wildfire is probably wind and this is also the most unpredictable variable. Winds provide fires with extra oxygen, more dry fuel, and wind also makes wildfires spread more quickly. Fires also create winds of their own that can be up to ten times faster than the ambient wind. Winds can even spread embers that can generate additional fires, an event known as spotting. Winds also change the course of fires, and gusts can take flames into trees, starting a “crown fire”. Humidity and precipitation provide moisture that can slow fires down and



reduce their intensity, as it is hard for fuel to ignite if it has high moisture levels. Higher levels of humidity mean fewer wildfires.

D

Topography can also hugely influence wildfire behaviour. In contrast to fuel and weather, topography hardly changes over time and can help or hamper the spread of a wildfire. The principal topographical factor relating to wildfires is slope. As a rule, fires move uphill much faster than downhill and the steeper the slope, the quicker fires move. This is because fires move in the same direction of the ambient wind, which generally blows uphill. Moreover, the fire can preheat fuel further uphill as smoke and heat rise in that direction. On the other hand, when the fire reaches the top of a hill, it has to struggle to come back down.

E

Each year thousands of fire fighters risk their lives in their jobs. Elite fire fighters come in two categories: Hotshots and Smokejumpers. Operating in 20 man units, the key task of hotshots is to construct firebreaks around fires. A firebreak is a strip of land with all potential fuel removed. As their name suggests, smokejumpers jump out of aircraft to reach smaller fires situated in inaccessible regions. They attempt to contain these smaller fires before they turn into bigger ones. As well as constructing firebreaks and putting water and fire retardant on fires, fire fighters also use "backfires". Backfires are created by fire fighters and burn towards the main fire incinerating any potential fuel in its path. Fire fighters on the ground also receive extensive support from the air with tankers dropping thousands of gallons of water and retardant. Dropped from planes and helicopters, retardant is a red chemical containing phosphate fertilizer, which slows and cools fires.

#### Questions 5 - 9

Using **NO MORE THAN THREE WORDS** from Reading Passage 2, answer the following questions. Write your answers in boxes 5 - 9 on your answer sheet.

5. Complete the last pillar of the fire triangle.

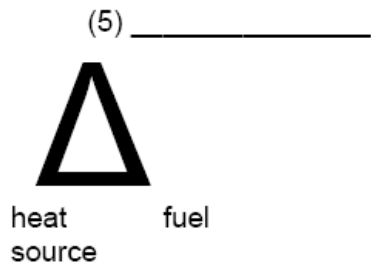

6. What is measured in tons per acre?  
 7. When do wildfires burn at their fiercest?  
 8. What can travel in the wind to create fires at some distance from the initial fire?  
 9. Name a method using an additional fire that fire fighters use to control wild fires.

#### Questions 10 - 13

Complete each of the following statements (Questions 10 - 13) with words taken from Reading Passage 1. Write **NO MORE THAN THREE WORDS** for each answer.

10. The most important factor in how quickly a wildfire catches fire is the surface to volume \_\_\_\_\_.
11. The most significant weather factor to affect wildfires' actions is \_\_\_\_\_.
12. Fires on the tops of trees are known as \_\_\_\_\_.
13. Wildfires usually travel much faster \_\_\_\_\_ because of the typical direction of prevailing winds.

## READING PASSAGE 2

Questions 14 - 27

**PROBLEMS WITH WATER**

Nearly half the world's population will experience critical water shortages by 2025, according to the United Nations (UN). Wars over access to water are a rising possibility in this century and the main conflicts in Africa during the next 25 years could be over this most precious of commodities, as countries fight for access to scarce resources. "Potential water wars are likely in areas where rivers and lakes are shared by more than one country," says Mark Evans a UN worker. Evans predicts that "population growth and economic development will lead to nearly one in two people in Africa living in countries facing water scarcity or what is known as 'water stress' within 25 years." Water scarcity is defined as less than 1,000 cubic metres of water available per person per year, while water stress means less than 1,500 cubic metres of water is available per person per year. The report says that by 2025, 12 more African countries will join the 13 that already suffer from water stress or water scarcity. What makes the water issue even more urgent is that demand for water will grow increasingly fast as larger areas are placed under crops and economic development. Evans adds that "the strong possibility that the world is experiencing climate change also adds to this urgency."

How to deal with water shortages is in the forefront of the battle between environmental activists on the one hand and governments and construction firms on the other. At the recent World Summit on Sustainable Development in Johannesburg activists continued their campaign to halt dam construction, while many governments were outraged about a vocal minority thwarting their plans.

One of the UN's eight millennium development goals is to halve the proportion of people without "sustainable" access to safe drinking water by 2015. How to ensure this happens was one of the big issues of the summit. Much of the text on this was already agreed, but one of the unresolved issues in the implementation plan was whether the goal on water would be extended to cover sanitation. The risks posed by water-borne diseases in the absence of sanitation facilities means the two goals are closely related. Only US negotiators have been resisting the extension of goals to include sanitation due to the financial commitment this would entail. However, Evans says the US is about to agree to this extension. This agreement could give the UN a chance to show that in one key area the world development agenda was advanced in Johannesburg.

But the UN has said Johannesburg was not about words alone, but implementation. A number of projects and funding initiatives were unveiled at the summit. But implementation is always harder, as South Africa has experienced in its water programme. Graham Bennetts, a water official in the South African government explains: "Since the 1994 elections government has provided easy access to water to 7 million people, but extending this to a further 7 million and ensuring this progress is sustainable is one of South Africa's foremost implementation challenges." In South Africa, access to water is defined as 25 litres a person daily, within a distance of 200m from where they live. "Although South Africa's feat far exceeds the UN millennium goal on water supply, severe constraints on local government capacity make a more rapid expansion difficult," says Bennetts.

For some of those who have only recently been given ready access to water, their gains are under threat as the number of cut-offs by municipalities for non-payment rise, says Liane Greef of the Environmental Monitoring Group. Greef is programme manager for Water Justice in southern Africa. Those who have their water supply cut off also automatically forfeit their right to 6000 free litres of water for a family a month under South Africa's "water for all" policy. In the face of continued increases in unemployment, payment for water and other utilities has the potential to fast undo government's high profile feats in delivery since 1994.

It is also the way of ensuring sufficient water supply and its management that will increasingly become a political battleground in South Africa. Water Affairs director-general Mike Muller says South Africa is near the end of its dam-building programme. However, there are big projects proposed elsewhere in southern Africa that could possibly be halted by activists who could bring pressure on funding agencies such as the World Bank. Greef says her group will campaign during the summit against the proposed Skuifraam Dam, which would be built near Franschhoek to supply additional water to Cape Town.

Rather than rely on new dam construction, the city should ensure that water is used wisely at all times rather than only in dry spells, Greef says. Another battleground for her group is over the privatisation of water supply, she says. Water supply, she insists, is best handled in the public interest by accountable government.

There is increasing hope from advances in technology to deal with water shortages. It is agricultural production which takes up about 90% of water consumed for human purposes, says the UN. To lower agricultural demand for water the Sri Lanka-based International Water Management Institute is researching ways of obtaining “more crop per drop” through the development of drought resistant crops, as well as through better water management techniques. One of the institute’s research sites is the Limpopo River basin. According to the institute’s director-general, Frank Rijsbereman, rice growers in China use a quarter of the water a ton of produce to those in South Africa. The institute hopes the “green revolution” in crop productivity will soon be matched by the “blue revolution” in improving water utilisation in agriculture.

**Questions 14 – 21** Match the views (25 – 32) with the people listed below.

14. Water needs to be utilised more prudently by some people.
15. South Africa has almost completed its plans for building dams.
16. Local government has excluded some South African households from getting free water for not meeting their bills.
17. The World Summit in Johannesburg will soon have its aims on hygiene agreed among all participants.
18. Faster development of water supply in South Africa is limited by the facilities of community administrations.
19. Water use is more efficient than in South Africa in some foreign food production.
20. Government should be answerable for water delivery and not private companies.
21. The water question’s importance has been increased due to the risk of global weather temperature rises.

MM	Mike Muller
FR	Frank Rijsbereman
ME	Mark Evans
LG	Liane Greef
GB	Graham Bennets

**Questions 22 - 27**

Read the passage about problems with water again and look at the statements below. Write:

TRUE *if the statement is true*  
 FALSE *if the statement is false*  
 NOT GIVEN *if the information is not given in the passage*

22. Some African countries are currently at war over water resources.
23. A recent report says by 2025 that 25 African countries will suffer from water scarcity alone.
24. Vocal environment activists were arrested at the World Summit.
25. Questions at the World Summit over including water sanitation have not yet been agreed.
26. The World Summit had many good ideas but had little contribution on how to put the ideas into practice.
27. Plants are being introduced that can flourish with little water.

**READING PASSAGE 3****The History of Papermaking in the United Kingdom**

The first reference to a paper mill in the United Kingdom was in a book printed by Wynken de Worde in about 1495. This mill belonged to a certain John Tate and was near Hertford. Other early mills included one at Dartford, owned by Sir John Speilman, who was granted special privileges for the collection of rags by Queen Elizabeth and one built in Buckinghamshire before the end of the sixteenth century. During the first half of the seventeenth century, mills were established near Edinburgh, at Cannock Chase in Staffordshire, and several in Buckinghamshire, Oxfordshire and Surrey. The Bank of England has been issuing bank notes since 1694, with simple watermarks in them since at least 1697. Henri de Portal was awarded the contract in December 1724 for producing the Bank of England watermarked bank-note paper at Bere Mill in Hampshire. Portals have retained this contract ever since but production is no longer at Bere Mill.

There were two major developments at about the middle of the eighteenth century in the paper industry in the UK. The first was the introduction of the rag engine or hollander, invented in Holland sometime before 1670, which replaced the stamping mills, which had previously been used, for the disintegration of the rags and beating of the pulp. The second was in the design and construction of the mould used for forming the sheet. Early moulds had straight wires sewn down on to the wooden foundation, this produced an irregular surface showing the characteristic "laid" marks, and, when printed on, the ink did not give clear, sharp lines. Baskerville, a Birmingham printer, wanted a smoother paper. James Whatman the Elder developed a woven wire fabric, thus leading to his production of the first woven paper in 1757.

Increasing demands for more paper during the late eighteenth and early nineteenth centuries led to shortages of the rags needed to produce the paper. Part of the problem was that no satisfactory method of bleaching pulp had yet been devised, and so only white rags could be used to produce white paper. Chlorine bleaching was being used by the end of the eighteenth century, but excessive use produced papers that were of poor quality and deteriorated quickly. By 1800 up to 24 million pounds of rags were being used annually, to produce 10,000 tons of paper in England and Wales, and 1000 tons in Scotland, the home market being supplemented by imports, mainly from the continent. Experiments in using other materials, such as sawdust, rye straw, cabbage stumps and spruce wood had been conducted in 1765 by Jacob Christian Schäffer. Similarly, Matthias Koops carried out many experiments on straw and other materials at the Neckinger Mill, Bermondsey around 1800, but it was not until the middle of the nineteenth century that pulp produced using straw or wood was utilised in the production of paper.

By 1800 there were 430 (564 in 1821) paper mills in England and Wales (mostly single vat mills), under 50 (74 in 1823) in Scotland and 60 in Ireland, but all the production was by hand and the output was low. The first attempt at a paper machine to mechanise the process was patented in 1799 by Frenchman Nicholas Louis Robert, but it was not a success. However, the drawings were brought to England by John Gamble in 1801 and passed on to the brothers Henry and Sealy Fourdrinier, who financed the engineer Henry Donkin to build

the machine. The first successful machine was installed at Frogmore, Hertfordshire, in 1803. The paper was pressed onto an endless wire cloth, transferred to a continuous felt blanket and then pressed again. Finally it was cut off the reel into sheets and loft dried in

the same way as hand made paper. In 1809 John Dickinson patented a machine that that used a wire cloth covered cylinder revolving in a pulp suspension, the water being removed through the centre of the cylinder and the layer of pulp removed from the surface by a felt covered roller (later replaced by a continuous felt passing round a roller). This machine was the forerunner of the present day cylinder mould or vat machine, used mainly for the production of boards. Both these machines produced paper as a wet sheet, which require drying after removal from the machine, but in 1821 T B Crompton patented a method of drying the paper continuously, using a woven fabric to hold the sheet against steam heated drying cylinders. After it had been pressed, the paper was cut into sheets by a cutter fixed at the end of the last cylinder.

By the middle of the nineteenth century the pattern for the mechanised production of paper had been set. Subsequent developments concentrated on increasing the size and production of the machines. Similarly, developments in alternative pulps to rags, mainly wood and esparto grass, enabled production increases. Conversely, despite the increase in paper production, there was a decrease, by 1884, in the number of paper mills in England and Wales to 250 and in Ireland to 14 (Scotland increased to 60), production being concentrated into fewer, larger units. Geographical changes also took place as many of the early mills were small and had been situated in rural areas. The change was to larger mills in, or near, urban areas closer to suppliers of the raw materials (esparto mills were generally situated near a port as the raw material was brought in by ship) and the paper markets.

#### Questions 28 - 34

Do the following statements agree with the views of the writer of the reading passage on *The History of Papermaking in the U.K.*? Write:

- YES *if the statement agrees with the writer*  
 NO *if the statement doesn't agree with the writer*  
 NOT GIVEN *if it is impossible to say what the writer thinks about this*

28. The printing of paper money in the UK has always been done by the same company.
29. Early paper making in Europe was at its peak in Holland in the 18th century.
30. 18th Century developments in moulds led to the improvement of a flatter, more even paper.
31. Chlorine bleaching proved the answer to the need for more white paper in the 18th and 19th centuries.
32. The first mechanised process that had any success still used elements of the hand- made paper-making process.
33. Modern paper making machines are still based on John Dickinson's 1809 patent.
34. The development of bigger mills near larger towns was so that mill owners could take advantage of potential larger workforces.

#### Questions 35 - 40

Match the events (35 – 40) with the dates (A - G) listed below.

35. Invention of the rag engine.
36. A new method for drying paper patented.
37. First successful machine for making paper put into production.
38. Manufacture of the first woven paper.
39. Watermarks first used for paper money.
40. The first machine for making paper patented.

DATES	A 1803	B 1757	C 1821	D 1697
	E 1799	F 1670	G 1694	

**Help Now Academic Reading 6**  
**READING PASSAGE 1**

Questions 1 - 14

**Amber - Frozen Moments in Time**

Amber has a deep fascination both for ordinary people as a gem and for the scientist for whom it provides a glimpse into the past, a window into history. The majority of amber which has been discovered and studied originates in the Cenozoic Era. The earlier Mesozoic which consists of the Cretaceous, Jurassic and Triassic periods has also produced amber but in smaller and scarcer quantities due to its much older age. One of the problems associated with Mesozoic amber is the level of degradation it undergoes. Ancient fossil resin can be badly affected by oxidation, erosion, excessive heat and pressure.

Amber begins as resin exuded from trees millions of years ago possibly to protect themselves against fungal or insect attack or as a by-product of some form of growth process. Most known deposits of amber come from various tree species which are now extinct. Baltic amber was produced by a giant tree called *Pinites succinifer*, a tree sharing many characteristics of the currently living genus *Pseudolarix*. The true reason for this resin discharge from various species of trees is not fully understood. Scientists have theorised that it also could be a form of desiccation control, an aid to attract insect pollinators or even a reaction to storm or weather damage.

The resin from the trees needs to go through a number of stages in order to become amber. The first stage involves the slow cross chain linking of the molecular structure within the resin, a kind of polymerisation. This makes the resin hard but easily broken compared to its original state of being soft and plastic. Once it is in this state, the resin can be called copal. Following the polymerisation the next stage is the evaporation of volatile oils inside the copal. The oils, called turpenes, slowly permeate out of the amber. This second stage may take millions of years before the process turns the copal into something approaching the structure of amber. It is speculated that either one or both of these stages in the formation of amber must take place in an anaerobic environment or it may have to sustain a period of immersion in sea water. Amber which is exposed to air for several years undergoes oxidation which causes a distinct darkening and crusting of the gem's surface producing over many years tiny splinters and shards.

The chemical structure of amber is not consistent, not even within a single fragment, let alone a single deposit. Consequently numerous chemical formulas have been attributed to it. The reason for this wide variation is simply because amber is not a true mineral; it is an organic plastic with variable mixtures. Some aspects of amber are fairly consistent though. On Moh's scale of hardness it lies between 2 and 2.5. It has a refraction index of 1.54 and a melting point between 150 - 180°C. The colour range is extremely varied, ranging from near white (osseous) through all shades of yellow, brown and red. There are even examples of blue and green amber. Blue - green amber is thought to have two possible causes: either the permeation of raw resin by mineral deposits present in the soil into which it fell, or the settling of volcanic dust and ash onto the resin when it was first secreted.

One of the most exciting and interesting aspects of amber are the inclusions, both flora and fauna, which are found within it. The most frequent inclusions to be found in amber, particularly Baltic, are examples of the order Diptera or true flies. These tiny flies would have lived on the fungus growing on the rotting vegetation of the amber forest of which no doubt there was enough to support an enormous population. Occasionally a small lizard will be found trapped and encased in amber, particularly from the Dominican Republic deposits. The American Natural History Museum has a famous example of a 25,000,000 year old gecko. Another unusual find is the remains of a frog discovered in a piece mined in the Dominican Republic. At first it was thought to be just one animal with some tissue preserved. The

distinct shape of the frog can be seen but most of the flesh has deteriorated and several bones are exposed, some broken. Under closer scrutiny a count of the bones suggests that this particular frog must have had at least 6 legs. Palaeontologists speculate that a bird that ate the frogs may have had a feeding site, perhaps on a branch directly above an accumulating pool of resin; hence the numerous bones present. The complete frog was perhaps an unlucky drop by the bird when it alighted on the branch. Mammalian hair can also infrequently be found trapped as tufts or single strands. When found in the Baltic area, hair in amber is often attributed to sloths that lived within the ancient forest. Resin in the process of hardening usually develops a skin whilst the interior is still soft. Occasionally amber of this nature has impressions stamped on its surface and thus becomes a trace fossil. For instance the clear impression of a cat's paw has been found on a piece of amber found in the Baltic area.

The faking of inclusions in amber has been a major cottage industry since the earliest times. Gum is melted gently and suitable inclusions placed into the matrix; this is frequently some kind of colourful insect. Artificial colour is always a dead give away of a bogus amber fossil.

#### Questions 1 - 4

Read the passage *Amber - Frozen Moments in Time* again and look at the statements below. Write:

TRUE *if the statement is true*  
 FALSE *if the statement is false*  
 NOT GIVEN *if the information is not given in the text*

1. Both animal and plant life have been found trapped in amber.
2. Theorists claim that amber must be submerged at some point during its formation process.
3. It's common to find impressions of animals made on the skin of amber while it was hardening.
4. There are two theories for how amber can develop different colours.

#### Questions 5 - 8

Complete the following statements with the best ending from the box on the next page

Write the appropriate letters A - G in boxes 5 - 8 on your answer sheet.

5. For the most part Baltic amber found today was originally created by plant life which...
6. The faking of encasing things in amber is something which...
7. Prehistoric decaying forests provided food which...
8. Amber is a natural material which...

A ... grew to a great height all over the world.  
 B ... takes place in small houses.  
 C ... entrapped flies would have fed on.  
 D ... can be spotted by the colour.  
 E ... happened only in the Baltic area.  
 F ... produced gases conducive to amber formation.  
 G ... has a broad diversity in its chemical formula.

#### Questions 9 - 11

According to the text which THREE of the following are NOT given as possible reasons for the production of the resin by trees which later forms amber? Choose THREE letters (A – H) and write them in boxes 9 – 11 on your answer sheet.

- A. A defence system
- B. Changes in the molecular structure of the tree
- C. A development side-effect
- D. An effect of the Baltic weather
- E. A way of dealing with water loss
- F. The result of oxidisation
- G. Part of the reproduction process
- H. A result of damage

**Questions 12 – 14**

Complete the summary below describing the amber formation process. NB There are more words than spaces, so you will not use them all.

**SUMMARY**

The formation of amber goes through various stages of which at least one it has been theorised will need the absence of air. Starting as a viscous (12) \_\_\_\_\_ from a tree, the malleability changes as the material becomes (13) \_\_\_\_\_ with a modification of its structure at the molecular level. The next stage takes place over a long time as turpenes seep out of the material leaving an amber-like material which must undergo further degradation from exposure to (14) \_\_\_\_\_ before it can finally be recognised as what we know as amber today.

tough secretion	evaporation sea water	polymers oxygen expansion	soft brittle
--------------------	--------------------------	------------------------------	-----------------

**READING PASSAGE 2****Questions 15 - 26****The Death of the Wild Salmon**

The last few decades have seen an enormous increase in the number of salmon farms in countries bordering the north Atlantic. This proliferation is most marked in two countries famous for their salmon, Norway and Scotland. Salmon farming in Norway and Scotland has expanded to become a major industry and as the number of farmed salmon has exploded, the population of its wild relatives has crashed. The rivers of these countries that used to have such great summer runs of fish every season that they used to attract thousands of anglers from all over the world are now in perilous decline. Recently Truls Halstensen, a Norwegian fishing writer, wrote that his local river, the Driva, where he used to be able to catch five or more fish of over 20 pounds weight in a morning, is now almost totally fishless.

The link between the increase in farmed salmon and the decline in the wild population is hotly disputed. Environmentalists claim that the increase in farming has affected wild salmon and the sea environment in various ways. Firstly it is claimed that the mass escapes of farmed fish present a grave threat to the gene pool of wild salmon stocks. Escapees breed less successfully than wild salmon but the young of the escapees, known as parr, breed aggressively and can produce four times more successfully than their wild counterparts. The parr bred by escapees also become sexually active far sooner than wild salmon and fertilise more eggs. The farmed salmon are therefore genetically changing the wild salmon stocks. Jeremy Read, director of the Atlantic Salmon Trust points out that: "the major problem of interbreeding is that it reduces a population's fitness and ability to survive. Native salmon have evolved to meet the circumstances and habitat of sea and river life. Farm fish are under very different selection pressures in an artificial habitat. This could leave the world with a north Atlantic salmon which could not survive in its native conditions." The huge increase in sea lice in coastal waters is another growing problem. Sea lice thrive in salmon farm conditions and their increase in numbers means that wild salmon and other fish entering waters where there are farms can fall prey to the lice.

Another difficulty and one of the most worrying side effects of the salmon farm industry is that salmon farmers cannot function without vast quantities of tiny sea creatures to turn into food pellets to feed their stock. Lars Tenson of the Norwegian Fishermen's association complains that "the huge quantities of small fish caught by industrial trawlers is helping to strip fishing grounds of the small fish and of other species, including wild salmon, that depend on the feed fish."

Fish farms are also being blamed for increasing levels of nitrogen in the ocean. Over the last 2 years there have been 26 effluent leaks involving nitrogen-rich fish droppings. Naturally occurring algae feed on this and grow into large toxic blooms that kill most other marine life. Even legal chemicals used in farms, such as those used to combat the sea lice, can unbalance micro-organism populations, affecting the other organisms that feed on them. Kevin Dunnon, director of



FEO Scotland, has warned that “using inappropriate chemicals and medicines has the potential to do real environmental damage... We will prosecute if we find enough evidence.”

In spite of the evidence that farming is harming fish populations, fish farmers are adamant that they are not responsible. Nick Jury insists that “algal blooms and the decline in fish stocks have occurred naturally for decades because of a wide range of unrelated and more complex factors.” Jury feels that fish farms are being made a scapegoat for lack of government control of fishing.

Overfishing is a major problem that affects salmon stocks and not just salmon. A combination of high trawler catches, net fishing at estuaries, sport fishing and poaching have all led to stocks of wild salmon diminishing. The UK government likes to think that this problem has been recognized and that the roots of the problems have been attacked by laws passed by them. Fishermen, at sea and in estuaries, have been set quotas and many salmon rivers have been closed to fisherman. Poachers are more difficult to control but their effect is not as marked as that of the fishermen. Angus Kilrie of the NASF feels that the efforts have been wasted: “Legislation has merely scratched the surface. Not enough money has been forthcoming to compensate fishermen and the allowances have been set too high.”

The fate of the wild Atlantic salmon is anybody’s guess. Farmers and governments seem unworried, environmentalists fear the worst. Wild Scottish salmon stocks this year have actually gone up this year which is heralded by the UK’s fisheries department as a result of their policies. Paul Knight, Director of the Salmon and Trout Fishing Association has stated that he is “delighted with the upturn in numbers this year.” He adds the warning though that “there are still significant threats to salmon stocks and that it is important not to take our eye off the ball.” Statistics though can always be interpreted in different ways. All issues concerning the health of the wild north Atlantic salmon need to continue to be addressed in order to protect the viability of future runs.

#### Questions 15 – 21

Match the opinions or statements (15 – 21) with the people who expressed or said them listed below.

15. Says farming cannot be blamed for the salmon stock collapse.
16. Claims the demand for feed for salmon farms is destroying the natural food for other types of fish.
17. Says that efforts must be maintained to protect the salmon.
18. Gives an example from his local area.
19. States that measures taken to stop overfishing are not adequate.
20. Says salmon could soon be genetically incapable of continuing to exist.
21. Threatens legal action against farms that misuse chemicals.

JR Jeremy Read  
 PK Paul Knight  
 AK Angus Kilrie  
 TH Truls Halstensen  
 KD Kevin Dannon  
 NJ Nick Jury  
 LT Lars Tennson

#### Questions 22 - 26

Complete each of the following statements (Questions 22 - 26) with words taken from Reading Passage 2. Write NO MORE THAN THREE WORDS for each answer.

22. The connection between the increase in the salmon raised on fish farms and the drop in the naturally raised salmon is fiercely\_\_\_\_\_.
23. The \_\_\_\_\_of farmed salmon reproduce in larger numbers and more effectively than their wild equivalent.
24. Fishing by \_\_\_\_\_ has led to a huge reduction in the numbers of smaller fish which other larger fish use as food.
25. Fish waste matter which escapes into the water is used for food by \_\_\_\_\_ which accelerates their growth leading to the death of other aquatic organisms.
26. The British government has tried to control fishing at sea and at river mouths by allocating specific \_\_\_\_\_ for netters and fishermen.

## READING PASSAGE 3

Questions 27 - 40

The Can – A Brief History Lesson

A

The story of the can begins in 1795 when Nicholas Appert, a Parisian, had an idea: why not pack food in bottles like wine? Fifteen years later, after researching and testing his idea, he published his theory: if food is sufficiently heated and sealed in an airtight container, it will not spoil. In 1810 Peter Durand, an Englishman, wanted to surpass Appert's invention, so he elected to try tin instead of glass. Like glass, tin could be sealed airtight but tin was not breakable and was much easier to handle. Durand himself did no canning, but two other Englishmen, Bryan Donkin and John Hall, used Durand's patent. After experimenting for more than a year, they set up a commercial canning factory and by 1813 they were sending tins of food to British army and navy authorities for trial.

B

Perhaps the greatest encouragement to the newborn canning industry was the explosion in the number of new colonial territories. As people and goods were being transported to all parts of the world, the can industry itself was growing in new territories. Englishmen who emigrated to America brought their newfound knowledge with them. One of these was Thomas Kensett, who might fairly be called the father of the can manufacturing industry in the United States. In 1812 he set up a small plant on the New York waterfront to can the first hermetically sealed products in the United States.

C

Just before the Civil War, a technical advance by canners enabled them to speed up production. Adding calcium chloride to the water in which cans were cooked raised the water temperature, speeding up the canning process. Also for almost 100 years, tin cans were made by artisans by hand. It was a laborious process, requiring considerable skill and muscle. As the industrial revolution took hold in the United States, the demand for cans increased and machines began to replace the artisans' handiwork. A good artisan could make only 10 cans a day. True production progress in can making began in 1922, when American engineers perfected the body making process. New methods soon increased production of cans to as many as 250 a minute.

D

As early as 1940, can manufacturers began to explore the possibility of adapting cans to package carbonated soft drinks. The can had to be strengthened to accommodate higher internal can pressures created by carbonation (especially during warm summer months), which meant increasing the thickness of the metal used in the can ends. Another concern for the new beverage can was its shelf life. Even small amounts of dissolved tin or iron from the can could impair the drinking quality of drinks. Also the food acids, including carbonic, citric and phosphoric, in soft drinks presented a risk for the rapid corrosion of exposed tin and iron in the can. At this point the can was upgraded by improving the organic coatings used to line the inside. The can manufacturers then embarked on a program of material and cost savings by reducing both the amount of steel and the amount of coating used in can making. These efforts were in part inspired by a new competitor - aluminium.

E

Beverage cans made from aluminum were first introduced in 1965. This was an exciting innovation for the packaging industry because the aluminum can was made with only two pieces - a body and an end. This made production easier. Some of the reasons for the aluminum can's acceptance were its ductility, its support of carbonation pressure, its lighter weight and the fact that aluminum does not rust. Both steel and aluminum cans used an easy-open end tab but the aluminum tab was much easier to make. Perhaps the most critical element in the aluminum can's market success was its recycling value. Aluminum can recycling excelled economically in the competition with steel because of the efficiencies aluminum cans realized in making new cans from recycled materials compared with 100 percent virgin aluminum. Steel did not realize similar economies in the recycling process.

F

Prior to 1970, can makers, customers and consumers alike were unaware of the impact that the mining and manufacturing of steel or aluminium had on the environment. The concept of natural

resource preservation was not an issue of great importance and the low growth of population during these early years further de-emphasized concerns for resource depletion. Both industries, however, came to realize the importance of reducing their impact on the environment in the late 1960s and early 1970s as a new environmentally conscious generation emerged. Manufacturers began to recognize the economics of recycling, namely lower manufacturing costs from using less material and less energy. By the 1980s and 1990s, recycling had become a way of life. Aluminum can recycling has become a billion-dollar business and one of the world's most successful environmental enterprises. Over the years, the aluminum can has come to be known as America's most recyclable package, with over 60 percent of cans being recycled annually

**G**  
 Advances in can manufacturing technology have also brought us lighter aluminum cans. In 1972, one pound of aluminum yielded only 21.75 cans. Today, by using less material to make each can, one pound of aluminum makes approximately 32 cans - a 47 percent improvement. Just the lightening of can ends makes a huge difference. When you multiply the savings by the 100 billion cans that are made each year, the weight and savings are phenomenal - over 200 million pounds of aluminum!

**Questions 27 - 32**

The reading passage on *The Can - A Brief History Lesson* has 7 paragraphs A – G. From the list of headings below choose the most suitable headings for paragraphs B – G. NB There are more headings than paragraphs, so you will not use them all.

- |       |                                    |
|-------|------------------------------------|
| i.    | The Invention of the Aluminium Can |
| ii.   | Technological Breakthroughs        |
| iii.  | Canning and the Beer Industry      |
| iv.   | The Invention                      |
| v.    | Canning and War                    |
| vi.   | Further Manufacturing Advances     |
| vii.  | Problems with Spoiled Contents     |
| viii. | Expansion of the Industry          |
| ix.   | Today's Uses for Canning           |
| x.    | Drinks Canning                     |
| xi.   | Cans and The Environment           |

- |                 |
|-----------------|
| 27. Paragraph B |
| 28. Paragraph C |
| 29. Paragraph D |
| 30. Paragraph E |
| 31. Paragraph F |
| 32. Paragraph G |

**Questions 33 - 38**

Below are two lists. The first list (questions 33- 38) is a list of dates of events in Reading Passage. The second list (A - G) is a list of the events. Match the year with the correct event in the history of the can. One of the dates and one of the events are matched as an example.

<i>Example</i>	1810	<i>Answer</i>	<b>E</b>
QUESTION	DATE		
33.	1922		
34.	1812		
35.	1813		
36.	1965		
37.	1813		
38.	1940		

**EVENTS**

- A. Mass production techniques revolutionized the canning process.
- B. Tinned food was tested by military authorities.
- C. Today's canning material was first introduced.
- D. The first American canning factory was opened.
- E. Tin was used in the canning process for the first time.
- F. The canning of fizzy drinks began.
- G. The first business canning plant was opened.

**Questions 39 and 40**

- TRUE *if the statement is true*
- FALSE *if the statement is false*
- NOT GIVEN *if the information is not given in the text*

- 39. Recycling has helped reduce manufacturing overheads.
- 40. Aluminium can production costs have fallen by nearly 50% since 1972.

**Help Now Academic Reading 7**  
**READING PASSAGE 1**

Questions 1 - 13

**The Canals of De Lesseps**

Two of the most spectacular engineering feats of the last 200 years were of the same type though thousands of miles apart. They were the construction of the Suez and Panama canals. The Panama Canal joins the Pacific and Atlantic oceans while the Suez joins the Red Sea (Indian Ocean) and the Mediterranean (Atlantic Ocean). Both offer ships huge savings in time and mileage. For example, a nine hour trip on the Panama Canal would save a total of 18,000 miles on a trip from New York to San Francisco. Amazingly enough the same French engineer, Ferdinand de Lesseps, played a major part in the construction of both.

The history of the Panama Canal goes back to 16th century with a survey of the isthmus and a working plan for a canal ordered by the Spanish government in 1529. In the 18th century various companies tried and failed to construct the canal but it wasn't until 1880 that a French company, organized by Ferdinand Marie de Lesseps, proposed a sea level canal through Panama. He believed that if a sea level canal worked when constructing the Suez Canal, it must work for the Panama Canal. Finally the Panama Canal was constructed in two stages. The first between 1881 and 1888, the work being carried out by the French company headed by de Lesseps, and secondly, the work by the Americans which eventually completed the canal's construction between 1904 and 1914. The French company ran out of money and an attempt was unsuccessful to raise funds by applying to the French government to issue lottery bonds which had been successful during the construction of the Suez Canal when that project was at the point of failure through lack of money. The French problems stemmed from their inability to create a viable solution to the differences in tidal changes in the Pacific and Atlantic Oceans. There is a tidal range of 20 feet at the Pacific whereas the Atlantic range is only about 1 foot. The Americans proposed that a tidal lock should be constructed at Panama which solved the problem and reduced excavation by an enormous amount. When construction was finally finished, the canal ran through various locks, four dams and ran the lengths of two naturally occurring lakes, the 32 mile Gatun Lake and the 5 mile Miraflores Lake.

When the US took on finishing the canal they and the new state of Panama signed the Hay-Bunau-Varilla treaty, by which the United States guaranteed the independence of Panama and secured a perpetual lease on a 10 mile strip for the canal. Panama was to be compensated by an initial payment of \$10 million and an annuity of \$250,000, beginning in 1913. On December 31st 1999 United States transferred the 51 mile Panama Canal, the surrounding Panama Canal Area and the income back to the Panamanian government.

The idea of a canal linking the Mediterranean to the Red Sea also dates back to ancient times. Unlike the modern canal, earlier ones linked the Red Sea to the Nile, therefore forcing the ships to sail along the River on their journey from Europe to India. It consisted of two parts: the first linking the Gulf of Suez to the Great Bitter Lake, and the second connecting the Lake to one of the branches in the Nile Delta that runs into the Mediterranean. The canal remained in good condition during the Ptolemaic era, but fell into disrepair afterwards and was completely abandoned upon the discovery of the trade route around Africa.

It was Napoleon's engineers who, around 1800 AD, revived the idea of a shorter trade route to India via a Suez canal. However, the calculation carried out by the French engineers showed a difference in level of 10 meters between both seas. If constructed under such circumstances, a large land area would be flooded. Later the digging of the canal was undertaken by the Ferdinand de Lesseps, who showed the previous French sea height estimates to be incorrect and that locks or dams were not needed.

In 1859, Egyptian workers started working on the construction of the canal in conditions described by historians as slave labor, and the project was completed around 1867. The canal is 163 km long, and has a width of a minimum of 60 metres. The canal cuts through three lakes, Lake

Manzala in the north, Lake Timsah in the middle and the Great Bitter Lake further south. The largest, the Great Bitter Lake makes up almost 30 km of the total length. The canal is extensively used by modern ships as it is the fastest crossing from the Atlantic Ocean to the Indian Ocean.

In July 1956 the Egyptian president Nasser announced the nationalization of the canal in response to the British, French and American refusal for a loan aimed at building the Aswan High Dam on the Nile. The revenue from the canal, he argued, would help finance the High Dam project. Since then the Egyptians have controlled the canal. Today, approximately 50 ships cross the canal daily and the cities and beaches along the Great Bitter Lake and the canal serve as a summer resort for tourists.

### Questions 1- 8

Use the information in the text to match the statements (1 – 8) with the canal references (A – D). Write:

- A. if the statement refers to the Panama Canal.
- B. if the statement refers to the Suez Canal.
- C. if the statement refers to both the Panama Canal and the Suez Canal.
- D. If the statement refers to neither the Panama Canal and the Suez Canal.

1. The surface of the whole canal is at sea level.
2. The canal's construction had financial problems.
3. Dams had to be built to construct the canal.
4. The canal generates money for the country it passes through.
5. Previous labour conditions of construction workers at the canal have been criticised.
6. The canal's construction was held up by war.
7. The canal is also a holiday destination.
8. Over half the canal is within a single lake.

### Questions 9 - 13

Read the passage The Canals of de Lessep's again and look at the statements below. Write:

- TRUE if the statement is true  
 FALSE if the statement is false  
 NOT GIVEN if the information is not given in the passage

9. De Lessep's Suez Canal construction theories were equally successful in the building of the Panama Canal as they were in building the Suez Canal.
10. The decision to use locks in the Panama Canal also saved time doing other activities.
11. The US were not happy about returning the control of the Panama Canal to Panama.
12. The current Suez Canal is the second canal that has joined the Red Sea to the Mediterranean.
13. The British government refused to give assistance in constructing the Suez Canal.

### READING PASSAGE 2

### Questions 14 – 27

### Questions 14 - 19

The reading passage on *The Ozone Hole* has 6 paragraphs (A – F). From the list of headings below (i – ix) choose the most suitable headings for paragraphs A – F. NB There are more headings than paragraphs, so you will not use them all.

- |       |                                 |
|-------|---------------------------------|
| i.    | The Destruction Process         |
| ii.   | How Is Ozone Formed?            |
| iii.  | How Technology Can Help         |
| iv.   | Artificial Emissions            |
| v.    | What Is Being Done?             |
| vi.   | The Function of the Ozone Layer |
| vii.  | Empirical Analysis              |
| viii. | Initial Identification          |
| ix.   | Hospitalisation                 |

- |    |             |
|----|-------------|
| 1. | Paragraph A |
| 2. | Paragraph B |
| 3. | Paragraph C |
| 4. | Paragraph D |
| 5. | Paragraph E |
| 6. | Paragraph F |

## The Ozone Hole

### Paragraph A

Ozone is a bluish gas that is harmful to breathe. Nearly 90% of the Earth's ozone is in the stratosphere and is referred to as the ozone layer. Ozone absorbs a band of ultraviolet radiation called UVB that is particularly harmful to living organisms. Stratospheric ozone is constantly

being created and destroyed through natural cycles. Various ozone depleting substances however, accelerate the destruction processes, resulting in lower than normal ozone levels. Reductions in ozone levels will lead to higher levels of UVB reaching the Earth's surface. The sun's output of UVB does not change; rather, less ozone means less protection, and hence more UVB reaches the Earth. Studies have shown that in the Antarctic, the amount of UVB measured at the surface can double during the annual ozone hole. Laboratory and epidemiological studies demonstrate that UVB causes non melanoma skin cancer and plays a major role in malignant melanoma development. In addition, UVB has been linked to cataracts.

#### Paragraph B

Dramatic loss of ozone in the lower stratosphere over Antarctica was first noticed in the 1970s by a research group from the British Antarctic Survey (BAS) who were monitoring the atmosphere above Antarctica from a research station. Folklore has it that when the first measurements were taken in 1975, the drop in ozone levels in the stratosphere was so dramatic that at first the scientists thought their instruments were faulty. Replacement instruments were built and flown out and it wasn't until they confirmed the earlier measurements, several months later, that the ozone depletion observed was accepted as genuine. Another story goes that the BAS satellite data didn't show the dramatic loss of ozone because the software processing the raw ozone data from the satellite was programmed to treat very low values of ozone as bad readings. Later analysis of the raw data when the results from the British Antarctic Survey team were published, confirmed their results and showed that the loss was rapid and large-scale; over most of the Antarctica continent.

#### Paragraph C

Ozone occurs naturally in the atmosphere. The earth's atmosphere is composed of several layers. We live in the Troposphere, ground level up to about 10km high, where most of the weather occurs such as rain, snow and clouds. Above that is the Stratosphere, an important region in which effects such as the Ozone Hole and Global Warming originate. The layer next to space is the Exosphere and then going inwards there are the Thermosphere and the Mesosphere. Supersonic passenger jets fly just above the troposphere whereas subsonic commercial airliners are usually well in the troposphere. The narrow region between these two parts of the atmosphere is called the Tropopause. Ozone forms a layer in the stratosphere, thinnest in the tropics and denser towards the poles. The amount of ozone above a point on the earth's surface is measured in Dobson units (DU) - typically ~260 DU near the tropics and higher elsewhere, though there are large seasonal fluctuations. It is created when ultraviolet radiation in the form of sunlight strikes the stratosphere, splitting oxygen molecules to atomic oxygen. The atomic oxygen quickly combines with further oxygen molecules to form ozone.

#### Paragraph D

The Ozone Hole often gets confused in the popular press and by the general public with the problem of global warming. Whilst there is a connection because ozone contributes to the greenhouse effect, the Ozone Hole is a separate issue. Over Antarctica (and recently over the Arctic), stratospheric ozone has been depleted over the last 15 years at certain times of the year. This is mainly due to the release of man-made chemicals containing chlorine such as CFCs (ChloroFluoroCarbons), but also compounds containing bromine, other related halogen compounds and also nitrogen oxides. CFC's are a common industrial product, used in refrigeration systems, air conditioners, aerosols, solvents and in the production of some types of packaging. Nitrogen oxides are a by-product of combustion processes, for example aircraft emissions.

#### Paragraph E

The ozone depletion process begins when CFCs and other ozone depleting substances are emitted into the atmosphere where winds efficiently mix and evenly distribute the gases. CFCs are extremely stable, and they do not dissolve in rain. After a period of several years natural gases in the stratosphere combine with CFCs and this releases chlorine atoms, halons and methyl bromide. These in turn all release bromine atoms and it is these atoms that actually destroy ozone. It is estimated that one chlorine atom can destroy over 100,000 ozone molecules before it is removed from the stratosphere.

#### Paragraph F

The first global agreement to restrict CFCs came with the signing of the Montreal Protocol in 1987 ultimately aiming to reduce them by half by the year 2000. Two revisions of this agreement have been made in the light of advances in scientific understanding, the latest being in 1992.

Agreement has been reached on the control of industrial production of many halocarbons until the year 2030. The main CFCs will not be produced by any of the signatories after the end of 1995, except for a limited amount for essential uses, such as for medical sprays. The countries of the European Community have adopted even stricter measures. Recognizing their responsibility to the global environment they have agreed to halt production of the main CFCs from the beginning of 1995. It was anticipated that these limitations would lead to a recovery of the ozone layer within 50 years of 2000. The World Meteorological Organisation estimated 2045 but recent investigations suggest the problem is perhaps on a much larger scale than anticipated.

### Questions 20 - 25

Complete the following statements (questions 20 - 25) with the best ending from the box below (A - H) according to the information in the reading passage *The Ozone Hole*. N.B. There are more sentence endings than questions so you will not need to use them all.

20. International agreements will eventually lead to...
21. An apocryphal BAS story cites that equipment was changed to measure...
22. It is a common mistake to associate the Ozone Hole problem with...
23. The thickness of the Ozone layer varies with...
24. The Ozone layer is destroyed by a by product of CFCs reacting with...
25. Common household appliances contribute to...
  - A ...the location of the layer relative to the earth.
  - B ...the discharge of synthetic chemicals into the atmosphere.
  - C ...the satellite orbiting the earth.
  - D ...the normal components of the earth's atmosphere.
  - E ...the apparently anomalous readings taken earlier.
  - F ...the issue of the heating up of the earth's atmosphere.
  - G ...recent investigations into the strength of Dobson Units.
  - H ...the cessation of the release of most CFC gases into the atmosphere.

### Questions 26 and 27

Answer questions 26 and 27 below with reference to the diagram of the earth and its layers of atmosphere at the bottom of the page. Write the appropriate letter (A - E) on your answer sheet.

26. In which atmosphere layer would you find the Ozone layer and hole?
27. In which atmosphere layer would you find a conventional passenger airliner usually flying?

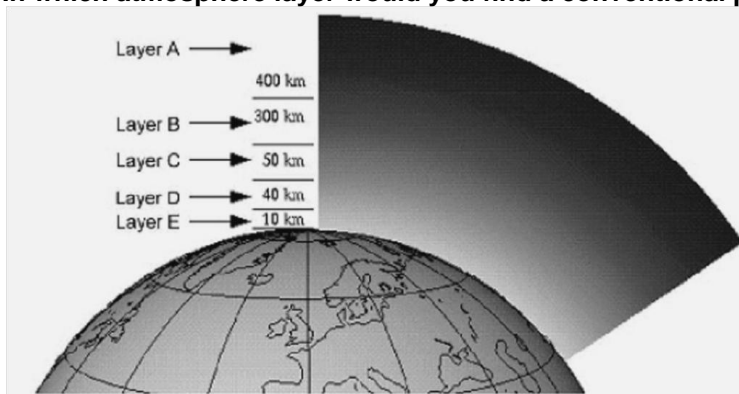

## **READING PASSAGE 3 Questions 28 - 40**

### **OLIVE OIL PRODUCTION**

Olive oil has been one of the staples of the Mediterranean diet for thousands of years and its popularity is growing rapidly in other parts of the world. It is one of the most versatile oils for cooking and it enhances the taste of many foods. Olive oil is the only type of vegetable/fruit oil that can be obtained from just pressing. Most other types of popular oils (corn, canola, etc.) must be processed in other ways to obtain the oil. Another important bonus is that olive oil has proven health benefits. Three basic grades of olive oil are most often available to the consumer: extra

Virgin, Virgin and Olive Oil. In addition to the basic grades, olive oil differs from one country or region to another because of the types of olives that are grown, the harvesting methods, the time of the harvest, and the pressing techniques. These factors all contribute to the individual characteristics of the olive oil.

Olive trees must be properly cared for in order to achieve good economic yields. Care includes regular irrigation, pruning, fertilising, and killing pests. Olives will survive on very poor sites with shallow soils but will grow very slowly and yield poorly. Deep soils tend to produce excessively vigorous trees, also with lower yields. The ideal site for olive oil production is a clay loam soil with good internal and surface drainage. Irrigation is necessary to produce heavy crops and avoid alternate bearing. The site must be free of hard winter frosts because wood damage will occur at temperatures below 15°F and a lengthy spell of freezing weather can ruin any chances for a decent crop. The growing season also must be warm enough so fruits mature before even light fall frosts (usually by early November) because of potential damage to the fruit and oil quality. Fortunately olive trees are very hardy in hot summer temperatures and they are drought tolerant.

The best olive oils hold a certificate by an independent organization that authenticates the stone ground and cold pressed extraction process. In this process, olives are first harvested by hand at the proper stage of ripeness and maturity. Experts feel that hand harvesting, as opposed to mechanical harvesting, eliminates bruising of the fruit which causes tartness and oil acidity. The olives harvested are transferred daily to the mill. This is very important because this daily transfer minimizes the time spent between picking and pressing. Some extra virgin olive oil producers are known to transfer the olives by multi-ton trucks over long distances that expose the fragile fruit to crushing weight and the hot sun, which causes the olives to begin oxidizing and thus becoming acidic. In addition to the time lapse between harvesting and pressing, olive oil must be obtained using mechanical processes only to be considered virgin or extra virgin. If heat and/or chemical processes are used to produce the olive oil or if the time lapse is too long, it cannot be called virgin or extra virgin.

Once at the mill, the leaves are sucked away with air fans and the olives are washed with circulating potable water to remove all impurities. The first step of extraction is mashing the olives to create a paste. The oil, comprising 20% to 30% of the olive, is nestled in pockets within the fruit's cells. The olives are crushed in a mill with two granite millstones rolling within a metal basin. Crushing and mixing the olives releases the oil from the cells of the olive without heating the paste. A side shutter on the mill's basin allows the mixed olive paste to be discharged and applied to round mats. The mats are stacked and placed under the head of a hydraulic press frame that applies downward pressure and extracts the oil. The first pressing yields the superior quality oil, and the second and third pressings produce inferior quality oil. Some single estate producers collect the oil that results from just the initial crushing while many other producers use an additional step to extract more oil. The olive pulp is placed on mats constructed with hemp or polypropylene that are stacked and then pressed to squeeze the pulp. Oil and water filter through the mats to a collection tank below. The water and oil are then separated in a centrifuge.

Regardless of the method used for the first pressing, the temperature of the oil during production is extremely important in order to maintain the distinct characteristics of the oil. If the temperature of the oil climbs above 86°F, it will be damaged and cannot be considered cold-pressed.

The first pressing oil contains the most "polyphenols", substances that have been found to be powerful antioxidants capable of protecting against certain types of disease. The polyphenols are not the only substances in the olive with health-promoting effects, but they are quite unique when compared to other commonly used culinary oils such as sunflower and soy. It is these polyphenols that really set extra virgin olive oils apart from any other oil and any other form of olive oil. The more refined the olive oil is, the smaller the quantity of polyphenols.

The result of the producers' efforts is a cold pressed extra virgin olive oil with high quality standards and organoleptic characteristics, which give the oil its health-protective and aromatic properties.



**Questions 28 - 31**

Choose the appropriate letters A – D that best finish the sentence or best answer the question. .

28. According to the text, which of the following does NOT affect the individual features of olive oils from different regions?
- Picking techniques
  - The date of the picking
  - Olive varieties
  - Access to water
29. According to the text, which of the following is NOT part of olive tree management?
- Careful watering
  - Replanting
  - Killing parasites
  - Feeding
30. According to the text, what is the main danger of frost?
- It kills the olive trees
  - The fruit won't mature
  - Not enough fruit will be produced
  - The olives produced will be small in size
31. According to the text, which of the following does NOT affect the "extra virgin" olive oil certification?
- The temperature of the extraction process
  - The time gap between tree and bottle
  - Which pressing the oil is taken from
  - Using water in the extraction process

**Questions 32 - 34**

Read the passage *Olive Oil Production* again and look at the statements below. Write:

- TRUE *if the statement is true*  
 FALSE *if the statement is false*  
 NOT GIVEN *if the information is not given in the text*

- Olive trees don't need a regular supply of water to survive.
- No other cooking oils apart from olive oil contain polyphenols.
- Damage to olives before they are pressed can affect the taste of the oil.

**Questions 35 – 40**

Using the information in Reading Passage 3, complete the flow chart below. Write your answers in boxes 35 – 40 on your answer sheet. Use NO MORE THAN THREE WORDS from the passage for each answer.

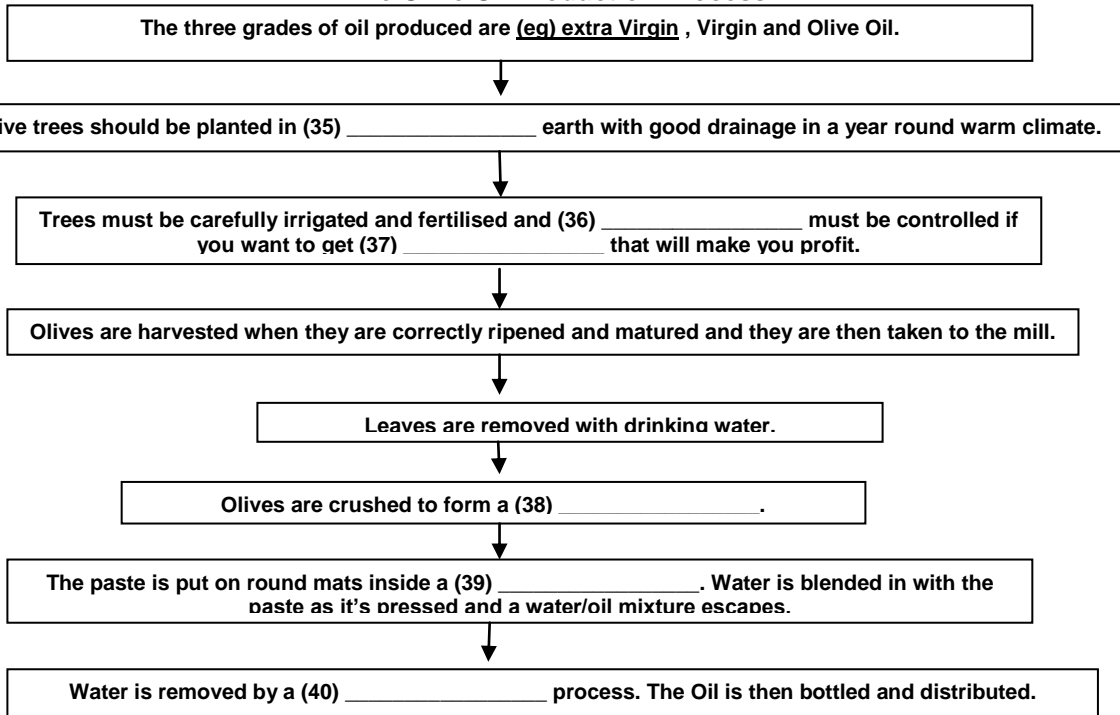
**The Olive Oil Production Process**

**Help Now Academic Reading 8****READING PASSAGE 1****Questions 1 - 13**

Myxomatosis is a highly lethal disease affecting rabbits caused by the myxoma virus. The disease was uncovered in South America in 1896 where it had a devastating effect on the rabbit population there. It was found that it was mainly the European rabbit imported early that century that contracted the disease as resistance had been built up by the local populations.

Up until recently rabbits have been extensively hunted for both their fur and their meat. This activity as well as the presence of other predators such as foxes and feral cats acted in the past to keep down the population of rabbits and man is still the main predator in South American countries. However, in other countries man has had a less and less important role as a predator and has in fact helped to reduce the population of the rabbits' natural predators through habitat destruction, urbanisation and cultivation. These changes have resulted in a precarious balance of the rabbit population in many areas where any factors enhancing rabbit survival can result in a huge population boom. Rabbits compete with livestock and native herbivores for food. They are highly selective grazers that concentrate on the most nutritious plants, including seedlings, and eat them to below ground level. This can change the species composition of pastures and reduce productivity. They act as competition for hares and other herbivores and grazing animals, reducing the agricultural output of the land.

The European wild rabbit was introduced into Australia in 1759 when Thomas Austin imported 24 rabbits from England where it was also an exotic animal, having been introduced from Spain during the Norman conquests. He released the rabbits onto his property for sport hunting. The rabbit spread so rapidly that it reached the Queensland - New South Wales border by 1886. Almost all of the rabbits in Australia are descendants of the 24 original rabbits and are genetically homogenous. This fact beyond all others might be the cause of the spectacular effect the introduction of the virus had on the rabbit population as a whole. The lack of any herbivores capable of competing with the rabbit for food and burrows resulted in the decline of many species of native wildlife. This applied particularly to the small ground-dwelling mammals of the arid lands. This situation was made worse by the lack of a large population of predators able to deal with this new prey. However, to the human population of Australia, all of this was irrelevant next to the economic loss caused by rabbits grazing on pasture used by sheep and other herbivores, reducing the number of sheep capable of grazing per acre, and the loss of wool and revenue thus caused.

It was not until 1950 that myxomatosis was successfully released among Australian rabbits. This occurred after much debate, experimentation of what the effects of such a drastic move would be and political wrangling. After a slow start the initial results fulfilled all expectations with a mortality rate of over 90%. The virus spread most quickly during the summer when the mosquito population was at its maximum, resulting in very successful transmission of the virus between separate colonies. Myxomatosis is accompanied by a profuse ocular discharge as well as a discharge from skin lesions, both of which are rich in virus. These discharges allow transmission of the virus by direct contact. Transmission via the respiratory tract is also possible if rare. Infection does not occur by feeding and therefore there is no faeco-oral transmission.

A wide number of mosquitoes, fleas, ticks, mites and lice have also been shown to be vectors. This allows the spread of the virus to take place between colonies of rabbits and in the case of the fleas, allows rabbits from a different colony to become infected by coming into contact with flea-infested carcasses of rabbits in warrens where all the occupants have been killed by myxomatosis some months previously.

The initial Australian epidemic continued during the next few years, spreading and remaining highly virulent, especially in the summers when the mosquito population was at its highest. Epidemics were often started by the continued inoculation by farmers of the wild rabbit population every summer and spring, a method still used today. However, the capacity for the

virus to survive over the winter favoured a less lethal disease, and this, combined with genetic resistance, has resulted in a much reduced mortality rate, even though sporadic outbreaks of the original virulent virus sometimes occur.

Rabbits which recover from myxomatosis are immune to re-infection for the rest of their lives. Also immune mothers pass passive immunity to their young. However, due to the short lifetimes of rabbits, often little more than a year in the wild, this has little effect in practice. Of more importance has been the in-built genetic immunity of certain rabbits in the population. Survival of these rabbits, combined with their high reproduction rate and the death of the competition, meant that a population of genetically more resistant rabbits was quickly built up.

Today myxomatosis in Australia kills only about 40% of infected rabbits but rabbit numbers are much lower than they would have been in the absence of this disease. However, they still are a major pest in Australia and other methods for their eradication are being investigated.

#### Questions 1 - 5

Look at the following 10 statements A - J. According to Reading Passage 1, FIVE statements are TRUE. The other FIVE statements are either FALSE or the information is not given in the passage. Choose from the appropriate letters A - J which statements are true and write them on your answer sheet for questions 1 - 5. The answers may be written in any order.

- A. Predators helped keep Australian rabbit numbers in check before the population boom.
- B. Rabbits can still infect other rabbits after they have died from myxomatosis.
- C. The rabbit is not a native animal to England.
- D. Rabbits that recover from myxomatosis can still die if they are re-infected.
- E. Enthusiastic support of myxomatosis introduction into Australia ensured that the introduction process went forward quickly.
- F. Selected wild Australian rabbits are injected every year with the myxoma virus.
- G. Discharge from the eyes of infected rabbits contributes to the spread of myxomatosis.
- H. Interbreeding with Asian rabbit breeds has helped boost the Australian rabbits' immunity to myxomatosis.
- I. 60% of Australian rabbits are now unaffected by myxomatosis.
- J. The main reason for releasing myxomatosis into Australia was financial.

#### Questions 6 - 12

Using NO MORE THAN THREE WORDS OR A NUMBER from Reading Passage 1, answer the following questions. Write your answers in boxes 6 - 12 on your answer sheet.

6. Where are humans still the main threat to rabbits?
7. Apart from damage to their natural environment, what TWO other factors have reduced the amount of animals that feed on rabbits?
8. Why were rabbits originally taken to Australia?
9. What are TWO things that rabbits challenge other Australian plant eating animals for?
10. Which Australian raw material was particularly affected by the increase in Australian rabbit numbers?
11. What helped the spread of myxomatosis during the Australian summers?
12. What other factor has united with a more harmless form of the myxoma virus to allow more Australian rabbits to survive myxomatosis infection?

#### Questions 13

From the list below choose the most suitable title for Reading Passage 1. Write the appropriate letter (A - E) in box 13 on your answer sheet

- A. A Threat to Humanity
- B. Australian Diseases
- C. The Disease that Saved Australian Farmers
- D. The Genetics of Australian Rabbits
- E. The Pathology of Rabbit Infections

## READING PASSAGE 2

Questions 14 - 26

**The Cause of the Next Ice Age?**

If you look at a globe, you'll see that the latitude of much of Europe and Scandinavia is the same as that of Alaska and permafrost-locked parts of northern Canada and central Siberia. Yet Europe has a climate more similar to that of the United States than northern Canada or Siberia. It turns out that our warmth is the result of ocean currents that bring warm surface water up from the equator into northern regions that would otherwise be so cold that even in summer they'd be covered with ice. The current of greatest concern is often referred to as the Great Conveyor Belt which includes what we call the Gulf Stream. This is mostly driven by the force created by differences in water temperatures and salinity. The North Atlantic Ocean is saltier and colder than the Pacific. As a result, the warm water of the Great Conveyor Belt evaporates out of the North Atlantic leaving behind saltier waters which are cooled by the cold continental winds off the northern parts of North America. Salty, cool waters settle to the bottom of the sea, most at a point a few hundred kilometres south of the southern tip of Greenland, producing a whirlpool of falling water that's 5 to 10 miles across. This falling column of cold, salt-laden water pours itself to the bottom of the Atlantic, where it forms a great undersea river forty times larger than all the rivers on land combined, flowing south down to and around the southern tip of Africa where it finally reaches the Pacific. Amazingly, the water is so deep and so dense that it often doesn't surface in the Pacific for as much as a thousand years after it first sank in the North Atlantic off the coast of Greenland.

The out-flowing undersea river of cold, salty water makes the level of the Atlantic fractionally lower than that of the Pacific, drawing in a strong surface current of warm, fresher water from the Pacific to replace the outflow of the undersea river. This warmer, fresher water slides up through the South Atlantic, loops around North America where it's known as the Gulf Stream, and ends up off the coast of Europe. By the time it arrives near Greenland, it's cooled off and evaporated enough water to become cold and salty and sink to the ocean floor, providing a continuous feed for that deep-sea river flowing to the Pacific. These two flows - warm, fresher water in from the Pacific, which then grows salty and cools and sinks to form an exciting deep sea river - are known as the Great Conveyor Belt.

Prior to the last decades it was thought that the periods between glaciations and warmer times in North America, Europe, and North Asia were gradual. We knew from the fossil record that the Great Ice Age period began a few million years ago and during those years there were times when for hundreds or thousands of years North America, Europe, and Siberia were covered with thick sheets of ice year round. In between these icy times, there were periods when the glaciers thawed, bare land was exposed, forests grew, and land animals (including early humans) moved into these northern regions. Most scientists figured the transition time from icy to warm was gradual, lasting dozens to hundreds of years and nobody was sure exactly what had caused it. Recently however, scientists have been shocked to discover that the transitions from ice age-like weather to contemporary-type weather usually took only two or three years. Something was flipping the weather of the planet back and forth with a rapidity that was startling.

What brought on this sudden effect was that the warm-water currents of the Great Conveyor Belt had shut down. Once the Gulf Stream was no longer flowing, it only took a year or three for the last of the residual heat held in the North Atlantic Ocean to dissipate into the air over Europe and then there was no more warmth to moderate the northern latitudes. When the summer stopped in the north, the rains stopped around the equator. At the same time that Europe was plunged into an Ice Age, the Middle East and Africa were ravaged by drought and wind-driven firestorms. If the Great Conveyor Belt, which includes the Gulf Stream, were to stop flowing today, the result would be sudden and dramatic. Winter would set in for the eastern half of North America and all of Europe and Siberia and never go away.

Within three years, those regions would become uninhabitable and nearly two billion humans would starve, freeze to death or have to relocate. Civilization as we know it probably couldn't withstand the impact of such a crushing blow.

Most scientists involved in research on this topic agree that the culprit is global warming, which melts the icebergs on Greenland and the Arctic icepack and thus flushes cold, fresh water down into the Greenland Sea from the north diluting its salinity. When a critical threshold is reached, the climate will suddenly switch to an ice age that could last minimally 700 or so years, and maximally 100,000 years. No one knows when it will happen but what's almost certain is that if nothing is done about global warming, it will happen sooner rather than later.

#### Questions 14 - 18

Read the passage *The Cause of the Next Ice Age?* again and look at the statements below.

In boxes 14 - 18 on your answer sheet write:

TRUE if the statement is true  
 FALSE if the statement is false  
 NOT GIVEN if the information is not given in the text

14. Another name for the Great Conveyer Belt is the better known name the Gulf Stream.
15. The surface of the Atlantic Ocean is higher than the surface of the Pacific Ocean.
16. The last time the Great Conveyer Belt shut down it caused the deaths of thousands.
17. The arrival of cooler water in the Pacific Ocean affects the weather there too.
18. Global warming has caused the North Atlantic Ocean to become less salty.

#### Questions 19 - 23

Complete each of the following statements (Questions 19 - 23) with words taken from Reading Passage 2. Write **NO MORE THAN THREE WORDS** for each answer.

19. The author points out the reason why Europe is not \_\_\_\_\_ like other countries of the same latitude.
20. The author likens the north – south flow of the Great Conveyer Belt to a \_\_\_\_\_.
21. Scientist can date the last great Ice Age thanks to \_\_\_\_\_.
22. Lately there has been a \_\_\_\_\_ discovery that the change from today's temperate style weather to ice age weather was in fact a fast change.
23. The author identifies the \_\_\_\_\_ for the possible shutting down of the Great Conveyer Belt as being global warming.

#### Questions 24 - 26

Using **NO MORE THAN THREE WORDS OR A NUMBER** from Reading Passage 2, answer the following questions. Write your answers in boxes 24 - 26 on your answer sheet.

24. What do the sinking waters create on the surface of the North Atlantic Ocean?
25. How long can it take for water leaving the surface near Greenland to travel through the Great Conveyer Belt to the surface of the Pacific Ocean?
26. If the Great Conveyer Belt stopped, what would be the maximum amount of time for it to stop heating northern Europe?

#### **READING PASSAGE 3**

#### **Questions 27 - 40**

### **Malaria**

**A**

Approximately 300 million people worldwide are affected by malaria and between 1 and 1.5 million people die from it every year. Previously extremely widespread, malaria is now mainly confined to Africa, Asia and Latin America. The problem of controlling malaria in these countries is aggravated by inadequate health structures and poor socio-economic conditions. The situation has become even more complex over the last few years with the increase in resistance to the drugs normally used to combat the parasite that causes the disease.

**B**

Malaria is caused by protozoan parasites of the genus Plasmodium. Four species of Plasmodium can produce the disease in its various forms: plasmodium falciparum, plasmodium vivax, plasmodium ovale and plasmodium malaria. Plasmodium falciparum is the most widespread and dangerous of the four: untreated it can lead to fatal cerebral malaria. Malaria parasites are transmitted from one person to another by the female anopheline mosquito. The males do not transmit the disease as they feed only on plant juices. There are about 380 species of anopheline mosquito, but only 60 or so are able to transmit the parasite. Their sensitivity to insecticides is also highly variable.

**C**

Plasmodium develops in the gut of the mosquito and is passed on in the saliva of an infected insect each time it takes a new blood meal. The parasites are then carried by the blood into the victim's liver where they invade the cells and multiply. After nine to sixteen days they return to the blood and penetrate the red cells where they multiply again, progressively breaking down the red cells. This induces bouts of fever and anaemia in the infected individual. In the case of cerebral malaria the infected red cells obstruct the blood vessels in the brain. Other vital organs can also be damaged often leading to the death of the patient.

**D**

Malaria is diagnosed by the clinical symptoms and microscopic examination of the blood. It can normally be cured by anti-malarial drugs. The symptoms - fever, shivering, pain in the joints and headache - quickly disappear once the parasite is killed. In certain regions, however, the parasites have developed resistance to certain anti-malarial drugs, particularly chloroquine. Patients in these areas require treatment with other more expensive drugs. In endemic regions where transmission rates are high, people are continually infected so that they gradually develop immunity to the disease. Until they have acquired such immunity, children remain highly vulnerable. Pregnant women are also highly susceptible since the natural defence mechanisms are reduced during pregnancy.

**E**

Malaria has been known since time immemorial but it was centuries before the true causes were understood. Surprisingly in view of this some ancient treatments were remarkably effective. An infusion of qinghao containing artemisinin has been used for at least the last 2000 years in China and the antifebrile properties of the bitter bark of Cinchona Ledgeriana were known in Peru before the 15th century. Quinine, the active ingredient of this potion, was first isolated in 1820 by the pharmacists. Although people were unaware of the origin of malaria and the mode of transmission, protective measures against the mosquito have been used for many hundreds of years. The inhabitants of swampy regions in Egypt were recorded as sleeping in tower-like structures out of the reach of mosquitoes, whereas others slept under nets as early as 450 B.C.

**F**

Malaria has social consequences and is a heavy burden on economic development. It is estimated that a single bout of malaria costs a sum equivalent to over 10 working days in Africa. The cost of treatment is between \$US0.08 and \$US5.30 according to the type of drugs prescribed as determined by local drug resistance. In 1987 the total cost of malaria - health care, treatment, lost production, etc. - was estimated to be \$US800 million for tropical Africa and this figure is currently estimated to be more than \$US1800 million.

**G**

The significance of malaria as a health problem is increasing in many parts of the world. Epidemics are even occurring around traditionally endemic zones in areas where transmission had been eliminated. These outbreaks are generally associated with deteriorating social and economic conditions and the main victims are underprivileged rural populations. Economic and political pressures compel entire populations to leave malaria free areas and move into endemic zones. People who are non-immune are at high risk of severe disease. Unfortunately, these population movements and the intensive urbanisation are not always accompanied by adequate development of sanitation and health care. In many areas conflict, economic crises and administrative disorganization can result in the disruption of health services. The absence of adequate health services frequently results in recourse to self-administration of drugs often with incomplete treatment. This is a major factor in the increase in resistance of the parasites to previously effective drugs.

H

The hope of global eradication of malaria was finally abandoned in 1969 when it was recognised that this was unlikely ever to be achieved. Ongoing control programs remain essential in endemic areas. In all situations control programs should be based on half a dozen objectives: provision of early diagnosis, prompt treatment to all people at risk, selective application of sustainable preventive measures, vector control adapted to the local situations, the development of reliable information on infection risk and assessment of living conditions of concerned populations.

Malaria is a complex disease but it is a curable and preventable one.

### Questions 27 - 33

The reading passage on Malaria has 8 paragraphs (A – H). From the list of headings below choose the most suitable headings for paragraphs B – H. NB There are more headings than paragraphs, so you will not use them all.

- I. Old Remedies
- II. Fatality Rates
- III. Shifting Demographics Cause Further Problems
- IV. The Current Situation
- V. The Bug and its Carriers
- VI. Total Elimination of Malaria
- VII. Tackling Malaria Today
- VIII. Transmission to Humans and Effects
- IX. Local African Medicine
- X. Malaria's Effect on the Community
- XI. Identification

<b>Example</b>	<b>Answer</b>
Paragraph A	iv

27. Paragraph B
28. Paragraph C
29. Paragraph D
30. Paragraph E
31. Paragraph F
32. Paragraph G
33. Paragraph H

### Questions 34 - 36

Do the following statements agree with the views of the writer of Reading Passage 3 Malaria?

- |                  |  |
|------------------|--|
| <b>YES</b>       | if the statement agrees with the writer                      |
| <b>NO</b>        | if the statement doesn't agree with the writer               |
| <b>NOT GIVEN</b> | if it is impossible to say what the writer thinks about this |
34. Ancient Peruvian doctors were famous for their malarial treatment.
  35. Children are always under great threat from malaria.
  36. Poorer people are usually more at risk from malaria.

### Questions 37 - 40

Complete the following statements (Questions 37 - 40) with the best ending from the box below (A - H) according to the information in the reading passage Malaria. There are more sentence endings (A - H) than questions so you will not need to use them all.

37. Anopheline mosquitoes...
38. Parasites located in victims' livers...
39. Unfinished courses of anti-malarial drugs...
40. Control programs to protect people from malaria...
  - A. ...have finally been eradicated.
  - B. ...are not always affected by insecticides.
  - C. ...are the results of incompetent doctors.
  - D. ...are always female.
  - E. ...have been taken for hundreds of years.
  - F. ...should be based on seven clear goals.
  - G. ...have resulted in parasitic resistance to treatment.
  - H. ...are later found again in the bloodstream.

Help Now Academic Reading 9  
READING PASSAGE 1

Questions 1 - 14

### **PHRENOLOGY – INTERPRETING THE MIND**

Phrenology is the doctrine that proposes that psychological traits of personality, intellect, temperament, and character are ascertainable from analysis of the protrusions and depressions in the skull. It was an idea created by Franz Joseph Gall in 1796. Gall referred to his new idea in English as craniology. It was only later that Johanne Spurzheim, one of Gall's students, labelled the idea phrenology after Gall's death. Gall's idea was spurred when he noticed that university classmates who could memorize great amounts of information with relative ease seemed to have prominent eyes and large foreheads. He speculated that other internal qualities, besides memory, might be indicated by an external feature also. Gall theorised that traits were located in particular regions of the brain. Enlargements or depressions in the brain in particular areas meant a greater than normal or less than normal quantity of the given trait. It was assumed that the external contour of the skull accurately reflected the external contour of the brain where traits were localized.

Carl Cooter, another advocate of phrenology asserted that there were five major parts to phrenology theory. The first was simply that the brain was the organ of the mind. The second was that the brain was not a homogeneous unity, but a compilation of mental organs with specific functions. The third was that the organs were topographically localised. The fourth was that the relative size of any one of the organs could be taken as a measure of that organ's power over the person's behaviour. The fifth and final part of Cooter's theory was that external craniological features could be used to diagnose the internal state of the mental faculties. All of these parts were based on observations Cooter made.

Sebastian Leibl, a student of Cooter's, theorized that there could be anywhere from 27 to 38 regions on the skull indicative of the organs of the brain, each of which stood for a different personality characteristic. Leibl further theorised that the different regions of the brain would grow or shrink with usage, just as muscles will grow larger when exercised. If a certain part of the brain grew from increased use, the skull covering that part of the brain would bulge out to make room for the expanded brain tissue. With these assumptions, the bumps on one's skull could be felt and the abilities and personality traits of a person could be assessed.

Spurzheim put a more metaphysical and philosophical spin on Gall's concept when he named it phrenology, meaning "science of the mind". To Spurzheim phrenology was the science that could tell people what they are and why exactly they are who they are. Spurzheim wrote that the premise of phrenology was to use the methods to identify individuals who stood out at both poles of society: those with a propensity for making important social contributions and those with a greater than normal tendency for evil. The former were to be encouraged, nurtured, and developed in order to maximize their potential for good. The latter needed to be curbed and segregated to protect society from their predisposition to be harmful to others.

Phrenology has met up with a good deal of criticism since it was proposed, but over time it has also been credited for certain things. John Fancher, a critic of phrenology, states that it was a curious mixture, combining some keen observations and insights with an inappropriate scientific procedure. Most criticism is aimed at the poor methods used by phrenologists and the tangent from standard scientific procedure in investigating.

Pierre Flourens was also appalled by the shoddy methods of phrenologists and was determined to study the functions of the brain strictly by experiment. The specific technique that Flourens used was ablation, the surgical removal of certain small parts of the brain. Flourens was a very skilled surgeon and used ablation to cleanly excise certain slices from the brain. He ablated precisely determined portions of bird, rabbit, and dog brains. Flourens then observed the behavior of his subject. Since, for obvious ethical reasons, he was only able to use animals, he could not test uniquely human faculties. He never tested or measured any behaviour until he



nursed his subjects back to health after their operations. Flourens's subjects did show a lowering of all functions but not just one function as Gall's theory would have predicted. Gall asserted that he wiped out many organs all at once when he ablated part of the brain. This explained the general lowering of all functions in many of his subjects. Despite attacks from Flourens and others, phrenology held its appeal to scientists in Europe who would bring the idea across to America where it would flourish.

### Questions 1 – 8

Answer questions 1 - 8 below by writing the initials of the phrenology scientist to which the questions refer in boxes 1- 8 on your answer sheet. NB In one question you must write the initials of TWO phrenology scientists.

1. Which phrenology scientist did not use the term phrenology?
2. Which phrenology scientist theorised that you could identify people's morality using phrenology?
3. Which phrenology scientist theorised that the size of certain parts of human brains would increase if they were used a lot?
4. Which TWO phrenology scientists did not agree with the way phrenologists came to their conclusions?
5. Which phrenology scientist theorised that the size of a certain part of the brain corresponds to that part of the brain's influence over a person's actions?
6. Which phrenology scientist theorised that the human brain was a collection of cerebral organs?
7. Which phrenology scientist was an expert at performing operations?
8. Which phrenology scientist proposed theories based on his observations of colleagues?

The Phrenology Scientists	
FG	Franz Joseph Gall
CC	Carl Cooter
SL	Sebastian Leibl
JS	Johanne Spurzheim
JF	John Fancher
PF	Pierre Flourens

### Questions 9 - 14

Read the passage Phrenology - Interpreting the Mind again and look at the statements below. In boxes 9 - 14 on your answer sheet write:

**TRUE** if the statement is true  
**FALSE** if the statement is false  
**NOT GIVEN** if the information is not given in the text

9. Flourens conducted brain experiments on human patients.
10. The theories of phrenology thrived in America.
11. Gall theorised that phrenology could only indicate memory ability.
12. Flourens worked with Fancher to investigate phrenology using standard scientific experiments.
13. Gall also conducted experiments on live subjects.
14. Spurzheim's theories were used by governments as a rationale to segregate certain undesirable parts of society.

### READING PASSAGE 2

## DETECTING DECEPTION

According to lay theory there exist three core basic signs for spotting liars. These are speaking quickly and excessive fluctuations in pitch of voice, the liar becoming fidgety and hesitant when questioned on detail, and failure to make eye-contact. There is nothing too perplexing about that. Yet, a good liar will be just as aware of these as the person they're lying to and thus will ensure that eye contact especially is evident. Shifty eyes can indicate that someone is feeling emotional perhaps from a lie, or perhaps just from nerves as a result of lying. Of course, this does not apply to instances where eye contact is non-existent, like during a telephone conversation. Psychologist Paul Eckman states that extensive use of

details can make lies more believable. But they can also often trip up the liar. If the details change or contradict each other, you should suspect you're being had.

There exists an intrinsic link between emotional connections and effective lying. The notion is that it is harder to lie to those whom we know well and care for. There are two reasons for this: firstly, those close to us are more aware of our mannerisms and behavioural patterns and can more readily detect our default lying techniques. The second reason is that people we don't know lack the emotional response that people we are close to have regarding lying. Robert Galatzer-Levy, MD, a psychoanalyst in private practice, reasons that, "The good liar doesn't feel bad or have a guilty conscience, so it's much more difficult to pick up on cues that they are lying." This is why it is apparently so easy for salesmen and politicians alike to lie so effortlessly.

Recently a lot of politicians have been making outrageous claims about their ability to tell when a person is lying. Many lay people apparently believe that people can make a pretty good assessment of when a person is lying or not. Research illustrates, however, that nothing could be further from the truth.

University of Maryland professor, Patricia Wallace, an expert on deception detection states, "Psychological research on deception shows that most of us are poor judges of truthfulness and this applies even to professionals such as police and customs inspectors whose jobs are supposed to include some expertise at lie detection." She then goes on to describe two of the many experiments in the psychological research literature which support this contention.

The first study was conducted in 1987 and looked at whether police officers could be trained to detect deceptive eye witness statements. They watched videotaped statements of witnesses, some of whom were truthful and others who were not. They were told to pay close attention to non-verbal cues, such as body movements and posture, gestures, and facial expressions. They were also instructed to pay attention to the tempo and pitch of voices. In the end, however, the officers did only slightly better than chance at determining whether the witnesses were being truthful. And the more confident the officer was of his or her judgment, the more likely he or she was to be wrong.

Airline customs inspectors, whose very job is to try and determine suspiciousness and lying, and lay people were used in another experiment. The inspectors and lay people in this experiment weren't given any specific training or instructions on what to look for. They were simply told to judge the truthfulness of mock inspection interviews viewed on videotape and determine whether the passenger was carrying contraband and lying about it. The "passengers" being interviewed were actually paid volunteers whose job it was to try and fool the inspectors. Neither lay people nor inspectors did much better than chance. When questioned about what types of signs they looked for to determine lying behavior, the inspectors and lay people relied largely on preconceived notions about liars in general: liars will give short answers, volunteer extra information, show poor eye contact and nervous movements and evade questions.

What nearly all deception experiments have in common to date is that they use videotape instead of live people in their design. Some might argue that it is this very difference which politicians and others are trying to emphasize. This is that people can't tell when people are lying on videotape but can when the person is there, live, in front of them. Without research teasing out these subtle differences, however, it would be a leap of logic to simply assume that something is missing in a videotaped interview. This is a seemingly baseless assumption. A person interviewed on videotape is very much live to the people doing the interviewing. It is simply a recording of a live event. While there may be differences, we simply don't know that any indeed exist. Without that knowledge, anyone who claims to know is simply speaking from ignorance or prejudice.

The conclusions from this research are obvious. Trained professionals and untrained lay people, in general, cannot tell when a person is lying. If you've known someone for years,

your chances for detecting truthfulness are likely higher, but strangers trying to guess truthfulness in other strangers will do no better than chance in their accuracy.

### Questions 15 - 20

Do the following statements reflect the views of the writer in Reading Passage 2? Write:

YES if the statement agrees with the information

NO if the statement contradicts the statement

NOT GIVEN if there is no information on this in the passage

15. Tactics that liars use to trick people frequently give them away.
16. Good liars show less emotional response to the fact that they are lying.
17. In the two experiments described in the text, the police performed better than the airline customs inspectors.
18. The preparation for both experiments described in the text were very similar.
19. Not looking people in the eye was one technique used by the airline customs inspectors to help successfully spot liars.
20. Patricia Wallace has carried out at least two deception experiments.

### Questions 21 - 24

Complete each of the following statements (Questions 21 - 24) with words taken from Reading Passage 2. Write NO MORE THAN THREE WORDS for each answer.

Write your answers in boxes 21 - 24 on your answer sheet.

21. It has been put forward that politicians use the \_\_\_\_\_ between speaking live and on television to help them fool people.
22. Liars are often \_\_\_\_\_ the things that people look for in liars.
23. Two vocal clues that policemen listened for in their experiment were \_\_\_\_\_.
24. \_\_\_\_\_ were used to try and fool the airline customs inspectors and lay people.

### Questions 25 - 27

Using NO MORE THAN THREE WORDS OR A NUMBER from Reading Passage 2, answer the following questions. Write your answers in boxes 25 - 27 on your answer sheet.

25. Apart from television, what example does the text give of conversation when people don't look each other in the eye?
26. Who have recently asserted that they can spot liars easily?
27. What is the similarity in most psychological lying research?

## READING PASSAGE 3

### The History of Paper

- A. When we think of the origins of paper, our minds might wander back over 5000 years ago to the Nile river valley in Egypt. It was there that a marsh grass called Cyperous Papyrus flourished. The Egyptians cut thin strips from the plant's stem and softened them in the muddy waters of the Nile. These strips were then layered in right angles to form a kind of mat. The mat was then pounded into a thin sheet and left in the sun to dry. The resulting sheets were ideal for writing on. Since they were also lightweight and portable they became the writing medium of choice of the Egyptians, Greeks and Romans for record keeping, spiritual texts and works of art.
- B. Paper as we know it today comes from another source, China. It wasn't until the 3rd century that the secret art of papermaking began to creep out of China, first to Vietnam and later to India. It made its true push westward in 751AD when the Tang Dynasty was at war with the Islamic world. During a battle on the banks of the Tarus River, Islamic warriors captured a Chinese caravan which happened to include several papermakers. They spirited them away to Samarkand, which soon became a great centre for paper production. Finally, when the Moors from North Africa invaded Spain and Portugal they brought the technology with them and so it was that papermaking entered Europe in the 12th century.
- C. In Europe, the use of papyrus had dropped out in the 9th century. The preferred medium for the artists and literati of the time was the smooth and lustrous parchment. However, parchment - made from animal skin - was extremely expensive. The notion of paper being used as a practical everyday item did not occur until the 15th Century when Johann Gutenberg perfected

movable type and sparked off a revolution in mass communication. The birth of the modern paper and printing industry is commonly marked from this time.

- D. Printing technology rapidly developed and created an ever increasing demand for paper. Early European paper was made from recycled cotton and linen - and a huge trade quickly developed around the trading of old rags. It is said that the black plague entered England from Europe on these old rags. Others experimented with fibres such as straw, cabbage, wasp nests and finally wood. This resulted in inexpensive - and replaceable - materials for paper making. Today, the long soft fibres of softwoods such as spruce have become the most suitable source of pulp for mass production.
- E. The demand for paper also created the need for greater efficiency in production. In the late 18th century the labours of Nicholas Luis Robert resulted in the creation of a machine that could produce a seamless length of paper on an endless wire mesh with squeeze rollers at one end. Perfected and marketed by the Fourdrinier brothers, the new machine made papers that soon replaced traditional single sheets made by hand. In Europe and America, the mass-production of paper became a thriving industry supplying huge volumes of paper for a huge variety of purposes.
- F. Papermaking in essence is a simple process. Whether using recycled materials or fresh organic matter, the process starts as the material is shredded into small strips and soaked overnight to loosen the fibres. Next, the fibres are boiled for 2 to 6 hours, being turned every so often. When finished, the fibres are washed with fresh water to remove impurities and then small particles or specks are removed by hand. The fibres are beaten in a blender creating a creamy pulp. At this stage, dyes can be added to create coloured papers. The pulp is then poured into a large tub and the fibres are suspended in the water. Framed screens are lowered into the water and then lifted to the surface catching the fibres onto the screen. The screens are then dried, pressed and smoothed.
- G. In the west, as industrial paper production boomed, the art of hand paper-making has been driven nearly to extinction - being practiced only by a few fine artists and crafts people. However, in small areas throughout Asia, the tradition has lived on through regular and rice paper made by hand. Incidentally, the traditional Asian paper which is often referred to as "rice paper" is not made from rice fibres at all. More commonly it is made from the versatile mulberry tree - varieties of which are also used for feeding silkworms and in medicine. In contrast to the cold precision and standardisation which industrial production demands, the soft, subtle textures and natural feeling of handmade paper is said to echo the warm heart of the papermaker who makes each sheet with devotion.
- H. The new Millennium will be dominated by the tremendous progress that has been made in computer science, thus triggering a complete change in our commercial and private communication and information behaviour. Does this mean that the paper era will come to an end? The answer is most definitely "No". Clearly there will be a huge amount of data being generated electronically, but the issue is how to preserve it. The difficulties of data storage over a long period of time are well known (for example, the durability of disks; frequent changes of hardware and software, electronic breakdowns etc.). Once again, paper offers the most convenient and durable storage option.

### **Questions 28 - 34**

The reading passage on The History of Paper has 8 paragraphs A – H. From the list of headings below choose the most suitable headings for paragraphs B – H. NB There are more headings than paragraphs, so you will not use them all.

Example                      Paragraph A                      Answer                      iv

- |       |                                    |
|-------|------------------------------------|
| i.    | Arabian Expertise                  |
| ii.   | Traditional Paper Producers        |
| iii.  | Superstition                       |
| iv.   | The Origins of Paper               |
| v.    | The Development of Mass Production |
| vi.   | The Journey to the West            |
| vii.  | The Prospects for Paper            |
| viii. | The Age of Experimentation         |
| ix.   | The Father of Modern Paper         |
| x.    | The Modern Process                 |
| xi.   | A Change of Material               |

- 28. Paragraph B
- 29. Paragraph C
- 30. Paragraph D
- 31. Paragraph E
- 32. Paragraph F
- 33. Paragraph G
- 34. Paragraph H

**Questions 35 - 38**

Look at the following 8 statements A - H. According to Reading Passage 3, which FOUR statements are TRUE? The other four statements are either false or the information is not given in the passage. Choose from the appropriate letters, A - H, and write them on your answer sheet for questions 35 - 38. The answers may be written in any order.

- A. Today's style of paper originated in Egypt.
- B. Papyrus style paper was employed up to the 18th century.
- C. There is a story that disease was spread due to the great demand for paper.
- D. The author cites reasons why computer technology is not dependable.
- E. Rice Paper has been used in medicine.
- F. Paper was not used extensively until movable type was commonly used.
- G. Robert's invention led to the redundancy of the hand made paper industry.
- H. Today paper is no longer hand made.

**Questions 39 and 40**

Using the information in the passage, complete the flow chart below. Use NO MORE THAN THREE WORDS from the passage for each answer.

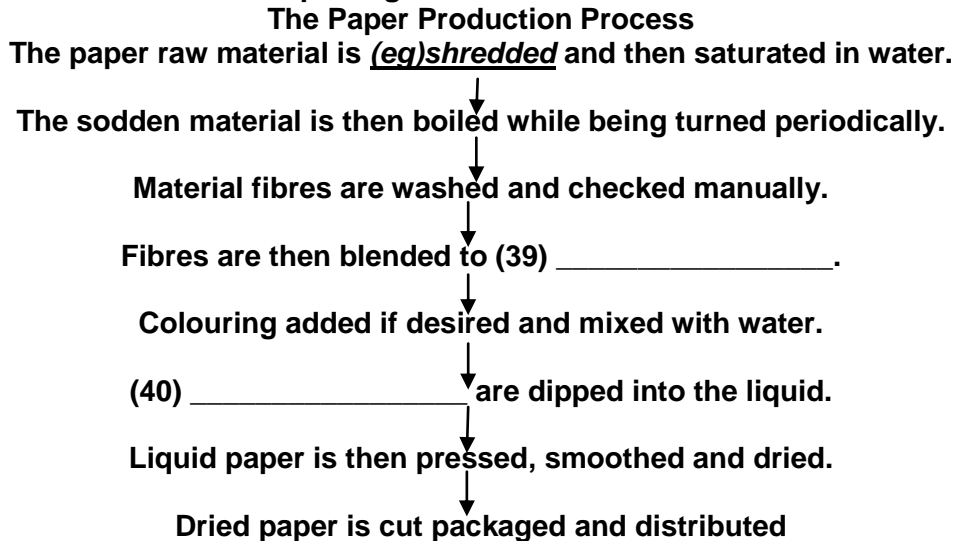

## Hydrogen Cars

**A**

Record gas prices are making road trips more expensive than ever. But what if, instead of gas, your car ran on the most abundant element in our universe? Many experts think hydrogen will replace petrol, diesel and natural gas as the main fuel for cars, buses and trucks over the next few decades. Already car manufacturers around the world have invested billions of dollars in research and development.

**B**

The advantages of hydrogen are enormous: no more smog-forming exhaust gases, no more carbon dioxide emissions that contribute to global warming, no more worries about diminishing oil supplies and rising prices. But some tricky questions need to be answered before mass-produced hydrogen cars start appearing on the streets. Where will the hydrogen come from? How will motorists fill up? How will cars store the fuel? And there's also the question of how best to tap the energy in the fuel for good, on-road performance.

**C**

Two kinds of engines can use hydrogen as a fuel; those that have an internal combustion engine converted to use it and those that are made up of a stack of fuel cells. Internal combustion engines have powered cars since they first began to replace horse-drawn carriages more than 100 years ago. These engines can be converted to run on a variety of fuels, including hydrogen. However, most car makers think that fuel cells powering an electric motor offer a better alternative. Unlike heavy batteries that need frequent recharging, fuel cells make electricity as they go. Recent developments in technology too have greatly increased the amount of power that a stack of cells can provide. This has opened up the prospect of efficient, non-polluting electric cars.

**D**

Fuel cell technology sounds simple. The hydrogen fuel reacts with oxygen from the air to produce water and electricity, the reverse of the familiar electrolysis process that releases oxygen and hydrogen from water. In reality of course it's a bit more complicated. The big advantage of a fuel cell engine over an internal combustion engine running on hydrogen is its greater efficiency. The same amount of hydrogen will take a fuel cell car at least twice as far as one with a converted internal combustion engine.

**E**

Hydrogen has many advantages as a fuel for vehicles, but a big disadvantage is that it is difficult to store. This is because at normal temperatures hydrogen is a gas. The obvious solutions are to strongly compress the hydrogen, or liquefy it. However, tanks designed to hold hydrogen at extremely high pressures, or at temperatures approaching absolute zero, are heavy and expensive. So, high cost and the large amount of energy needed to liquefy the fuel are likely to be the main problems with refuelling with liquid hydrogen. Filling up with compressed hydrogen gas will probably prove more practical, even though it may reduce the distance between fills. Cars could store the hydrogen in high pressure tanks similar to those used for compressed natural gas or specially treated carbon may also hold large amounts.

**F**

Although there's no risk that we'll ever run out of hydrogen, on Earth it exists naturally only in chemical compounds, not as hydrogen gas. A relatively simple principal technology, steam reforming, can produce hydrogen gas for cars at central plants or filling stations. Alternatively fuel tanks could be filled with petrol or methanol, with the cars using on-board reformers to generate hydrogen for their fuel cells. This shows promise as a transitional measure while research proceeds on the problems of storing hydrogen. Water is the only potentially pollution-free source of hydrogen. Researchers are looking at new ways of producing hydrogen from water such as using algae, bacteria or photovoltaic cells to absorb sunlight and split water into hydrogen and oxygen. But the technology most likely to be adopted on a large scale is electrolysis, which uses an electric current to split water into oxygen and hydrogen.

**G**

'Remember the Hindenburg' – that's a phrase often heard when hydrogen is discussed. This German passenger airship, kept aloft by hydrogen, crashed in flames as it came in to land at Lakehurst, New Jersey, USA in May 1937. Thirty-five people died. Nowadays helium, which can't burn, is the gas of choice for lighter-than-air craft. Hydrogen is highly flammable, but recent research has indicated that the airship's fabric, not hydrogen, was the culprit in the Hindenburg disaster. Properly handled, there's no reason to think hydrogen is any more dangerous as a fuel than petrol, the explosive liquid now carried safely in the tanks of untold millions of motor vehicles.

H

Recent technological advances, particularly in fuel cell design, have made hydrogen-powered cars a practical proposition, and car makers expect to start mass-producing them within the next decade or so. Their power and acceleration should match those of today's conventionally-powered vehicles, but they may have to be refuelled more often. The best ways to produce, distribute and store the hydrogen still have to be sorted out. In the short term fossil fuels may remain in demand as a hydrogen source. However, the idea that in the not too distant future most of us will be driving non-polluting cars fuelled by hydrogen from a clean, renewable source is no longer a flight of fantasy.

### Questions 1 - 7

Reading Passage 1 has 8 paragraphs (A – H). From the list of headings below choose the most suitable headings for paragraphs B – H. Write the appropriate number (i – xi) in boxes 1 – 7 on your answer sheet. NB There are more headings than paragraphs, so you will not use them all.

*Example* Paragraph A *Answer* iv

### Headings

- |       |  |  |
|-------|--|--|
| i.    | Hydrogen Storage                               |  |
| ii.   | Traditional Production Methods                 |  |
| iii.  | The Possible Danger of Combustible Hydrogen    |  |
| iv.   | A Plentiful Alternative                        |  |
| v.    | Looking Forward                                |  |
| vi.   | Good Idea but...                               |  |
| vii.  | Today's Hydrogen Production                    |  |
| viii. | How the Process Works                          |  |
| ix.   | Hydrogen Sources and Production                |  |
| x.    | The Workings of the Internal Combustion Engine |  |
| xi.   | The Engine Dilemma                             |  |
1. Paragraph B
  2. Paragraph C
  3. Paragraph D
  4. Paragraph E
  5. Paragraph F
  6. Paragraph G
  7. Paragraph H

### Questions 8 - 12

Complete each of the following statements (Questions 8 - 12) with words taken from Reading Passage 1. Write NO MORE THAN THREE WORDS for each answer.

8. There is no reason that we'll run out of hydrogen as it's the \_\_\_\_\_ that exists.
9. \_\_\_\_\_ have been devoted by companies to producing hydrogen cars.
10. \_\_\_\_\_ could use traditional fuels to produce the hydrogen needed to power hydrogen cars.
11. Investigations have proved that \_\_\_\_\_ was the cause of the Hindenburg disaster.
12. Hydrogen cars have the potential to offer the \_\_\_\_\_ that we associate with today's fossil fuel powered vehicles.

### Questions 13 and 14 Choose the appropriate letters A – D that best answer the question

13. Which of the following is NOT a potential problem with the introduction of hydrogen cars?
  - A. The frequency of refueling stops.
  - B. The creation of by-products of the electricity production process.
  - C. The volatility of hydrogen.
  - D. Keeping hydrogen in cars.

14. Which of the following hydrogen production methods for hydrogen powered cars is viewed in the article as a temporary measure?
- A system producing hydrogen from fossil fuels.
  - A method producing hydrogen from water vapor.
  - A process using microscopic organisms to produce hydrogen.
  - An electrolysis basis hydrogen production system.

READING PASSAGE 2

Questions 15 - 27

## CLONING

### Paragraph A

The ethics of human cloning has become a great issue over the past few years. The advocates for both sides of the issue have many reasons to clone or not to clone. A recent poll has shown the differences in opinions with half as many women as men approving of the process. Many people find it strange to see such a clear difference between men and women with twenty-six percent of men favouring cloning.

### Paragraph B

So, what is cloning? It has been defined as “the production of genetically identical organisms via somatic cell nuclear transfer”. You take an egg and remove its nucleus, which contains the DNA/genes. Then you take the DNA from an adult cell and insert it into the egg, either by fusing the adult cell with the enucleated egg, or by a sophisticated nuclear transfer. You then stimulate the reconstructed egg electrically or chemically and try to make it start to divide and become an embryo. You then use the same process to implant the egg into a surrogate mother that you would use with artificial insemination. What cloning does is that it copies the DNA/genes of the person and creates a genetic duplicate. The person will not be a Xerox copy. He or she will grow up in a different environment than the clone, with different experiences and different opportunities. Genetics does not wholly define a person and the personality.

### Paragraph C

In February 1997, when embryologist Ian Wilmut and his colleagues at Roslin Institute in Scotland were able to clone a lamb named Dolly, the world was introduced to a new possibility and will never be the same again. Before this, cloning was thought to be impossible, but now there is living proof that the technology and knowledge to clone animals exist. Questions began to arise within governments and scientific organisations and they began to respond. Are humans next? Is it possible to use this procedure to clone humans also? Would anyone actually try? What can we learn if we clone humans? How will this affect the world? These are only a few of the questions that have surfaced and need answering. A whole new concept in ethics was created when the birth of Dolly was announced.

### Paragraph D

When the cells used for cloning are stem cells, we are talking about cells that are pluripotential. This means that they have the capacity to develop into any of the numerous differentiated cell types that make up the body. Early embryonic cells are pluripotent and a limited number of stem cells are also found in adults, in bone marrow for instance. There is an important distinction to be made between therapeutic cloning and reproductive cloning. Reproductive cloning would be exactly like Dolly; it would involve the creation of a cloned embryo which would then be implanted into a womb to develop to term and the birth of a clone. On the other hand, therapeutic cloning involves the use of pluripotent cells to repair damaged tissue, such as found after strokes, Parkinson’s disease and spinal cord injuries.

### Paragraph E

There is evidence for the effectiveness of therapeutic cloning as shown by work involving the introduction of stem cells into the brain of patients suffering from brain diseases, when the cells which have been added differentiate to form nerve cells which can in turn then lead to recovery of the lost function. In the US, foetal human cells have been similarly used though recent reports indicate that the results so far are disappointing. However, apart from the ethical problems associated with the use of foetal cells in this way, there are simply not enough cells available for it to be an effective treatment, since it needs the cells from three foetuses to treat one patient.

### Paragraph F



After Dolly, governments began to take control and make laws before anything drastic could ever happen. Several ethics committees were asked to decide whether scientists should be allowed to try to clone humans. In the United States, the Bioethics Advisory Commission recommended a five-year moratorium on cloning a child through somatic cell nuclear transfer. In the United Kingdom, the Human Fertilisation and Embryology Authority and the Human Genetics Advisory Commission have approved human cloning for therapeutic purposes, but not to clone children. Many organisations have come out and stated their opinions also. Amongst all this ethical defining, many people are being ignored by the governments. People are speaking out about what they want done.

**Paragraph G**

Historically, we find that many a great medical breakthrough, now rightly seen as a blessing, was in its own time condemned by bio-conservative moralists. Such was the case with anaesthesia during surgery and childbirth. People argued that it was unnatural and that it would weaken our moral fibre. Such was also the case with heart transplantations and with in vitro fertilization. It was said children created by IVF would be dehumanised and would suffer grave psychological harm. Today, of course, anaesthesia is taken for granted; heart transplantation is seen as one of medicine's glories and the public approval rate of IVF is up from 15% in the early seventies to over 70% today.

**Questions 15 - 20**

Reading Passage 2 has 7 paragraphs (A - G). Which paragraphs offers information on the following ideas? One paragraph is used more than once and two are not used at all.

- 15. Different types of cloning.
- 16. Protective legislation.
- 17. Similar situations
- 18. A survey on attitudes towards cloning.
- 19. Scientific reasons why cloning is currently not viable for medical cures.
- 20. Illness examples that cloning could help treat.

**Questions 21 - 24**

Choose the appropriate letters A – D and write them in boxes 21 – 24 on your answer sheet.

21. Which bar chart most accurately describes attitudes indicated in the text towards cloning by men and women?

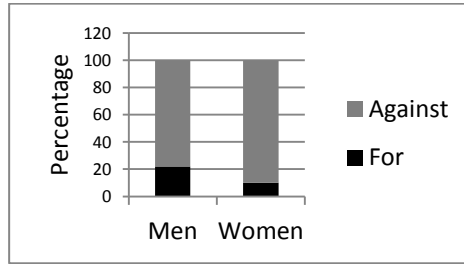
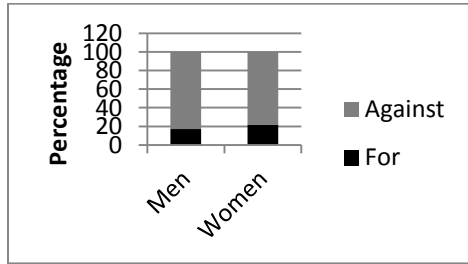

**A**

**B**

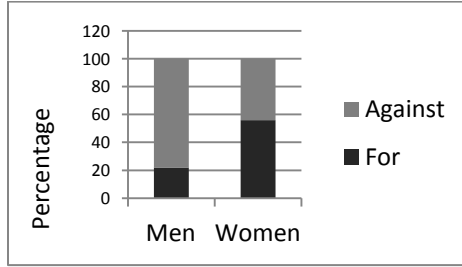
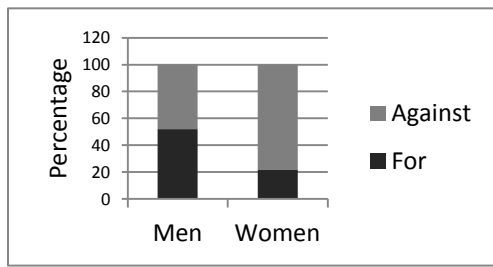

**C**

**D**

22. Which of the following is a feature of cloning used for possible medical treatment?

- A. A genetic duplicate is born through use of a surrogate mother.
- B. The creation and implantation of an embryo.
- C. Implantation of differentiated pluripotent cells.
- D. Genetic mutation of pluripotent cells.

23. Which of the following is NOT a feature of cloning?
- Reproduction of a genetic copy of the subject cloned.
  - Reproduction of exact personality characteristics of the subject cloned.
  - Reproduction of the pluripotential stem cells of the subject cloned.
  - Reproduction of the DNA of the subject cloned.
24. Which of the following is NOT an example from the text of previous medical technologies that were initially mistrusted by people?
- Test tube babies.
  - Anaesthesia.
  - Antiseptics.
  - Heart replacements.

### Questions 25 - 27

Using NO MORE THAN THREE WORDS from Reading Passage 2, answer the following questions.

- In what part of an egg is found the DNA used for cloning?
- In what country has medical treatment through cloning been shown to be of limited value?
- According to the text, what body wants to wait before cloning a human?

### READING PASSAGE 3      Questions 28 - 40

## What is Intelligence?

Intelligence can be defined in many different ways since there are a variety of individual differences. Intelligence to a lot of people is the ability to reason and respond quickly yet accurately in all aspects of life, such as physically, emotionally, and mentally. Anyone can define intelligence because it is an open-ended word that has much room for interpretation but there are some theories which have more general acceptance than others.

Jean Piaget, a Swiss child psychologist, is well known for his four stages of mental growth theory. The first stage is the sensorimotor stage, from birth to age 2, the child is concerned with gaining motor control and getting familiar with physical objects. Then from age two to seven, the child develops verbal skills. This is called the preoperational stage. In the concrete operational stage the child deals with abstract thinking from age seven to twelve. The final stage, called the formal operational stage, ends at age fifteen and this is when the child learns to reason logically and systematically. Piaget's theory provides a basis for human intelligence by categorising the major stages in child development and how they contribute to intelligence. Each of these invariant stages has major cognitive skills that must be learned. Knowledge is not merely transmitted verbally but must be constructed and reconstructed by the learner. Thus this development involves a few basic steps. The first fundamental process of intellectual growth is the ability to assimilate the new events learned into the pre-existing cognitive structures. The second fundamental process is the capability to change those structures to accommodate the new information and the last process is to find equilibrium between the first two processes.

Howard Gardner, a psychologist at Harvard University, has formulated an even more intriguing theory. He arranged human intelligence into seven sections. First of all Gardner characterises the logistical-mathematical intelligence as people who think logically and are able to transfer abstract concepts to reality. These people enjoy solving puzzles and can be good inventors because they can visualize an invention even before making a prototype. They normally do better in school, which is for the most part due to the fact that schools are designed for logical-mathematical type of thinkers. The linguistic type, as you might guess, is the natural born writer and poet. They usually have excellent storytelling skills, spelling skills, and love to play with words. They tend to be bookworms and can easily learn more than one language. This type of intelligence seems to be located in the Broca's Area, since damage to that portion of the brain will cause a person to lose the ability to express themselves in clear grammatical sentences, though that person's understanding of vocabulary and syntax remains intact. Next Gardner traced musical intelligence to certain areas of the brain. Impaired or autistic children who are unable to talk or interact with others have often exemplified exceptional musical talent. People of this type of intelligence show great aptitude for music, have excellent pitch, and a good sense of rhythm. They concentrate better with music playing in the background. A particular concerto by Mozart has shown positive changes in the brains of listeners. Thus, musical intelligence can be a form or

a means of learning. Another form of intelligence is the interpersonal intelligence. This category is for people who are very well aware of their environment. They tend to be sensitive to people around them, have an excellent idea of how people behave, and are especially sociable. Politicians, leaders, counselors, mediators, and clergy are excellent examples of people with this type of intelligence. Damage to the frontal lobe has shown damage to this type of person's personality and his or her ability to interact with others. Intrapersonal intelligence is almost the opposite of interpersonal intelligence. This kind of intelligence deals with how well you know yourself. People who possess a higher degree of this type of intelligence have a high self-esteem, self-enhancement, and a strong sense of character. They are usually deep thinkers, self-teachers, skilled in music or art, and have an inner discipline. This sort of intelligence is hard to measure since it is often difficult to recognize externally. Spatial intelligence is the ability to perceive and interpret images or pictures in three-dimensional space. The right hemisphere of the brain has been proven to control this form of intelligence and scientists are certain that spatial intelligence is clearly an independent portion of this intellect. A person of this intellect enjoys making maps and charts. Lastly, Gardner classifies people who are athletically inclined into the body-kinesthetic intelligence. They perform the best in atmospheres of action, touching, physical contact and working with their hands. Dancers and athletes are good examples of this form of intellect. Critics are a little sceptical that Gardner considers this a form of intellect since it is only a physical component of intelligence, but nonetheless, the brain does use both hemispheres to control movement.

Gardner believes that everyone has a mixture of all the categories varying at different levels. We can see a couple of intelligence types that stand out in people we know and including ourselves. For example a math major's logical-mathematical intelligence would be more predominant than his linguistic intelligence.

#### Questions 28 - 34

Gardner's Intelligence Types and some descriptions of different types of people displaying different aspects of Gardner's Intelligence types are listed below in two boxes.

Match each description with the appropriate intelligence type.

#### Gardner's Intelligence Types

- A. Logistical-mathematical type
- B. Linguistic type
- C. Musical type
- D. Interpersonal type
- E. Intrapersonal type
- F. Spatial type
- G. Body-kinesthetic type

- 28. People with this type of intelligence are often good at developing new products for a company.
- 29. People with this type of intelligence are often good novelists.
- 30. People with this type of intelligence often mix well with other people.
- 31. People with this type of intelligence are often very self-confident.
- 32. Young people with mental handicaps frequently display this type of intelligence.
- 33. People with this type of intelligence often learn by imagining things as pictures.
- 34. People with this type of intelligence are often good physiotherapists.

#### Questions 35 - 40

Read the passage *What is Intelligence?* again and look at the statements below. Write:

- TRUE *if the statement is true*  
 FALSE *if the statement is false*  
 NOT GIVEN *if the information is not given in the text*

- 35. There are no theories of intelligence which have universal recognition around the world.
- 36. Part of Piaget's development theory includes children learning how to walk.
- 37. Piaget theorised that psychological development is finished before adulthood.
- 38. Piaget's and Gardner's theories are not mutually exclusive.
- 39. People usually have a blend of Gardner's intelligence types.
- 40. Someone can identify in themselves the kinds of Gardner's intelligence types that they display.

IELTS Masterclass Reading (compiled 1)

## **The Invisible Thread**

- A. It lifts hearts and lengthens lives. It has been hailed as the ultimate good by philosophers and promoted by major religions. The wondrous good in question is friendship. Aristotle's highest goal for men and the third plank of the French revolution - liberty, equality, fraternity — friendship is as aid as humanity and as important as love or justice. But while bookshop shelves groan with self-help books on finding the perfect partner and philosophical texts on the nature of freedom, friendship barely gets a mention among academics or policy-makers.
- B. Friendship is the invisible thread running through society, yet its significance in our lives is, if anything, increasing. While the claim that 'friends are the new family' is an overstatement, it is certainly the case that friendships figure prominently in both the lives people actually lead and the ones to which they aspire. Television programmes such as Friends portray a world in which close friendships define the contours of the participants' lives: parents and children are allowed, at best, walk-on parts.
- C. One of the reasons why thinkers struggle to recognize this trend may be one of definition. After all, I am a friend to someone I have known and loved for twenty-five years, but I am also a "Friend of The Earth". Friendship is a slippery category. This, however, is where philosophers are supposed to help. Aristotle divided friendships into three types: friendships for usefulness, friendships for pleasure, and friendships of virtue.
- D. The first kind of friend is the one who will get you a job or membership of an exclusive club; the second makes you laugh. But in both cases the point of the friendship is that they provide something of separate value to you. True friendship, the third kind, is valued for itself. There are few numerical limits on the first two kinds — I can have a vast business network and hundreds of agreeable acquaintances — but true friendship is, by definition, a limited field: if someone has many friends, they have none.
- E. Virtuous friendship is long-term and committed and brings great psychological benefits, and there is plentiful research evidence showing that having at least one close friend is associated with a range of health benefits, from recovery times from cardiac illness to reduced incidence of mental health problems.
- F. However, friendship is not always an unalloyed good. Its benefits are unevenly spread and its impact on traditional liberal values, such as equality, diversity and mobility, is mixed. The first problem is that men are worse at friendship than women. It is now widely acknowledged that women do more of the "social" work than men and have better-developed friendship skills, which leaves men at a disadvantage.
- G. Secondly, friendship has political downsides for governments committed to social inclusion: it is, by definition, exclusive. People from a particular social class or educational background are highly likely to form friendships, or romantic relationships, with people from the same background. Given that friends help each other, the danger is that the friendships of the affluent and successful hoard social advantage to the detriment of social mobility.
- H. Friendship is seen — with some justification — as a private matter, but the strong links between friendship and other social goods — including better health, more effective careers, and higher life satisfaction — should be enough to merit greater attention from decision makers. So what are the political implications of these observations? Perhaps the best politicians can aim for is not to make things worse for friendship. But political institutions can improve or worsen the conditions in which friendships are formed.
- I. First of all, the issue of time needs to be considered. Friendship requires time to flourish:

Aristotle reckoned one and a half bushels of salt needed to be consumed together before a friendship became solid. At the present time, many people regard non-working hours as family time, but little allowance is made for the time needed to build friendships. Ironically, for politicians to discourage people from working long hours could be counter-productive, since a third of us make most of our friends through work. What the decision-makers could do, however, is discourage the drive for commercial gain that squeezes conviviality out of the workplace.

- J. There is also a case for encouraging spaces in which people from different backgrounds meet and interact in order to increase the chances of cross-class friendships. Given the increase in geographical inequality, with rich people increasingly living in neighbourhoods of rich people, only hospital wards and places of religious worship are sites of genuine social mixing.
- K. Friendship is a virtue with some of the appearances of a social vice. It can promote or demote social mobility; underpin tolerance or bolster discrimination; erode or sustain hierarchies. Society could be composed of strong friendships between people of identical social backgrounds who treat everyone else with contempt, intolerance or fear. The true test of the friendliness of a community is not simply the way its citizens treat their friends, but whether they behave generously towards the broader social world. We need not only the care of friends, but the kindness of strangers.

#### Questions 1- 6

Which paragraphs A—K of the article contain the Following information?

1. the effect of gender on people's ability to make friends
2. friendship: a frequently disregarded influence for good
3. the difficulty of defining friendship
4. the distinction between a real friend and other kinds of friends
5. the similarities between people who are close friends
6. people's need for friends as well as family

#### Questions 7-13

Do the following statements agree with the views of the writer of the article? Write

YES if the statement agrees with the views of the writer

NO if the statement contradicts the views of the writer

NOT GIVEN if it is impossible to say what the writer thinks about this.

7. Friendship has become less important in people's lives.
8. It is impossible for anyone to have a large number of genuine friends.
9. Having a genuine friend improves a person's life in a variety of ways.
10. Wealthy people find it more difficult to form close friendships.
11. Politicians cannot influence people's chances of making friends.
12. Reducing the number of hours people spend at work would help people to form friendships.
13. It is difficult for people who do not live close to each other to be good friends.

## Passage 2

**Questions 14-20**

The reading passage has eight paragraphs A-H. Choose the most suitable headings for paragraphs B-H from headings i-x below.

Example: Paragraph A                      Answer iii

14. Paragraph B
15. Paragraph C
16. Paragraph D
17. Paragraph E
18. Paragraph F
19. Paragraph G
20. Paragraph H

## Headings

- i.        Measuring mobility
- ii.       Deadly venom essential
- iii.      Stung while swimming
- iv.       Recovering From the stings
- v.        How to avoid being stung
- vi.       Unexpected discoveries
- vii.      A serious lack of knowledge
- viii.     All-round vision
- ix.       Very small but highly dangerous
- x.        Spiders that kill

**ARMED AND DANGEROUS**

- A. The yacht was anchored 200 metres off the Queensland coast when Chris Slough dived into the water. That's when it got him. 'I felt a couple of little stings on my chest,' he says, 'but I thought nothing of it and carried on.' But as soon as he got back on the boat he realized he was in big trouble. 'I suddenly came over very nauseous', he says. Within minutes he was in agonizing pain, vomiting and struggling to breathe. 'It felt like my organs were popping out.'
- B. Chris had been stung by an irukandji, a vicious creature named after an aboriginal tribe whose folklore tells of a terrible illness that struck people who went swimming in the sea. Irukandjis, a species of box jellyfish, grow no bigger than a peanut, yet relative to their size are probably the most toxic creatures on earth, putting many people in hospital each year with 'irukandji syndrome'. All but invisible in the water, their transparent bodies are covered from head to tentacle tip in stinger cells that discharge at the slightest touch, harpooning your skin with venomous barbs. The sting itself is often so mild that you barely notice it until the powerful venom kicks in.
- C. When Chris arrived in hospital, he was given a massive dose of painkillers but no antivenin. Despite the severity and frequency of irukandji stings, no one has characterized its venom, or identified the properties of that of any other species of box jellyfish. In fact, almost everything about box jellyfish is a mystery. Chris was lucky not to have brushed up against chironex fleckeri, a brutish creature the size of a birthday cake with sixty sting-encrusted tentacles. Chironex has killed at least sixty-seven people in Australia since records began in 1883, more than the notorious red-back spider. It can kill a grown man in three minutes flat. Even so, no one knows what's in its venom.
- D. Rattled by bad publicity the tourist industry has been pouring money into box jellyfish research. What the biologists are finding comes as a big surprise. It turns out that box jellyfish are not jellyfish at all. In fact, it looks as though they have been ploughing a separate evolutionary furrow since the Pre-Cambrian period, 543 million years ago. What's more, the sea is teeming with unknown species. Even a cursory survey has revealed more than a dozen undescribed ones, some probably even more dangerous than chironex and the irukandji.
- E. Jamie Seymour, a tropical biologist at James Cook University in Cairns, has developed a technique for tracking chironex's movements using tiny ultrasonic transmitters stuck on with surgical superglue. True jellyfish are dim-witted ocean drifters, but, the first time Seymour

managed to tag a chironex with one of these, it immediately headed straight for the bottom, then suddenly swam off covering nearly half a kilometre in fifteen minutes. One simple fact underlies this behaviour: box jellies are voracious predators. 'You see whole chunks of fish inside them,' says Seymour. Drifting around aimlessly is not a good strategy for a fish eater, so they charge around in search of prey.

- F. Another remarkable feature of box jellyfish is their visual system. They have twenty-four eyes, arranged in clusters of six, one on each side of their cuboid body. Each cluster contains two types of eye - four simple light-sensing pits plus two sophisticated 'camera eyes'. The latter are anatomically similar to human eyes, with lenses, retinas, and corneas, and can form detailed colour images, but all this sophisticated equipment begs a question. How do box jellies deal with all the information their eyes gather when they don't have a brain? What happens, for example, when two different eyes are sending out contradictory information? No one knows. Why would a creature so apparently primitive need such sophisticated eyes, and so many of them? Some scientists have suggested that this is to do with finding optimum hunting grounds, but Seymour goes one further. He believes that box jellyfish actively seek out prey. He says he has seen them swim around obstacles and home in on individual fish.
- G. Their predatory eating habits also explain why they have such lethal toxins. It's one thing to stalk fish, but how do you catch them when all you have are flimsy, rubbery tentacles? The answer is to take them out with as much lethal force as possible. A chironex sting certainly does that – its venom can dispatch a fish in less than two minutes. It's just an evolutionary accident that the toxin works so well on us too. Seymour suspects there are more deaths than are officially recognised. He points out that chironex fleckeri was thought to be confined to northern Australian waters but has now been found in Papua New Guinea, Malaysia, Indonesia, the Philippines, Thailand, and Vietnam. The irukandjis too are probably widespread in the Indo-Pacific. 'People are getting stung and killed all over the tropics without anybody realizing the true cause,' he says.
- H. As for Chris, the painkillers worked well enough to let him lie down without it hurting. And he was lucky to have a short bout — it only took twenty hours for him to stop feeling like he was going to die.

**Questions 21-24:**

Complete sentences 8-11 with the correct ending A-G from the box below.

21. At first, box jellyfish stings may not hurt much
22. Doctors could not give Chris antivenin at the hospital
23. Box jellyfish have to be able to swim well
24. The number of human victims is probably underestimated
  - A. because they have extremely good eyesight.
  - B. because these creatures live in more places than was realized.
  - C. because they are not really a kind of jellyfish.
  - D. because they cause much less pain than the venom.
  - E. because we don't know how many kinds of box jellyfish there are.
  - F. because they need to go after the fish they eat.
  - G. because the exact nature of the venom is unknown.

**Questions 25-27:**

Answer the questions with words from the Reading Passage. Write **NO MORE THAN THREE WORDS** for each answer.

25. How long, apparently, have box jellyfish differed from true jellyfish?
26. What did Seymour fasten to the box jellyfish?
27. What do box jellyfish lack for processing visual data?

## Section 3

**The Phantom Hand**

*This illusion is extraordinarily compelling the first time you encounter it.*

1. There is a very striking illusion in which you can feel a rubber hand being touched as if it were your own. To find out for yourself, ask a friend to sit across from you at a small table. Set up a vertical partition on the table, rest your right hand behind it where you cannot see it, and place a plastic right hand in view. Ask your assistant to repeatedly tap and stroke your concealed right hand in a random sequence. Tap, tap, tap, stroke, tap, stroke, stroke. At the same time, while you watch, they must also tap and stroke the visible plastic dummy at exactly the same time in the same way. If your friend continues the procedure for about twenty or thirty seconds, something quite strange will happen: you will have an uncanny feeling that you are actually being stroked on the fake hand. The sensations you feel will seem to emerge directly from the plastic.
2. Why does this happen? Matthew Botvinick and Jonathan Cohen, at the University of Pittsburgh and Carnegie Mellon University, who reported the so-called rubber-hand illusion in 1998, have suggested that the similarity in appearance feels the brain into mistaking the false hand for your real hand. They believe this illusion is strong enough to overcome the discrepancy between the position of your real hand that you can feel and the site of the plastic hand you can see.
3. But that is not the whole story. William Hirstein and Kathleen Carrie Armel of the University of California discovered a further twist: the object your helper touches does not even need to resemble your hand. The same effect is produced if they tap and strike the table. Try the same experiment, but this time get your acquaintance to rub and tap the surface in front of you while making matching movements on your real, concealed hand. You will eventually start feeling touch sensations emerge from the wood surface.
4. This illusion is extraordinarily compelling the first time you encounter it. But how can scientists be certain that the subject really believes that they are feeling sensations through the table? Kathleen Carrie Armel again and Vilayanur S Ramachandran learned that, once the illusion has developed, if you 'threaten' the table by aiming a blow at it, the person winces and even starts sweating. This reaction was demonstrated objectively by measuring a sudden decrease in electrical skin resistance caused by perspiration. It is as if the table becomes incorporated into a person's own body image so that it is linked to emotional centres in the brain; the subject perceives a threat to the table as a threat to themselves.
5. This may all sound like a magic trick, but it does have practical applications. In fact, the experiments were inspired by work with patients who had phantom limbs. After a person loses an arm from injury, they may continue to sense its presence vividly. Often, the phantom seems to be frozen in a painfully awkward position. To overcome this, a patient was asked to imagine putting their phantom arm behind a mirror. By then putting their intact arm on the reflective side, they created the visual illusion of having restored the missing arm. If the patient now moved the intact arm, its reflection - and thus the phantom - was seen to move. Remarkably, it was felt to move as well, sometimes relieving the painful cramp.
6. Beyond a practical application, these illusions also demonstrate some important principles underlying perception. Firstly, perception is based largely on matching up sensory inputs. As you feel your hand being tapped and stroked and see the table or dummy hand being touched in the same way, your brain asks itself, 'What is the likelihood that what I see and what I feel could be identical simply by chance'? Nil. Therefore, the other person must be touching me.' Secondly, this mechanism seems to be based on automatic processes that our intellect cannot override. The brain makes



these judgments about the senses automatically; they do not involve conscious thought. Even a lifetime of experience that an inanimate object is not part of your body is abandoned in light of the perception that it is.

7. All of us go through life making certain assumptions about our existence. 'My name has always been Joe,' someone might think. 'I was born in San Diego,' and so on. All such beliefs can be called into question at one time or another for various reasons. One premise that seems to be beyond question is that you are anchored in your body. Yet given a few seconds of the right kind of stimulation, even this obvious fact is temporarily forsaken, as a table or a plastic hand seem to become part of you.

**Questions 28-31:**

The text reports the findings of three teams of researchers. Match statements 1- 4 with the correct team A, B or C.

A. Botvinick and Cohen

B. Hirstein and Armel

C. Armel and Ramachandran

28. The illusion does not depend on the 'phantom' looking like a real hand.

29. The brain can disregard spatial information.

30. If the fake hand is threatened, the subject will show signs of fear.

31. A hand-shaped object is required for the illusion.

**Questions 32-34:**

Choose the correct letters A, B, C or D in answer to these questions.

32. How do researchers explain the fact that subjects respond physically when someone threatens to hit the table in front of them?
- A. The table becomes an integral part of the image subjects have of themselves.
  - B. It is a reflex action triggered by the movement of the other person's hand.
  - C. An electrical connection is established between the subject and the table.
  - D. Over time, the subject comes to believe that the table is one of his possessions.
33. What does the phantom hand experiment show us about the nature of human perception?
- A. It is based on conscious thought processes.
  - B. It is primarily an unconscious process.
  - C. It is closely related to intellectual ability.
  - D. It relies only on sensory information.
34. Which of these statements best summarizes the wider implications of the experiments described in the text?
- A. The experiments are valuable in treating patients who have lost limbs.
  - B. The experiments cast doubt on a fundamental human assumption.
  - C. The experiments show humans to be less intelligent than was once thought.
  - D. Human beings arrive at the truth by analysing the evidence of their senses.

**Questions 35-40:**

Complete the summary below. Choose ONE WORD FROM THE TEXT AND/OR A NUMBER for each answer.

It is a recognized phenomenon that patients who have been injured and lost (35) ..... sometimes continue to have feelings, like pain or (36) ..... , in these parts of their body. In order to assist patients like this, doctors can use a (37) ..... placed vertically on a flat surface. The patient imagines that he is putting his phantom arm behind the mirror and his (38) ..... arm in front. When the patient moves the latter, the (39) ..... also moves, giving the patient the illusion that his non-existent arm is moving- In some cases, this illusory movement may succeed in (40) ..... the patient's discomfort.

IELTS Masterclass Reading (compiled 2)

## Tower of Strength

- A. Of all the stories of art influencing science, tensegrity is one of the most far-reaching. On one level, tensegrity is a system of creating architecture or sculptures involving rods in compression and wires in tension. It was invented by sculptor Kenneth Snelson at Black Mountain College, the hotbed of international modernism, in 1948. At the time, Snelson was taking part in a summer school with the engineer Buckminster Fuller, who pioneered the idea of applying geometric forms to architectural and engineering innovation.
- B. Using an abstract sculpture as a starting point, Snelson then added tension wires to the free-floating members. Fuller encouraged him and when they met up again in 1949, Snelson had perfected a concept in which stiff rods can be supported without touching by a network of wires. Although “tensegrity” (from ‘tensional integrity’) was coined by Fuller, the idea was entirely Snelson’s, and he went on to make many more tensegrity sculptures, the most famous of which is the sixty-foot high Needle Tower (1968), now at the Hirshhorn Museum and Sculpture Garden, Washington DC.
- C. Basic tensegrity structures can be made from three drinking straws, six paper clips, and nine rubber bands. When the structure is wired up, you can see that none of the rods actually touch; they’re held in equilibrium by the rubber bands. Even this simplest model has very interesting properties. Although drinking straws are weak, with a tendency to buckle, the tension bands hold them in such a way that the compressive force is always directed straight down the tube and buckling doesn’t happen. The first thing you notice if you make one is that it is immensely fiddly to assemble — pieces keep falling apart — but once the last band is secured, you can fling the object around, squash it, and it seems indestructible. The structure isn’t symmetrical in its properties. In one direction, it squashes flat and bounces back. In the other direction, it resists the pressure. If you wanted to create versatile 3D structures out of nothing much, tensegrity would take some beating.
- D. It is strange that architects and engineers didn’t discover the principle before 1948, since the benefits of structures held in tension over traditional building techniques had been known since the invention of the suspension bridge in 1796. And the great maverick biologist D’Arcy Thompson in *On Growth and Form* (1917) had extensively analyzed the principles of tension and compression both in nature and engineering. Kenneth Snelson believed that tensegrity was a pure art and that it would never be really useful architecturally. It took some time to prove him wrong, but in the 1980s, tensegrity architecture began to appear. The key protagonist was David Geiger and the first important structure was his Gymnastics Hall at the Korean Olympics in 1988.
- E. Five years later, its significance in quite a different field became apparent when scientists described the tensegrity model of cell structure, and this is where the principle is now making waves. What is it that prevents living things from collapsing to a blob of jelly on the floor? Unsurprisingly, it is likely to be tensegrity. For a long time, biologists ignored the mechanical properties of cells: they were just ‘elastic bags’ full of interesting chemicals. But there has to be an architecture; tissue is tough, resilient stuff that keeps its shape.
- F. The human body is certainly a tensegrity structure; it consists of 206 bones — tensegrity rods — that do not touch, held together by tendons and muscles. And the tension of living cells seems to be maintained by tensegrity structures within the cell; microfilaments play the role of the rubber bands and stiff microtubules are the rods. Donald Ingber, at the Harvard Medical School, researches how cells move and stick to each other, and he believes that tensegrity offers ‘the most unified model of cell mechanics’. It explains some basic properties of cells very well.

- G. If cells are placed on a microscope slide, they flatten under gravity. When cells are surrounded by other cells, proteins called integrins attach one cell to another at specific locations. These act as tensegrity wires, pulling the cells taut in all directions. When the integrin network is disrupted, the cells sag. Whether or not the cell is a tensegrity structure is still controversial, but in a series of recent papers, Ingber and his team have been gradually picking off the objections with detailed studies of cell structure. For the lay observer, pictures of a cell showing triangular structures resembling a geodesic dome are highly suggestive of tensegrity.
- H. It has been a long road since Black Mountain College in 1948, but it all comes back to Kenneth Snelson and his sculpture. Once asked what he would save from a fire in his office, Donald Ingber replied: `The tensegrity model made by Kenneth Snelson, a gift from the artist himself.

**Questions 1-3:**

According to the information in the Reading Passage, when were the following made?

- the 18<sup>th</sup> century
- the first half of the 20<sup>th</sup> century
- the second half of the 20<sup>th</sup> century
- the 21<sup>st</sup> century

Write the correct letter A, B, C, or D next to questions 1-3.

- an advance in biology based on tensegrity principles
- a work of art based on tensegrity principles
- a building based on tensegrity principles

**Questions 4-10:**

The Reading Passage has eight paragraphs, A-H. Which paragraph contains the following information? NB You may use any letter more than once.

- an error made by the inventor of tensegrity
- the branch of science on which tensegrity is currently having the greatest impact
- the writer's surprise that tensegrity remained unknown in engineering
- an account of how a sculpture was made
- an unresolved issue concerning the nature of individual cell structure
- an explanation of why a basic tensegrity structure keeps its shape
- an analogy between components of a tensegrity model and a skeleton

**Questions 11-14:**

Answer the questions with words from the Reading Passage. Write NO MORE THAN THREE WORDS for each answer.

- Who first used the word 'tensegrity'?
- Which parts of the tensegrity model prevent the straws losing their shape?
- Which parts of a cell hold its microtubules in place?
- What substances join cells to each other?

Passage 2

**The Lost Civilization of Peru**

Two thousand years ago, a mysterious and little known civilization ruled the northern coast of Peru. Its people were called the Moche. They built huge and bizarre pyramids that still dominate the surrounding countryside — some well over a hundred feet tall. Many are so heavily eroded they look like natural hills. Only close up can you see they are made up of millions of mud bricks. Several of the pyramids, known as 'huacas', contain rich collections of murals depicting both secular and sacred scenes from the Moche world. Others house the elaborate tombs of Moche leaders.

Out in the desert, archaeologists have also found the 2,000-year-old remains of an extensive system of mud brick aqueducts which enabled the Moche to tame their desert environment. Many are still in use today. As archaeologists have excavated at Moche sites they've unearthed some of the most fabulous pottery and jewellery ever to emerge from an ancient civilization. The Moche were pioneers of metal-working techniques like gilding and early forms of soldering. These skills enabled them to create extraordinarily intricate artefacts: ear studs and necklaces, nose rings and helmets, many heavily inlaid with gold and precious stones.

But it was the pottery that gave the archaeologists their first real insight into Moche life. The Moche left no written record but they did leave a fabulous account of their life and times in paintings on pots and vessels. Many show everyday events and objects such as people, fish, birds, and other animals. Others show scenes from what, at first sight, look like a series of battles. But as the archaeologists studied them more closely they realized they weren't ordinary battles: all the soldiers were dressed alike; the same images were repeated time and again. When the battle was won, the vanquished were ritually sacrificed. It was, the archaeologists slowly realized, a story not of war but ritual combat followed by human sacrifice.

But what did it mean? The first breakthrough came when Canadian archaeologist Dr Steve Bourget, of the University of Texas in Austin, discovered a collection of bones at one of the most important Moche huacas. Many of the skeletons were deeply encased in mud which meant the burials had to have taken place in the rain. Yet in this part of Peru it almost never rains. Bourget realized there had to be a deliberate connection between the rain and the sacrifices. It led him to a new insight into the Moche world. The Moche, like most desert societies, had practised a form of ritual designed to celebrate or encourage rain. The sacrifices were about making an unpredictable world more predictable. A harsh environment had moulded a harsh civilization with an elaborate set of rituals designed to ensure its survival.

These discoveries answered one question — what the painted scenes were all about- but still left a central riddle. Why had Moche society finally collapsed? Clues came first from climate researchers gathering evidence of the region's climatic history, which suggested that at around AD 560 to AD 650 there was a thirty-year period of exceptionally wet weather, followed by a severe drought lasting another thirty years.

Then archaeologists found evidence of enormous rain damage at a Moche site called Huancaco. New building work had been interrupted and torn apart by torrential rain, and artefacts found in the damaged area dated to almost exactly that period. Next, evidence of drought was discovered. Huge sand dunes appeared to have drifted in and engulfed a number of Moche settlements around AD 600 to AD 650. The story all fitted together. The evidence suggested the Moche had been hit by a double whammy: a huge climate disaster had simply wiped them out. For several years this became the accepted version of events; the riddle of the Moche had been solved.

There was only one problem. In the late 1990s, American archaeologist Dr Tom Dillehay revisited some of the more obscure Moche sites and found that the dates didn't match the climate catastrophe explanation. Many of these settlements were later than AD 650, so clearly the weather hadn't been the immediate cause of their demise. He also found that, instead of constructing huge huacas, the Moche had started building fortresses. They had been at war. But who with? Searching the site for clues, Dillehay's team were

unable to find any non-Moche military artefacts. It could only mean one thing: the Moche had been fighting amongst themselves.

Dillehay now put together a new theory. The Moche had struggled through the climatic disasters but had been fatally weakened. The leadership, which at least in part claimed authority on the basis of being able to determine the weather, had lost its control over the population. Moche villages and clan groups turned on each other in a battle for food and land. This escalated to the point where the Moche replaced ritual battles and human sacrifices with civil war. Gradually they destroyed their own civilization.

Today, after 1,500 years, the Moche and their legacy are beginning to take their place in world history. The story of the Moche is an epic account of a society that thought it could control the world and what happened to it when it found it couldn't. It is a story of human achievement and natural disaster, human sacrifice and war.

**Questions 15-19:**

Do the Following statements agree with the information given in the Reading Passage?

Write

TRUE	if the statement agrees with the information
FALSE	if the statement contradicts the information
NOT GIVEN	if there is no information on this

15. Chiefs are buried in some pyramids.
16. Moche water channels have lasted to the present day.
17. Archaeologists found evidence that the Moche used money.
18. Texts in the Moche language were discovered.
19. Pottery designs had scenes of the Moche fighting foreign armies.

**Questions 20-24:**

Complete the notes. Choose **NO MORE THAN THREE WORDS AND/OR A NUMBER** from the Reading Passage for each answer.

20. The aim of the killings and burials was to make it more likely there would be
21. The extremely dry weather led to some Moche sites being covered by
22. It was thought their civilization had been destroyed by changes in the
23. Dillehay found evidence that Moche society had survived beyond
24. The first evidence of military activity was the discovery of

**Questions 25 - 27:** Which **THREE** of these reasons does Dillehay suggest contributed to the disappearance of the Moche civilization?

- A. a disastrous war with an external enemy
- B. six decades of extreme weather
- C. people no longer obeying their leaders
- D. declining religious belief
- E. the practice of sacrificing people
- F. armed conflict within Moche society

**Passage 3**

## Hyperpolyglots

### A case of brainpower or hard work?

In 1996, DICK HUDSON, a professor of linguistics at University College London posted an email to a listserve for language scientists asking if anyone knew who held the world record for the number of languages they could speak. Replies listed the names of well-known polyglots, such as Giuseppe Mezzofanti, an eighteenth-century Italian cardinal.

Then, in 2003, Hudson received an unexpected reply to his email from someone who had belatedly come across his question. The writer, 'N', described how his grandfather, who was Sicilian and had never gone to school, could learn languages with such remarkable ease that by the end of his life he could speak seventy, and read and write fifty-six. N's grandfather was twenty when he moved to New York in the early 1900s. There he worked on the railways, which brought him into contact with travellers speaking many languages. When N was ten, he accompanied his grandfather on a cruise which took them to over twenty countries, from Venezuela to I-long Kong and Japan. N claimed that whatever port they visited, his grandfather knew the local language.

When Hudson read N's note, he immediately recognized the potential significance of the claims and posted them on the Internet. In his posting, he coined the term 'hyperpolyglot', which he defined as someone who speaks six languages or more.

Language is known to be part of humans' unique cognitive endowment, and scientists have long studied how language abilities can be impaired by disease or trauma. It is less clear, however, what upper limits this endowment has. After a long silence on this topic, linguists and psychologists are now looking to hyperpolyglots for answers. Do these people possess extraordinary brains, or are they ordinary folk with ordinary brains who do something extraordinary through motivation and effort?

Until recently, there was little scientific information about hyperpolyglots. Mezzofanti, for example, was supposed to have known seventy-two languages, and to have spoken thirty-nine fluently, but nowadays such tales are often greeted with scepticism. In the discussion that followed Hudson's publication of N's claims, a reader disputed the Mezzofanti story, saying he found it absolutely preposterous, and pointing out how long it would take to learn seventy-two languages. Assuming that each language has 20,000 words and that Mezzofanti could remember a word after encountering it once, he would have to learn one word a minute, twelve hours a day for five-and-a-half years! Professional linguists, too, are divided on this question. Philip Herdina, at the University of Innsbruck in Austria, is a sceptic. He doubts whether anyone has the capacity to speak seventy-two languages, arguing that maintaining this ability would take resources from other activities.

But others see no reason why people should not be able to learn a huge number of languages. 'There is no limit to the human capacity for language except for things like having time to get enough exposure to the language,' says Suzanne Flynn, a psycholinguist at Massachusetts Institute of Technology. Harvard University psycholinguist Steven Pinker agrees. Asked if there was any reason someone couldn't learn dozens of languages, he replied: 'No theoretical reason I can think of, except, eventually, interference; similar kinds of knowledge can interfere with one another.'

But if Flynn and Pinker are correct, and an ability to learn many languages is the norm, why are so few people able to exploit it? Stephen Krashen, from the University of California, maintains that exceptional language learners simply work harder, and have a better understanding of how they learn. Krashen cites the case of Lomb Kato, an eighty-six-year-old Hungarian interpreter who could speak sixteen languages. Lomb apparently felt she had no special talent for languages: she had taken classes in Chinese and Polish, but the others she taught herself. According to Krashen, Lomb was an ordinary person with no special qualities, apart from a desire to learn languages and an effective way of achieving this aim.

Other researchers say that exceptional brains play a more significant role. In the 1980s, neurolinguist Loraine Obler of the City University of New York found a talented language learner she called 'CJ', who could speak five languages. CJ had learned to read late, had an average IQ, and had always been a mediocre student. However, on the Modern Language Aptitude Test, he scored extremely high. His verbal memory was very good, he could remember lists of words for weeks, but he quickly forgot images and numbers, and had problems reading maps. All of this seemed to indicate that CJ's language talent was inborn and not related to a higher level of general intellectual ability.

Some researchers also believe that there is a genetic component to hyperpolyglottism, and evidence suggests that the trait runs in families. Unfortunately, however, it is difficult to get families to agree to subject themselves to a genetic study. Neither 'N' nor his family were prepared to grant an interview on the subject. What makes this particularly frustrating for linguists trying to study hyperpolyglottism is that, in his original message, N mentioned another member of his family, a seven-year-old girl, who could count to 100 in three languages and could pick out words spoken in other languages and say what they meant.

N and his hyperpolyglot family may have retreated from public view for now, but they could yet provide more fascinating insights into our language abilities.

**Questions 28-32:**

Look at the following list of statements (1-5) relating to hyperpolyglottism. Match each statement with the correct person A-E.

28. Successful language learning requires motivation, application, and a learning strategy.
  29. Speaking many languages would adversely affect other abilities.
  30. Effective learning requires sufficient close contact with a language.
  31. Language aptitude is probably inherited, not a facet of intelligence.
  32. As someone learns more languages, they may get them confused.
- A. Loraine Obler
  - B. Philip Herdina
  - C. Stephen Krashen
  - D. Steven Pinker
  - E. Suzanne Flynn

**Questions 33-38:**

Complete the summary. Choose NO MORE THAN TWO WORDS AND/OR A NUMBER from the article for each answer.

N came from a family which was partly of (33) ..... origin. The evidence of unusual linguistic ability came from two relatives. The first was N's (34) ..... who was said to speak (35) ..... languages. N witnessed this ability during a tour of more than (36) ..... . The second relative, a young girl, could count well in (37) ..... . Research came to an end since N's family would not agree to (38) ..... If true, N's story supports the idea that hyperpolyglottism (39) .....

**Questions 40- 41:**

Which TWO of statements A—E reflect linguists' knowledge of hyperpolyglottism?

- A. They do not know how many languages humans are capable of learning.
- B. They know that people become hyperpolyglots because of a need to know many languages.
- C. They know how hyperpolyglottism is passed on from one generation to the next.
- D. They know that hyperpolyglots have above-average intelligence.
- E. They know that humans are capable of learning many languages.

## IELTS Resource Pack Reading 1

### READING PASSAGE 1

### Questions 1-6

Reading Passage 1 has seven paragraphs, A-G. Choose the most suitable heading for paragraphs B-G from the list of headings below.

#### List of Headings

- i. Getting the agricultural industry to help
- ii. Keeping bumblebees away from gardens
- iii. Effects of the disappearance of bumblebees
- iv. The importance of gardens
- v. Getting help from TV programmes about gardening
- vi. Obtaining wildflower seeds from the countryside
- vii. Obtaining wildflower seeds
- viii. The economic importance of bumblebees
- ix. The future of bumblebee conservation
- x. The necessary conditions for bumblebee conservation
- xi. Why farming is killing bumblebees

#### Example

#### Answer

#### Paragraph A

iii

1. Paragraph B
2. Paragraph C
3. Paragraph D
4. Paragraph E
5. Paragraph F
6. Paragraph G

## Bumblebee Conservation

- A. Bumblebees are major pollinators of a majority of our flora. If bumblebees continue to disappear, these plants will produce less seed, potentially resulting in gradual but sweeping changes to the countryside. It may ultimately become dominated by an entirely different suite of plants that do not require bumblebee pollination. Clovers, vetches, and many rare plants may disappear. Indeed, there is evidence that this process is already underway. These changes will have catastrophic knock-on effects for other wildlife dependent on these plants. As such, it is often argued that bumblebees are a keystone species, and that they are a conservation priority.
- B. Bumblebees are also of commercial importance, being vital to the agricultural industry. Many arable and horticultural crops depend on bumblebees for pollination to varying degrees. Some, like oilseed rape, can produce adequate seed without bumblebees provided there are sufficient honeybees, but others, such as raspberries and several types of bean, are heavily dependent on bumblebees; without them there would be little or no crop to harvest. There is already evidence that in some regions where fields are large and there are few hedgerows (in which bumblebee queens forage in spring and build their nests), crop yields are depressed due to a shortage of bumblebees.
- C. It is thus essential that we take measures to conserve our remaining bumblebee populations, and if possible restore them to something like their past abundance. This cannot be achieved with existing nature reserves. Bumblebee nests are large, containing up to 400 sterile workers, each of which travels more than 1 km from the colony in search of suitable flowers. Each nest needs many hectares of suitable flower-rich habitat, meaning that to support a healthy population which is viable in the long term, large areas of land must be managed sympathetically. UK nature reserves are simply too small. The only way to provide sufficient areas of habitat for bumblebees is if the wider, farmed countryside, and the vast areas covered by suburban gardens, are managed in a suitable way.
- D. To achieve this, farmers should be encouraged to adopt wildlife-friendly farming methods through uptake of the Entry Level Stewardship scheme (ELS). The replanting of hedgerows and the recreation of hay meadow and chalk grassland habitats need to be supported. These activities will not be at the expense of farming, but will actually benefit it, by improving crop yields at the same time as enriching the countryside. Meanwhile, in gardens nationwide,



wildflowers and traditional cottage-garden plants can be used to help increase bumblebee populations.

- E. Many wildflowers have become more scarce in farmland, through loss of hedgerows, hay meadows, chalk grassland, and because of pesticide use. As a result, gardens have become a stronghold for some bumblebee species, for they can provide a wealth of flowers. Throughout the UK, it should be possible to attract at least 6 bumblebee species to a garden, and perhaps as many as 10. Some of the rarer species tend not to visit exotic garden flowers, preferring native British wildflowers. Many of these thrive and look superb in a garden. They are also easy to grow, generally being hardy and much more resistant to slugs, mildew etc. than exotic garden flowers. Most of these plants will also attract a range of other interesting insects to the garden, including butterflies and honeybees.
- F. Seeds of some wildflowers such as foxgloves and cowslips can readily be bought in most garden centres, but the range is usually very limited. A far greater selection is available by mail order from specialist companies. However, there is much to be said for collecting the seeds yourself from the wild. Collecting a handful of seeds will have no impact on the plant population in most cases, and there is a strong conservation argument for use of local seed; it helps to propagate and conserve the local race of the plant species. Using locally-collected seed ensures that the plants grown are adapted to local conditions, and they are more likely to flourish. Introduce a poorly adapted race from miles away and not only are they less likely to survive, but they may also interbreed with wild plants nearby and water-down the unique genetic character of the local race. So if possible, wildflower seeds should be gathered from close to home. This of course also has the added advantage that it is free!
- G. Collecting seeds requires patience. Wildflower seeds are available commercially all year round, but when collecting them from the wild it is necessary to wait for the right time of year. Most wildflower seed is very easy to collect. Generally it is best to sow the seeds immediately, since this is the time at which they would naturally be scattered on the ground near the parent plant.

#### Questions 7-10

Choose the correct letter, A, B, C or D.

7. According to the information in the text, the decline of bumblebees will
- cause the extinction of other species.
  - cause serious problems for gardeners.
  - cause significant environmental problems.
  - cause farmers to go out of business.
8. According to the information in the text, problems caused by the decline of bumblebees
- will start to occur soon.
  - may have started to occur.
  - have started to occur.
  - are already quite serious.
9. According to the information in the text, farmers should be encouraged to
- recreate bumblebee habitats.
  - spend money on conservation.
  - introduce bumblebees to their land.
  - use more traditional farming methods.
10. According to the information in the text, collecting wildflower seeds from the wild
- is easier than buying them.
  - has great benefits for the environment.
  - can be done all year round.
  - should preferably be done locally.

#### Questions 11-13

YES

NO

NOT GIVEN

Do the following statements reflect the claims of the writer?

if the statement reflects the claims of the writer

if the statement contradicts the claims of the writer

if it is impossible to say what the writer thinks about this

- Simple and cost-effective measures will reverse bumblebee decline.
- Ordinary people can do much to help the bumblebee.
- Most people are unaware of the value of bumblebees.

## READING PASSAGE 2

### Questions 14-17

Reading Passage 2 has five sections, A-E. Choose the most suitable heading for sections B-E from the list of headings below.

#### List of Headings

- i. Marketing gemstones
- ii. Present day mining
- iii. Early mining techniques
- iv. The future of the Australian industry
- v. Introduction
- vi. Australia's domestic sapphire trade
- vii. Part of the global sapphire industry
- viii. The mass-market jewellery industry

#### Example

#### Answer

Section A

v

14. Section B

15. Section C

16. Section D

17. Section E

## The Australian sapphire-mining industry

A

Sapphires are traditionally thought of as blue. However, they actually come in a wide variety of colours. Another misconception is that sapphires are more common than diamonds. Although the laws of supply and demand ensure a higher price for diamonds, sapphires are in fact four times rarer.

The mineral name is corundum. (Rubies are the same mineral, but in a red form). The colour variations in sapphires are caused by traces of mineral impurities within the corundum.

The sapphire is the traditional birthstone for September. It is also associated with 45th wedding anniversaries. The principal use of sapphires is of course in jewellery. Sapphires are very durable - only slightly less hard than diamonds - which make them ideal for jewellery which is designed to be worn on a daily basis. Especially popular are rings which combine sapphires with diamonds, often with stunning effects.

B

Sapphires occur principally in the alluvial gravels found in streams and underground drainage networks. In the early days of the industry, sapphire mining was largely done using manual techniques and simple hand tools. Surface or shallow deposits were raked by hand, and potentially sapphire-bearing material was picked out manually and sieved at the point of collection to separate out any gems.

Hand mining techniques were also used underground. Material excavated from mine shafts was loaded into buckets and raised to the surface with hoisting equipment.

Testing for deposits was done by sinking exploratory shafts. This was erratic, and had a low success rate, with sapphire deposits often being missed because of the limitations of the testing process.

C

In underground mining, modern hand-mining techniques are surprisingly similar to the methods used by the early miners. Naturally, though, nowadays these are supplemented by an array of mechanical methods involving powered machinery. In particular, the washing and separation of mined material is now almost entirely mechanised. In Australia, however, in order to preserve the quality of subterranean sapphire-bearing environments, the use of machinery is in many cases limited under state mining laws. The use of mechanical diggers and tunnelling machines is not generally permitted, for example.

Australian open-cut mining operations are not subject to the limitations described above. They tend to employ heavy earth-moving machinery to remove layers of topsoil in order to access the gem-bearing gravel layer below.

**D**

Sapphire mining operations in Australia began in the late 19th century, and Australia has become a major producer of gem-quality sapphires, supplying markets throughout the world. Today, the bulk of commercially-mined sapphires from Australia are sent to Thailand and Sri Lanka for treatment and cutting. Attempts to relocate processing back to Australia have met with only limited success, due largely to the lower labour costs and wider range of established facilities in the countries traditionally associated with gemstone processing.

Smaller stones are cut into calibrated sizes to supply the mass-market jewellery industry. The finest quality sapphires and unusual stones mostly find their way to niche markets in Europe and the United States.

**E**

In the late 1980s Australia produced around 70% by volume of the world's sapphires. Production has decreased considerably since then, but international demand for Australian sapphires remains relatively high. Although further production can be expected from existing fields, continued exploration and testing will be necessary if Australia is to continue to meet present levels of international demand into the long-term future.

Another factor which may influence the long-term prospects of the industry are rising production costs. In recent years miners in Australia have become responsible for addressing the environmental effects of mining operations, and have been liable for costs incurred in rehabilitating land environmentally degraded by their activities. This has rendered the industry vulnerable to competition from other sapphire producing countries where environmental regulations are less stringent. To offset this, the Australian sapphire mining industry must look to marketing strategies and value-adding techniques to ensure that the industry continues to be economically viable.

#### Questions 18-22

Do the following statements agree with the information given in the passage? Write

**TRUE** if the statement agrees with the information  
**FALSE** if the statement contradicts the information  
**NOT GIVEN** if the information is not given

18. Sapphires are rarer and often more expensive than diamonds.
19. Sapphires and rubies are composed of the same substance.
20. Sapphires are mostly found in or near water.
21. Sapphires are probably the most difficult gem to mine.
22. Most of the best Australian sapphires are made into jewellery for sale in Australia.

#### Questions 23-28

Based on the information in the passage, classify the following statements.

- A. Describes the Australian sapphire mining industry in the past only.
- B. Describes the Australian sapphire mining industry in the present only.
- C. Describes the Australian sapphire mining industry in the past and present.
- D. Does not describe the Australian sapphire mining industry, past or present.

Write the correct letter, A, B, C or D, in boxes 23-28 on your answer sheet.

23. Sapphires collected by simple manual methods.
24. Production of more than two thirds of the world's sapphires.
25. Underground mining mostly done with heavy machinery.
26. Cutting of the stones mostly done overseas.
27. Known fields nearly exhausted.
28. Financial disaster very near.

Academic Reading Passage 3:

## **Partnerships in Urban Regeneration**

In recent years, partnerships have become something of a buzzword in urban regeneration. An example are the university partnerships in the USA, where the Ministry of Housing has launched a programme called Community Outreach Partnership. The idea is that members of American universities should take a closer look at the areas surrounding their campuses, where they may discover decayed areas with complex social and economic problems. This programme aims to stimulate an improved basis for planning in these areas. Objectives include improved housing conditions, improved physical health of the local population, and the strengthening of local business activities. These objectives are based on the needs of the local area. University interests are not intended to dominate the partnership. If anything, the opposite is true - universities are encouraged to put their considerable resources of expertise into the service of the surrounding area.

The basis of these partnerships is a contract. The parties to the contract are the Ministry of Housing, the university and the local community. For the partnership to be viable, at least three faculties in the university must participate. A centre is then set up where local residents can obtain free advice and guidance from experts and students involved in the project.

The above is just one example. Comparable partnerships have had considerable successes across the USA, northern Europe and other parts of the world.

A key idea behind such partnerships is the gathering together of the various stakeholders in the local community in order to generate improvements that will benefit all, and are greater than anyone partner could have achieved alone.

Representatives from the public sector, trade and industry and the local community meet and set common goals. Initiatives for greater efficiency and better utilisation of resources are developed. Members of the partnership gain new perspectives on local issues, and innovative solutions result.

Experience has shown that a great deal can be achieved in this way, especially when local businesses are involved. Results have taken the form of falling unemployment, improvements in education, benefits for local industries and improvements in local services. A potential danger of partnerships is that the stronger parties (which are usually businesses, as they tend to possess a much greater share of the material resources) take control. It is therefore important that from the very beginning of the partnership it is clear what power and authority each of the partners will have. Without this measure, there is a risk of local residents feeling that they have no real influence. If the partnership is to be successful, the residents must be fully involved, and must have a sense of ownership of the project, and an understanding of how decisions are made.

Based on experiences gained from urban regeneration partnerships around the world, the following conclusions can be drawn.

1. A partnership is simply a means to a common end, and there should be written definitions of objectives and a set of rules. However, formal contracts can be too binding. There should be some element of freedom to allow the development of a creative synergy.
2. It is essential that all partners have the same objectives. These should be clearly identified and also prioritised from the outset to prevent possible conflicts regarding the deployment of resources.
3. Public sector institutions such as local councils must undertake to make stable, long-term contributions to the development of the project.
4. The activities of different public sector bodies must be effectively coordinated.
5. The residents must be among the key participants in the project. To facilitate this, if one doesn't already exist, a local organisation must be set up.
6. The number of stakeholders should be kept to a minimum. The interests of partners, and powers behind them, should be included in the analysis of any proposed partnership.

7. People with appropriate skills and experience should be appointed to the administrative roles created by the new partnership. The main aim of such people should be to facilitate effective collaboration between the partners.
8. As well as long term strategies, it is a good idea to aim for some short term and highly visible results. This creates impetus and strengthens the motivation of the people involved.
9. Time and resources should be set aside for celebrating the achievements and milestones of the project. This can be of great importance to the success of a partnership

#### Questions 29-32

Choose the correct letter, A, B, C or D.

29. In the USA, Community Outreach Partnerships
  - A. have become a buzzword.
  - B. are based on a contract.
  - C. aim to improve local university facilities.
  - D. can solve most local problems.
30. In Community Outreach Partnerships, local people
  - A. are invited to attend university classes.
  - B. give advice to students.
  - C. are offered jobs in local universities.
  - D. can get advice from students.
31. Partnership administrators should
  - A. organise collaboration between partners.
  - B. aim for immediate results.
  - C. be kept to a minimum.
  - D. analyse the partners' interests.
32. Celebrating the successes of the project
  - A. is essential for local residents.
  - B. should not take up too much time.
  - C. is a good use of resources.
  - D. should be kept to a minimum.

#### Questions 33-36

Choose ONE phrase from the list of phrases A-I below to complete each of the following sentences.

33. Urban regeneration partnerships ...
34. Local businesses ...
35. Local residents ...
36. Public sector institutions ...
  - A. principally benefit students at local universities.
  - B. must not be allowed to dominate.
  - C. produce good results by involving all concerned parties in the project.
  - D. should be given financial incentives to participate.
  - E. are most successful when they are based on a contract.
  - F. must provide appropriate support.
  - G. should not be allowed to participate in the partnership.
  - H. must fund improvements in local education and services.
  - I. must feel that they are central to the project.

#### Questions 37-40

Complete the notes below. Choose NO MORE THAN FOUR WORDS from Reading Passage 3 for each answer. Write your answers in boxes 37-40 on your answer sheet.

Four benefits of urban regeneration partnerships:

- They can be more efficient, bringing about better 37.....
- There may be a reduction in 38.....
- Partners may develop 39.....on local issues.
- The results can be better than one partner 40.....

IELTS Resource Pack Reading 2**The Royal National Lifeboat Institution at Lyme Regis**The Early History

Only two years after the foundation of the Royal National Institute for the Preservation of Life from Shipwreck in 1824, Lyme Regis was fully recognised as a town that needed a lifeboat.

This need had been originally highlighted in the November of 1824 when, during a tremendous storm, the lives of the crew of the barque Unity were saved by local men at Black Ven, east of the town. The actions of three of the rescuers gained recognition in the awarding of a gold medal and two silver medals respectively. These were some of the first RNLI medals to be awarded.

Early in 1825, a Coastguard Captain named Richard Spencer altered a local boat by fitting airtight compartments and cork fendering so that it could be used as a "proper" lifeboat. The organisation that we now know of as the RNLI (since 1854) was pleased with Spencer's experiments and in 1826 brought the saving of life at sea under its auspices.

From 1826 to 1852 the station was served by two locally converted vessels, but no records exist as to their names. It was the events of Boxing Day 1852 that stimulated the need for a purpose-built lifeboat in the town, when four of the five lifeboatmen perished on service to the barque Heroine carrying emigrants bound for Australia.

The following years saw two 8m "Peake Plan" lifeboats at the town and in 1866 the first named lifeboat, the William Woodcock, was placed on station. The 10m vessel carried out 7 rescue call-outs and was replaced in 1891 by the Susan Ashley and then by the Thomas Masterman Hardy in 1915. In all, these five sailing and rowing lifeboats carried out 32 call-outs before the station was closed in 1932, as motorised lifeboats from Exmouth and Weymouth were believed to be able to cover the area.

In 1937, and with only local boats once again acting as lifeboats, the Royal Air Force Marine Craft Unit came to the town and operated their fast patrol and safety launches from the site of what is now the Marine Centre west of Monmouth Beach. The Royal Air Force unit was closed in 1964. With the boom in boating as a recreation, and Lyme Regis now a thriving holiday resort, the town was yet again without a lifeboat: but after long discussions and hard fundraising, June 10th 1967 saw the re-opening of an RNLI lifeboat station in the town and almost 900 call-outs later, it is still operating to this day.

Awards for Gallantry

There have been many services at Lyme Regis that have been recognised by awards: in total, 1 Gold, 7 Silver and 3 Bronze Medals since 1825. The most prestigious in recent years being in August 1979 when helmsman John Hodder with his crew of three rescued a party of five persons (including a small boy) from their yacht White Kitten in storm force conditions. John Hodder and crewman Colin Jones (who single-handedly sailed the yacht to the safety of the harbour) were each awarded the Bronze Medal and the crew were also presented with the Ralph Glister Award for the most meritorious rescue by an inshore lifeboat that year.

The Lifeboat Today

The lifeboat now stationed here was funded almost entirely by local donations and came into service on 29th September 1997. She is a longer, wider and more powerful successor to the Atlantic 21 being powered by twin 70h.p. engines giving a maximum speed of 34 knots. Pearl of Dorset is fitted with a satellite navigation system, VHF radio, righting capability in the event of a capsize, and first aid equipment. The crew is normally three, including the helmsman.

The boat is launched from its DO-DO trolley (meaning Drive On, Drive Off). This is manoeuvred by a semi-submersible tractor enabling speedy launches particularly at low water. The station prides itself on an average launch time from initial call to leaving the harbour of just seven minutes. Each year the lifeboat launches over one hundred times on rescue call-outs and exercises, many of which involve other rescue services.

### Lifeboatmen Today

Today's volunteer life boatmen here come from all walks of life. Only two of the crew of fourteen are professional seafarers: the rest are made up of such professions as teachers, market gardeners, engineers, builders and chefs. The crew are supported by a similar number of people on the shore acting as mechanics, tractor drivers, radio operators and other invaluable shore helpers. They are all dedicated to the saving of life at sea and can only do so by the continued support of the public.

### Questions 1-5

Look at the events and dates below. Match one date to each event. Use each date **ONCE ONLY**

Write your answers in boxes 1-5 on your answer sheet.

1. A lifeboat service was provided by the armed forces.
2. Several lifeboatmen died carrying out a rescue.
3. The first dedicated lifeboat was created.
4. The lifeboat service was relocated to other coastal towns.
5. The Royal National Institute for the Preservation of Life from Shipwreck changed its name.

1824	1825	1852	1854	1866	1932	1937	1964	1967
------	------	------	------	------	------	------	------	------

### Questions 6-8

Choose the correct letter, A, B, C or D. Write the correct letter in boxes 6-8 on your answer sheet.

6. The current lifeboat was mostly paid for by
  - A. the local council.
  - B. local people.
  - C. the crew.
  - D. the RNLI.
7. The current lifeboat is launched
  - A. from a trolley.
  - B. from a larger boat.
  - C. in shallow water.
  - D. in under seven minutes.
8. John Hodder won a medal for
  - A. rescuing so many people.
  - B. skilful sailing in bad weather.
  - C. sailing single-handed.
  - D. rescuing a small boy.

### Questions 9-13

Do the following statements reflect the claims of the writer? Write

YES if the statement reflects the claims of the writer  
 NO if the statement contradicts the claims of the writer  
 NOT GIVEN if it is impossible to say what the writer thinks about this

9. Richard Spencer's lifeboat saved many lives.
10. Lyme Regis has had its own lifeboat service since 1937.
11. The lifeboat service is important to the local economy.
12. The present lifeboat will not sink if it turns over in the water.
13. Lifeboat men come from a wide variety of backgrounds.

## Academic Reading Passage 2:

**Testing Animal Intelligence**

Applying human intelligence tests to animals has been largely discredited, as these are designed to measure human intelligence. Even time-honoured tests like putting rats into mazes can be deceptive, since such tests assume the animals will rely on the same senses as we do. A rat's primary sense organ is its nose, not its eyes. Give a rat a maze of smells, not just visible walls, and it can solve it as fast as a human can.

If intelligence is defined as the ability to cope with everything your environment throws at you, then all surviving species are intelligent. If members of any animal species are required to solve complex problems, many of them will eventually do it.

This implies that animals can be "educated" like people. What seems to differentiate humans is not our mental skills so much as our flexibility and our capability for abstract thought: the ability to create new ideas and images as well as receive them.

Animals can do things like navigating or remembering the locations of objects much better than we can. What they don't do so well is apply reasoning to a whole range of problems, which is one of the things that has made human beings so successful as a species.

Part of the problem in assessing animal intelligence is communication. For example, we can't speak to dolphins, because they can't hear human speech very well. And their own language is so different from ours that it will take years of research and enormous computing power to decipher it. So far, scientists have only identified the names, or 'call-signs', by which dolphins seem to refer to themselves and each other, including 'talking about' other dolphins who aren't present.

The best we can do is to develop a common language of signs. The Dolphin Institute in Hawaii uses more than 100 different hand-signals. Its dolphins can understand not only individual words but also the grammar which links them - the difference between 'take the ball to the surfboard' and 'take the surfboard to the ball', for example - as well as abstract concepts like left and right, yes and no, and questions. If you give them a meaningless command, such as 'take the ball to the surfboard' when there is no surfboard, they take it to a sign meaning 'no', as if to say 'I can't'.

Dolphins seem able to learn independently. For example, they are the only species besides humans which can instantly understand television. They realise it's only a representation of the real world and that they can take instructions from a picture of a trainer on-screen but they can't expect the picture to give them a reward.

The Dolphin institute has even devised a signal meaning "be creative", at which the dolphin will make up some previously unseen behaviour. Combine the signals for "create" and "with another dolphin" and two dolphins can produce an instant synchronised routine. This suggests that they can communicate with one another and either design the routine together or agree that one will be the leader.

In the wild, dolphins cooperate to catch fish by driving them onto a beach, and this behaviour is not restricted to their own species. In Argentina, dolphins collaborate with fishermen to drive fish into the latter's nets, in return for a share of the catch. Each dolphin will only work with a particular fisherman and, when they breed, their offspring work with the same man.

As more research is done, we can increasingly appreciate the complexities of other species' behaviour. Monkeys and apes seldom resort to violence to get their own way, preferring social manipulation and deception. The most successful members of the group tend to be those who are best at soliciting support, or who have the largest families to back up their opinions - not the biggest or strongest as with, say, rutting stags. Research has shown that chimps can perform surprisingly complex sequences of actions to process food, such as collecting a bundle of leaves or cracking nuts with a rock. This implies the ability to plan things in their minds before starting the task, otherwise they might get muddled -



forgetting to place all the leaves the same way round, or find a hard, level resting place for the nut, for instance.

Even sheep, a byword for mindless behaviour, perhaps deserve reappraisal. It has long been known that you can't buy a hill farm without buying the sheep that go with it. The local flock develops an intimate knowledge of the terrain, enabling the sheep to find food in summer and shelter in winter, which is passed down from ewe to lamb for generations. It has discovered that sheep recognise each other's faces, and appear to use the right side of the brain for this, just like people. They can easily distinguish between 50 different faces, which they can remember for at least two years, and can remember the faces of sheep they haven't seen for a while. It is widely assumed that dogs are brighter than sheep. However, in the hills of Gujarat in western India, instead of using sheepdogs to round up their flocks, shepherds call directly to the sheep - and they obey.

#### Questions 14-18

Complete the table below using information from the text.

ANIMAL	SKILL
rats	14 .....
dolphins	15 .....
monkeys and apes	16 .....
sheep	17 .....
all animals	18 .....

- A. can collaborate with each other
- B. can give instructions to other animals
- C. transfer knowledge to their offspring
- D. can recognise many different human faces
- E. use many of the same strategies as humans in their dealings with each other.
- F. solve problems in their daily lives
- G. can create images
- H. can solve certain puzzles very quickly

#### Questions 19-26

Do the following statements reflect the claims of the writer? Write

- YES if the statement reflects the claims of the writer  
 NO if the statement contradicts the claims of the writer  
 NOT GIVEN if it is impossible to say what the writer thinks about this

19. Human intelligence tests are inappropriate for animals.
20. In some cases, animal abilities can be considered superior to human abilities.
21. Animals learn to recognise images more slowly than humans.
22. Human intelligence is more versatile than animal intelligence.
23. Scientists have learned to communicate effectively with dolphins.
24. Dolphins can tell the difference between fact and fiction.
25. Only humans are ever dishonest with each other.
26. We will have a much greater understanding of animal intelligence in the future.

#### Question 27

From the list below, choose the sentence A-D which best summarises the views of the writer.

Write the correct letter, A, B, C or D, in box 27 on your answer sheet.

- A. Scientists are discovering that many animals are much more intelligent than they realised.
- B. Some animals are not actually less intelligent than humans - their intelligences are just different.
- C. We cannot accurately assess animal intelligence, because their intelligences are different to ours.
- D. The only real difference between human and animal intelligence is that we can think creatively.

**READING PASSAGE 3****Questions 28-32**

Reading Passage 3 has five sections, A-F. Choose the most suitable heading for sections B-F from the list of headings below. Write the correct number, i-ix, in boxes 28-32 on your answer sheet.

**List of Headings**

- i. Mismanagement
- ii. Promoting eco-tourism
- iii. A lack of awareness and understanding
- iv. Problems
- v. Re-housing local people
- vi. Conservation and livelihoods
- vii. Solutions and best practices
- viii. Successful development of wetlands
- ix. The value of wetlands

- 28. Paragraph B
- 29. Paragraph C
- 30. Paragraph D
- 31. Paragraph E
- 32. Paragraph F

Example

Paragraph A

Answer

vi

**Wetlands****A**

Millions of people depend for their livelihoods on intact and functioning wetlands. Wetlands provide them with the main resources for their existence, such as water, food and materials. In addition they act as transport corridors and provide protection against floods, drought and saltwater intrusion. Sustainable development therefore means recognising and integrating these environmental values and services into development plans and activities.

Unfortunately the development and aid sector are not always aware of the values and services that wetlands deliver. Similarly, the environment and conservation sector seldom addresses the socio-economic development issues fundamental to sustain people's livelihoods.

Initiatives are necessary to facilitate dialogue between these two sectors in the management of wetlands and their resources, to create and implement a common agenda to produce win-win solutions for biodiversity conservation and people's livelihoods and development.

**B**

Wetlands cover more than 6% of the earth's surface and have extremely important natural functions: they are biodiversity hotspots, help regulate regional ecosystems and play important roles in climate regulation.

Wetlands are also of crucial value to people. Because of the close interaction of water and land, wetlands are highly productive ecosystems with the potential to support large human populations. Many people in the developing world depend on wetlands to realise a sustainable livelihood.

As well as providing water, food and materials, transport corridors and protection against flood, drought and saltwater intrusion (as stated above) wetlands also purify water supplies, sequester carbon dioxide and recharge groundwater reserves. More recently, through eco-tourism and new economic analyses such as BioRights, wetlands have become the focus of innovative conservation-based economic development and poverty reduction opportunities.

In addition to the many ecological amenities, functions and values of wetlands crucial to people's environmental and food security, wetlands also contribute to the cultural and spiritual needs of their inhabitants.

**C**

Wetlands are the most highly threatened of all ecosystems, and pressure on them is likely to intensify over the coming decades due to rapidly increasing water consumption, over-exploitation of natural resources and climate change.

Problems also result from the narrow approaches taken to economic development, economic subsidies which do not consider the link between ecosystem services and human livelihoods, or poorly formulated responses to poverty.

Unsustainable exploitation and the destruction of wetlands is often the result of poor planning, and a lack of recognition of the ecological, hydrological and economic functions and values associated with intact wetlands.

**D**

Policy and decision makers often lack awareness of the interconnection between functioning ecosystems and people's livelihoods, or between environmental degradation and poverty. Regrettably wetlands are often viewed as areas of little or no value, "wastelands" that are available for development or exploitation rather than a resource that, if managed properly, will make a significant contribution to ecosystem and human health.

This is partly because the global biodiversity value of wetland areas is often not expressed in economic terms or social benefits. Another reason is that large-scale development plans are often driven by one sector (e.g. water and sanitation, hydro-electrical or transportation) whereas wetlands are multi-functional ecosystems that can serve a great variety of sectors and stakeholders, if approached in a multi-sectoral manner. In addition, poor people often have no alternative to over-exploitation due to lack of any other means of existence.

**E**

Despite intentions to the contrary, wetlands are frequently improperly managed, leading to the destruction of environmental services and products and a subsequent escalation in poverty among those whose livelihoods are reliant on such products and services.

As a consequence of such mismanagement, the vulnerability of the poorest of the poor increases, leading to a further cyclical decline in opportunities for both environment and people.

**F**

With millions of people directly dependent on wetlands and wetland resources for their livelihoods, it is evident that protecting and restoring wetlands and their multi-functions can help assure people's well-being, and contribute to reducing poverty and poverty vulnerability.

Although wetlands do not provide all that is needed for socially equitable development, there is strong evidence that poverty increases in wetlands that are degraded. Maintaining and restoring wetlands is therefore in the direct interest of the poor.

### **Questions 33-36**

Which **FOUR** of the following sentences match information in the text? Choose **FOUR** letters, A-J.

- A. Wetlands prevent salt water from entering freshwater resources.
- B. Wetlands attract millions of visitors.
- C. Wetlands meet the physical and spiritual needs of their inhabitants.
- D. Wetlands can generate substantial revenue for national economies.
- E. Wetlands replenish supplies of freshwater.
- F. Wetlands can be created out of wastelands.
- G. Wetlands can provide natural products for sale by local businesses.
- H. Wetlands provide habitats for a wide variety of plant and animal species.
- I. Wetlands are cheap to maintain in good condition.
- J. Wetlands provide recreational facilities for people from nearby urban areas.

**Questions 37-40** Complete each sentence with the correct ending, A-I, below.

- |   |
|---|
| <ul style="list-style-type: none"> <li>A. are often neglected by central governments.</li> <li>B. do not always collaborate effectively.</li> <li>C. often have no alternative to degrading the environment.</li> <li>D. are often dominated by a single objective.</li> <li>E. often fail to spend money where it is most needed.</li> <li>F. often fail to appreciate the value of wetlands.</li> <li>G. often protect endangered species.</li> </ul> |
|---|

**37. Environmental organisations and aid organisations**

**38. Development plans**

**39. Decision-makers**

**40. Poor wetland inhabitants**

ACADEMIC READING FROM CAMBRIDGE GRAMMAR  
PASSAGE 1

## JUMPING SPIDERS

*Peter Aldhons examines how Portia Spiders catch their prey*

**A**

For a stalking predator, the element of surprise is crucial. And for jumping spiders that sneak into other spiders' webs to prey on their owners, it can be the difference between having lunch and becoming it. Now zoologists have discovered the secrets of these spiders' tactics: creeping forward when their prey's web is vibrating.

**B**

The fifteen known species of Portia jumping spiders are relatively small, with adults being about two centimetres long (that's smaller than the cap on most pens). They habitually stay in the webs of other spiders, and in an area of these webs that is as out-of-the-way as possible. Portia spiders live mostly in tropical forests, where the climate is hot and humid. They hunt a range of other spiders, some of which could easily turn the tables on them. "They will attack something about twice their own size if they are really hungry," says Stimson Wilcox of Binghamton University in New York State. Wilcox and his colleague, Kristen Gentile of the University of Canterbury in Christchurch, New Zealand, wanted to find out how Portia spiders keep the upper hand.

**C**

All jumping spiders have large eyes that look like binocular lenses and they function pretty much the same way. Most jumping spiders locate their prey visually, and then jump and capture from one centimetre to over ten centimetres away. Only a few species of jumping spiders invade the webs of other spiders, and the Portia spider is among them. Jumping spiders, including Portia spiders, prey on insects and other arthropods by stalking. Sometimes the spiders lure their victims by vibrating the web to mimic the struggles of a trapped insect. But many web-weaving spiders appear to be wise to these tricks, so stalking is often a better strategy. Sometimes, the researchers found, Portia spiders take advantage of the vibrations created in the web by a gentle breeze. But if necessary, they will make their own vibrations.

**D**

The researchers allowed various prey spiders to spin webs in the laboratory and then introduced Portia spiders. To simulate the shaking effects of a breeze the zoologists used either a model aircraft propeller or attached a tiny magnet to the centre of the web which could be vibrated by applying a varying electrical field. The researchers noticed that the stalking Portia spiders moved more when the webs were shaking than when they were still, and they were more likely to capture their prey during tests in which the webs were periodically shaken than in those where the webs were undisturbed. If the spiders were placed into unoccupied webs, they would make no attempts to change their movements.

**E**

It is the Portia spider's tactics of making its victims' webs shake that has most intrigued the researchers. They noticed that the spiders would sometimes shake the quarry's web violently, then creep forwards up to five millimetres before the vibrations died down. "They'd make a big pluck with one of their hind legs," says Wilcox. These twangs were much more powerful than the gentler vibrations Portia spiders used to mimic a trapped insect, and the researchers were initially surprised that the prey spiders did not respond to them in any way. But they have since discovered that the violent twanging produces a pattern of vibrations that matches those caused by a twig falling onto the web.

**F**

Other predators make use of natural ‘smokescreens’ or disguises to hide from their Prey: lions hunting at night, for example, move in on their prey when clouds obscure the moon. ‘But this is the first example of an animal making its own smokescreen that we know of,’ says Wilcox. ‘Portia spiders are clearly intelligent and they often learn from their prey as they are trying to capture it. They do this by making different signals on the web of their prey until the prey spider makes a movement. In general, Portia spiders adjust their stalking strategy according to their prey and what their prey is doing. Thus Portia spiders use trial and error learning in stalking. Sometimes they will even take an indirect route to reach a prey spider they can see from a distance. This can sometimes take one or two hours following a predetermined route. When it does this, the Portia spider is actually solving problems and thinking ahead about its actions.’

#### Questions 1-9

The reading passage has six paragraphs labelled A-F. Which paragraph contains the following information? Write the correct letter A-F next to questions 1-9. NB You may use any letter more than once

1. The reaction of the Portia spider’s prey to strong web vibrations
2. A description of how the researchers set up their experiment
3. A comparison between Portia spiders and another animal species
4. An explanation of how the researchers mimicked natural conditions
5. A comparison between Portia spiders and their prey
6. The reason why concealment is important to Portia spiders
7. A description of the Portia spiders habitat
8. The number of species of Portia spiders
9. An example of Portia spider’s cleverness

#### Questions 10-13

Choose the correct letter A,B,C or D

10. In the laboratory experiments researchers found that the Portia spiders moved most when the web was
  - A. Vibrating
  - B. Motionless
  - C. Undisturbed
  - D. Unoccupied
11. What discovery did the researchers make about the Portia spiders?
  - A. They make very strong vibrations with one leg
  - B. They move 5 mm at a time on a still web
  - C. They move slowly when vibrations stop
  - D. They use energetic vibrations to mimic a trapped insect.
12. Portia spiders are the only known animal to
  - A. Use the weather to disguise themselves
  - B. Mimic other prey eating animals
  - C. Create their own smokescreen
  - D. Stalk using ‘trial and error’
13. The Portia spider demonstrates ‘thinking ahead’ when it
  - A. Chooses prey that is a short distance away
  - B. Takes a longer route to reach its prey
  - C. Reaches its prey in a short time
  - D. Solves the problem of locating its prey

**PASSAGE 2** Read the passage below and answer questions 14-25

## **The History of the Biro**

**A**

One chilly autumn morning in 1945, five thousand shoppers crowded the pavement outside Gimbels Department Store in New York City. The day before, Gimbels had taken out a full page newspaper advertisement in New York Times announcing the sale of the first ball point pens in the United States. The new writing instrument was heralded as “fantastic..... miraculous.....guaranteed for write for two years without refilling!” Within six hours, Gimbels had sold its entire stock of ten thousand ballpoints at \$ 12.50 each – approximately \$ 130 at today’s prices.

**B**

In fact this new pen was not new after all, and was just the latest development in a long search for the best way to deliver ink to paper. In 1884 Lewis Waterman had patented the fountain pen, giving him the sole right to manufacture it. This marked a significant leap forward in writing technology, but fountain pens soon became notorious for leaking. In 1888, a leather tanner named John Loud, devised and patented the first “rolling-pointed marker pen” for marking leather. Loud’s design contained a reservoir of ink in a cartridge and a rotating ball point that was constantly bathed on one side with ink. Loud’s pen was never manufactured, however, and over the next five decades, 350 additional patents were issued for similar ball-type pens, though none advanced beyond the design stage. Each had their own faults, but the major difficulty was the ink: If the ink was thin, the pens leaked, and if it was too thick, they clogged. Depending on the climate or the air temperature, sometimes the pens would do both.

**C**

Almost fifty years later, Ladislav and Georg Biro, two Hungarian brothers, came up with a solution to the problem. In 1935 Ladislav Biro was working as a journalist, editing a small newspaper. He found himself becoming more and more frustrated by the amount of time he wasted filling fountain pens with ink and cleaning up the ink smudges. What’s more, the sharp tip of his fountain pen often scratched or tore through the thin newsprint paper. Ladislav and Georg (a chemist) set about making models of new pen designs and creating better inks to use in them. Ladislav had observed that the type of ink used in newspaper printing dried rapidly, leaving the paper dry and smudge free. He was determined to construct a pen using the same type of ink. However, the thicker ink would not flow from a regular pen nib so he had to develop a new type of point. Biro came up with the idea of fitting his pen with a tiny ball bearing in its tip. As the pen moved along the paper, the ball bearing rotated and picked up ink from the ink cartridge which it delivered to the paper.

**D**

The first Biro pen, like the designs that had gone before it, relied on gravity for the ink to flow to the ball bearing at the tip. This meant that the pens only worked when they were held straight up, and even the ink flow was sometimes too heavy, leaving big smudges of ink on the paper. The Birus had a rethink and eventually devised a new design, which relied on capillary action rather than gravity to feed the ink. This meant that the pens only worked when they were held straight up, and even the ink flow was sometimes too heavy, leaving big smudges of ink on the paper. The Biro brothers had a rethink and eventually devised a new design, which relied on capillary action rather than gravity to feed the ink. This meant that the ink could flow more smoothly to the tip and the pen could be held at an angle rather than straight up. In 1938, as World War II broke out, the Biro brothers fled to Argentina, where they applied for a patent for their pen and established their first factory.

**E**

The Biro’s pen soon came to the attention of the American fighter pilots, who needed a new kind of pen to use at high altitudes. Apparently it was ideal for pilots as it did not leak like the fountain pen and did not have to be refilled frequently. The United States Department of War contacted the several American companies, asking them to manufacture a similar writing instrument in the U.S. thus fortune smiled on the Biro brothers in May 1945, when the American company ‘Eversharp’ paid them \$500,000 for the exclusive manufacturing and marketing rights of the Biro ballpoint for

the North American market. Eversharp were slow to put their pen into production, however, and this delay ultimately cost them their competitive advantage.

F

Meanwhile, in June 1945 an American named Milton Reynolds stumbled upon the Biro pen while on vacation in Buenos Aires. Immediately seeing its commercial potential, he bought several pens and returned to Chicago, where he discovered that Loud's original 1888 patent had long since expired. This meant that the ballpoint was now in the public domain, and he therefore wasted no time making a copy based on the Biro design. Establishing his pen company with just \$26,000, Reynolds quickly set up a factory with 300 workers who began production on 6<sup>th</sup> October 1945, stamping out pens from precious scraps of aluminium that hadn't been used during the war for military equipment or weapons. Just 23 days later, it was Reynolds's ballpoint that caused the stampede at Gimbels Departmental Store. Following the ballpoints debut in New York City, Eversharp challenged Reynolds in the law courts, but lost the case because the Biro brothers had failed to secure a U.S. patent on their invention.

### Questions 14-19

The reading passage has six paragraphs labelled A-F. Choose the most suitable heading for each paragraph from the list. Write the correct number i-ix in the space provided.

- |       |   |
|-------|---|
| i.    | Fountain pens are history                         |
| ii.   | Fame at last for the Biro brothers                |
| iii.  | A holiday helps bring the biro to America         |
| iv.   | A second design and a new country                 |
| v.    | War halts progress                                |
| vi.   | Dissatisfaction leads to a new invention          |
| vii.  | Big claims bring big crowds                       |
| viii. | A government request brings a change of ownership |
| ix.   | Many patents and many problems                    |

- 14) Paragraph A
- 15) Paragraph B
- 16) Paragraph C
- 17) Paragraph D
- 18) Paragraph E
- 19) Paragraph F

### Questions 20-22

Choose the correct answer A, B, C or D.

- 20) The problem with the ballpoint pens invented between 1888 and 1935 was that
- A. they cost a great deal of money to manufacture.
  - B. the technology to manufacture them did not exist.
  - C. they could not write on ordinary paper.
  - D. they were affected by weather conditions.
- 21) The design of the Biro brothers' first pen
- A. was similar to previous pens.
  - B. was based on capillary action.
  - C. worked with heavy or light inks.
  - D. worked when slanted slightly.
- 22) Milton Reynolds was able to copy the Biro Brothers' design because
- A. the Biro brothers' original patent was out of date.
  - B. it was legal to copy other designs at the time.
  - C. they did not have a patent for North America.
  - D. the Biro brothers' gave him permission.

### Questions 23-25

Answer the questions below using NO MORE THAN TWO WORDS AND /OR A NUMBER for each answer.

23) What material was the first ballpoint pen designed to write on? .....

24) Where did the Biro brothers' open their first factory? .....

25) In which year did the first American biro factory begin production? .....

## PASSAGE 3

**DRESSED TO DAZZLE**

As high –tech materials invade high –street fashion, prepare for clothes that are cooler than silk and warmer than wool, keep insects at arm’s length, and emit many pinpricks of coloured light.

The convergence of fashion and high technology is leading to new kinds of fibres, fabrics and coatings that are imbuing clothing with equally wondrous powers. Corpe Nove, an Italian fashion company has made a prototype shirt that shortens its sleeves when room temperature rises and can be ironed with a hairdryer. And at Nexia Biotechnologies, a Canadian firm, scientists have caused a stir by manufacturing spider silk from the milk of genetically engineered goats. Not surprisingly, some industry analysts think high-tech materials may soon influence fashion more profoundly than any individual designer.

A big impact is already being made at the molecular level. Nano-TeX, a subsidiary of American textiles maker Burlington, markets a portfolio of nanotechnologies that can make fabrics more durable, comfortable, wrinkle –free and stain resistant. The notion of this technology posing a threat to the future of the clothing industry clearly does not worry popular fashion outlets such as Gap, Levi Strauss and Lands’ End, all of which employ Nano-TeX’s products. Meanwhile, Schoeller Textil in Germany, whose clients include famous designers Donna Karan and Polo Ralph Lauren. Uses nanotechnology to create fabrics that can store or release heat.

Sensory Perception Technologies( SPT) embodies an entirely an entirely a different application of nanotechnology. Created in 2003 by Quest International, a flavour and fragrance company, and Woolmark, a wool textile organisation, SPT is a new technique of embedding chemical into fabric. Though not the first of this type, SPT ‘s durability ( evidently the icro capsule containing the chemicals can survive up to 30 washes) suggests an interesting future. Designers could incorporate signature scents into their collection. Sportswear could be impregnated with anti perspirant. Hay fever sufferers might find relief by pulling on a T-shirt and so on.

The loudest buzz now surrounds pylactic acid (PLA) fibres- and, in particularly, one brand name Ingeo. Developed by Cargill Dow, it is the first man-made fibre derived from 100% annually renewable resources. This is a currently maize (corn), though in theory any fermentable plant material even potato peelings, can be used. In performance terms, the attraction for the 30- plus clothes makers signed up to use Ingeo lies in its superiority over polyester (which it was designed to replace).

As Philippa Watkins, a textiles, notes, Ingeo is not a visual trend. Unlike nanotechnology, which promises to transform what clothes can do, Ingeo’s impact on fashion will derive instead from its emphasis on using natural sustainable resources.

Could wearing synthetic fabrics made from polluting and non-renewable fossil fuels become as un-cool as slipping on a coat made from animal fur? Consumers should expect a much wider choice of ‘green’ fabrics. Alongside PLA fibres, firms are investigating plants such as bamboo, seaweed, nettles and banana stalks as raw materials for textiles. Soya bean fibre is also gaining around. Harvested in China and spun in Europe, the fabric is a better absorber and ventilator than silk, and retains heat better than wool.

Elsewhere, fashion houses-among them Ermenegildo Zegna, Paul Smith and DKNY- are combining fashion with electronics. Clunky earlier attempts involved attaching electronic components to the fabrics after the normal weaving process. But companies such as SOFT



switch have developed electro-conductive fabrics that behave in similar ways to conventional textiles.

Could electronic garments one day change colour or pattern? A hint of what could be achieved is offered by Luminex, a joint venture between Stabio Textile and Caen. Made of woven optical fibres and powered by a small battery, Luminex fabric emits thousands of pinpricks of light, the colour of which can be varied. Costumes made of the fabric wowed audiences at a production of the opera *Aida* in Washington, DC, last year.

Yet this ultimate of ambitions has remained elusive in daily fashion, largely because electronic textiles capable of such wizardry are still too fragile to wear. Margaret Orth, whose firm International Fashion Machines makes a colour-changing fabric, believes the capability is a decade or two away. Accessories with this chameleon-like capacity- for instance, a handbag that alters its colours – are more likely to appear first.

#### Questions 26-31

Look at the following list of companies (26-31) and the list of new materials below. Match each company with the correct material. Write the correct letter A-H next to the companies 26-31  
NB you may use any answer more than once.

- 26) Corpe Nove .....  
27) Nexia Biotechnologies .....  
28) Nano- Tex .....  
29) Schoeller Textil .....  
30) Quest International and Woolmark .....  
31) Cargill Dow .....

- A) Material that can make you warmer or cooler  
B) Clothing with perfume or medication added  
C) Material that rarely needs washing  
D) Material that can change according to external heat levels  
E) Material made from banana stalks  
F) Material that is environmentally –friendly  
G) Fibres similar to those found in nature  
H) Clothes that can light up in the dark

#### Questions 32-39

Complete the summary below. Write NO MORE THAN TWO WORDS from the reading passage for each answer.

#### Major changes in fabrics

##### Using plants

Nanotechnology will bring changes we can see, while the brand called 32).....will help the environment. Fibre made from the 33).....plant has better qualities than silk or wool.

##### Electronics

In first attempts to use electronics, companies started with a material made by a standard 34).....method and then they fixed 35).....to the material.

##### Luminex fabric

- Needs a 36).....to make it work.
- Has already been used to make stage 37).....
- Is not suitable for everyday wear because it is too 38).....

The first products that can change colour are likely to be 39).....

## 404 Test 4

## READING PASSAGE 1

**THE LIFE CYCLE OF A STAR**

It has been conservatively estimated that there are some 10,000 billion stars in the universe. It is difficult to know the exact age of a star (astronomers have identified stars as young as 25,000 years old and others are thought to be over 10 billion years old), but what astronomers do know is that there are many different kinds.

How each star is formed, and its mass, influences its type and longevity. A star is born in a nebula, which is a giant cloud of gas and dust. The larger the amount of matter that is in the nebula, the greater the mass of the star that is created. Inside these nebulae are dense areas of gas, which, due to their density, have a stronger gravitational pull than the rest of the nebula. Gradually, gravity drags the gas in the nebula together and it begins to spin and become increasingly hotter.

Once the temperature reaches 15,000,000°C, nuclear fusion occurs in the centre of the cloud and it begins to glow brightly. It stabilizes at this temperature, contracts slightly and becomes what is known as a main sequence star (an example of this is our own Sun). It can remain in this stage for millions or billions of years.

As it glows, hydrogen in the centre (through the nuclear fusion) becomes helium. Eventually the hydrogen supply in the core diminishes and the core of the star becomes unstable, contracting more. However, the outer parts of the star (which are still mainly hydrogen) expand and cool, and in doing so, the star starts to glow red.

It is at this stage that the star becomes a red giant. It is anticipated that it will take the Sun another 5 billion years to reach this stage. By then it will have grown large enough to engulf the three closest planets (Mercury, Venus and Earth) and glow 2,000 times brighter than it currently does.

Exactly how a star will react in the red giant phase depends on its mass. Throughout the red giant phase, the hydrogen in the outer parts carries on burning, and the centre gets hotter and hotter. On reaching 200,000,000°C, the helium atoms fuse forming carbon atoms. The remainder of the hydrogen explodes and forms a ring around the core called a planetary nebula.

With medium-sized stars, once the final helium atoms have fused into carbon atoms, the star starts to die. The gravitational pull leads to the last of the star's matter collapsing inwards and compacting to become extremely dense. A star like this is called a white dwarf. It will shine white-hot until the remaining energy (thermal energy trapped in its interior) has been exhausted after which it will no longer emit light. This can take in excess of several billion years. It is then termed a black dwarf (a cold, dark star, perhaps replete with diamonds) and remains in that stage forever.

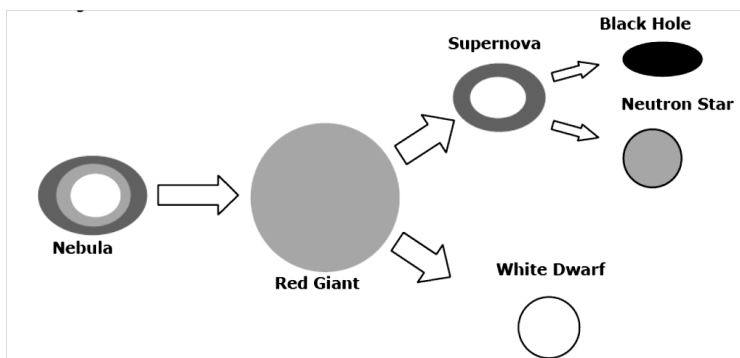

When the larger red giants (massive stars) collapse, which happens in an instant, so much planetary nebula is created that this gas and dust can be used as building material for planets in

developing solar systems. In addition, with massive stars, as the temperature increases, the carbon atoms get pulled together to form increasingly heavier elements like oxygen, nitrogen and finally iron. Once this happens, fusion ceases and the iron atoms begin absorbing energy. At some point in the future, this energy is released in a huge explosion called a supernova. A supernova can have a core temperature of up to 1,000,000,000°C and the explosion can light up the sky for weeks, outshining an entire galaxy. Astronomers believe that Earth is made up of elements formed from the inside of stars, in particular red giants that exploded as supernovas. These massive stars have an average life span of one million years.

After becoming a supernova, the remaining core of a massive star that is 1.5 to 4 times as massive as the Sun becomes a neutron star. It starts to spin and often emits radio waves. If these waves occur in pulses, the neutron star is referred to as a pulsar. When a massive star has eight or more times the mass of the Sun, it will remain massive after the supernova. It has no nuclear fusion supporting the core and becomes engulfed by its own gravity. This results in a black hole, which sucks in any matter or energy that passes close to it. The gravitational field of a black hole is powerful enough to prevent the escape of light and is so dense that it cannot be measured. The phrase 'black hole' originated from the physicist John Archibald Wheeler; before this, black holes were known as 'frozen stars.' Wheeler came up with this name two years before the proof of the existence of the first black hole, X-ray binary star Cygnus X-1, in 1971. Astronomers think that there may be a black hole at the centre of each galaxy.

The life cycle of a star is really that — the materials from an exploded star mix with the hydrogen of the universe. This mixture in turn will be the starting point of the next star. The Sun is a case in point, containing the debris from numerous other stars that exploded long before the Sun was born.

**Questions 1 – 6:** Different stages and types of stars are mentioned in Reading Passage 1. Choose ONE of the types or stages (A – H) from the box below which best matches the descriptions. NOTE: you may use any answer more than once.

A nebula	E black dwarf
B main sequence star	F supernova
C red giant	G neutron star
D white dwarf	H black hole

**Example:** hottest, brightest point of a star

**Answer:** F

1. the Sun \_\_\_\_\_
2. birthplace of a star \_\_\_\_\_
3. a dying star \_\_\_\_\_
4. sometimes has pulsating waves \_\_\_\_\_
5. its size is immeasurable \_\_\_\_\_
6. its supply of energy has run out \_\_\_\_\_

**Questions 7 – 13:** Complete the sentences using NO MORE THAN THREE WORDS for each answer. Write your boxes 7 – 13 on your Answer Sheet.

7. Hydrogen will turn to helium after \_\_\_\_\_ occurs.
8. The colour of the red giant is formed as the \_\_\_\_\_ becomes smaller and the outer areas cool.
9. At 200,000,000°C the star's helium atoms fuse into carbon atoms, and then the star \_\_\_\_\_.
10. Unlike small and medium-sized stars, large stars \_\_\_\_\_ quickly.
11. A black hole's \_\_\_\_\_ stops light from being emitted.
12. Astronomers knew about \_\_\_\_\_ before they were able to confirm their existence.
13. Planets and stars are likely to consist of \_\_\_\_\_ from exploded celestial bodies.

## READING PASSAGE 2

Questions 14 – 27 are based on Reading Passage 2.

**TOMATO RIPENING**

Tomatoes give off minute quantities of ethylene gas which is active in starting the natural ripening process. If left to nature; however, the tomatoes ripen in a random way. The trickled ethylene gas process of tomato ripening consists of exposing the tomatoes to a low concentration of ethylene gas under controlled temperature conditions in a special tomato-ripening room. This treatment initiates and controls the speed of the natural ripening and colouring process in the tomatoes.

Controlled ripening and colouring enables the grower to market tomatoes of more uniform colour and quality than is possible with green or field-ripened produce. Timing of harvesting and marketing may, within limits, also be regulated by the use of controlled ripening and colouring in order to achieve maximum returns and make the best use of labour and equipment.

**Ripening Conditions**

All fruit must be mature green at harvest for controlled ripening to be successfully carried out. Relative humidity does not appear to be of great importance in the tomato-ripening process. Little moisture loss from the tomatoes occurs during the ripening process due to the relatively impermeable nature of the tomato skin. Ripening time will depend on the ripening temperature range however, ripening temperatures above 24°C will result in poor colour development with yellow or orange fruit rather than red. The heating and cooling capacity should be such that the tomatoes can be brought to the recommended ripening temperature within 24 hours.

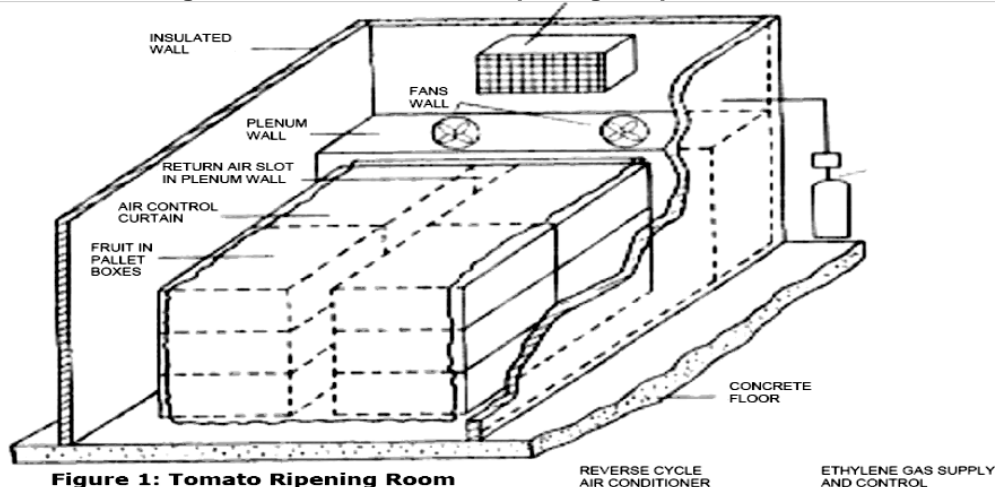

**Figure 1: Tomato Ripening Room**

REVERSE CYCLE  
AIR CONDITIONER

ETHYLENE GAS SUPPLY  
AND CONTROL

**General Arrangement**

A typical arrangement for a tomato ripening room is shown in Figure 1 with the essential components of the system identified.

**Room Size and Construction**

For efficiency and convenience in operation, on-farm tomato ripening rooms are usually sized to accommodate the normal daily tomato pick during the peak harvest time. The room capacity is generally in the range of two to ten tonnes of tomatoes; however, larger rooms may sometimes be installed. Since the average ripening time is three or four days, the provision of multiple rooms on the one farm is generally desirable.

**Air Circulation and Ventilation System**

Fan-forced air circulation is required for adequate and uniform temperature control and ethylene gas distribution in the ripening room. An air circulation rate of two room air volumes per minute is recommended for good results. This is equivalent to around 480 cubic metres of air per hour per tonne of tomatoes. At the recommended heating or cooling capacity of 0.6 to 1.2 kw per tonne of tomatoes, this gives an air temperature differential of 3.5 to 7°C across the heating or cooling system. These high air circulation rates are necessary to limit variations in temperature in different parts of the room to acceptable levels and to achieve an adequate rate of heating or cooling of the tomatoes. The ventilation system circulates the room air continuously, introducing

a small proportion of fresh air and exhausting a similar amount of air at the same time. This prevents a build up of ethylene gas in the room and also removes carbon dioxide produced by the fruit during respiration. If this carbon dioxide were allowed to build up to too high a level in the room atmosphere, it would interfere with the ripening process.

**Temperature Control System**

The temperature of tomatoes in the ripening room has a great influence on the ripening process. In fact, the product heat load usually represents around 80% of the total heat load. The remainder is due to heat transmission through the external walls of the room and the fresh air exchange rate. In some cases, both heating and cooling are required to maintain the room temperature within the required range. The time required for ripening can be reduced to some extent by increasing the temperature. Reverse cycle air-conditioners are successfully used for both heating and cooling in tomato-ripening rooms where humidity control does not appear to be of great importance.

**Supply and Control Systems**

With the trickled ethylene gas system, a low concentration of ethylene gas is maintained in the ripening room atmosphere by a continuous small, controlled flow of gas of about 10 parts per million (ppm). Ethylene gas is supplied as bottled gas under high pressure and it is released into the ripening room through a pressure regulator and metering system. The outlet gas pressure is adjusted by means of the gas pressure regulator and the gas flow rate is then adjusted by the fine needle valve. A normally closed solenoid valve in the ethylene gas supply line ensures that gas is not discharged into the room unless the fans and ventilation system in the ripening room are operating. The solenoid valve is electrically interlocked with the operation of the ventilation system fans and is also controlled by an air flow switch. A gas control thermostat is used to measure when gas should be supplied to the room. The temperature-sensing element of this thermostat is pushed into a tomato so that it senses the pulp temperature of the tomatoes in different parts of the room. Provided that the ethylene gas supply and control systems are correctly arranged, the ethylene gas concentration in the room will not exceed the low level which is sufficient for ripening but is far below the explosion hazard level. Under these conditions, tomato-ripening rooms installed on farms and used only for ripening fruit produced by the owner have been approved by certain Electricity Commissions as not constituting a hazardous location. *(Adapted from an article written by Brian Hesse for the 'Electrofarming Notebook' for The South East Queensland Electricity Board, October 1989.)*

**Questions 14 – 16:** Complete the table in the box below. Use NO MORE THAN THREE WORDS OR A NUMBER for each answer.

Requirements for successful use of the Ethylene Gas System for Tomato Ripening:

- 14. Tomatoes should be picked when they are \_\_\_\_\_.
- 15. Room temperature must be \_\_\_\_\_ °C.
- 16. Optimal ripening temperature for fruit must be achieved \_\_\_\_\_.

**Questions 17 – 20:** Complete the flow chart below using information from the text. Use NO MORE THAN THREE WORDS for each answer. Write your answers in boxes 17 – 20 on your Answer Sheet.

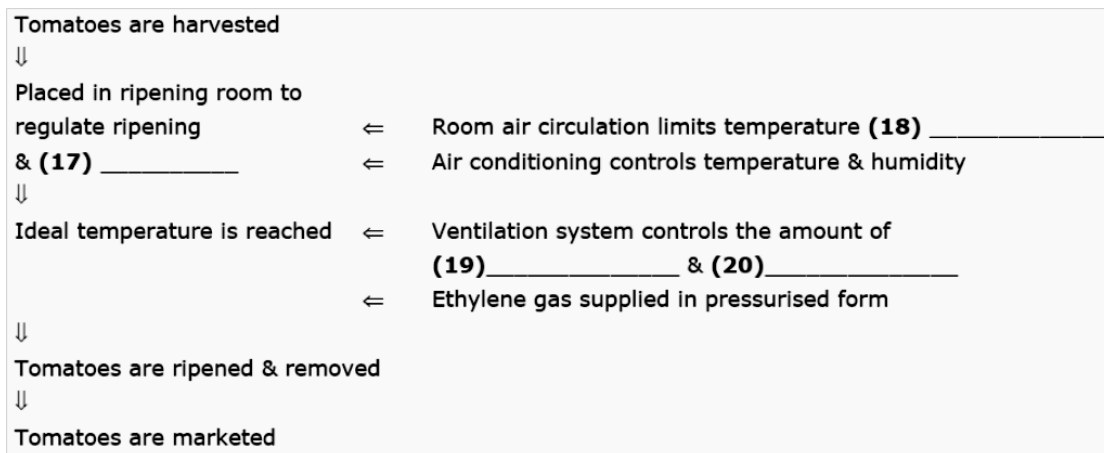

**Questions 21 — 27:** Below is a list of assumptions. Using the information given in the passage, choose:

TRUE if it is a reasonable assumption  
 FALSE if it is NOT a reasonable assumption  
 NOT GIVEN if it is not possible to make the assumption from the information in the text.

Write your answers in boxes 21 – 27 on your Answer Sheet.

*Example:* Ethylene gas systems improve the grower's chance of selling the tomatoes.

Answer TRUE

21. Carbon dioxide is not beneficial to the ripening process.
22. The outside air temperature determines the amount of extra heating needed in the ripening room.
23. Increased temperature can speed up the maturing process.
24. For successful tomato ripening, humidity levels need to be carefully monitored.
25. The solenoid valve has to be checked at regular intervals.
26. A build up of ethylene gas may result in an explosion.
27. Setting up ethylene gas ripening rooms is not always safe.

READING PASSAGE 3

Questions 28 – 40 are based on Reading Passage 3.

## ECO-TOURISM

If you still believe the once-commonly held misconception that tourism is only an indulgence for the wealthy, you are out of step with the times! The tourism market is accessible to, and indeed marketed toward, many different sections of the community. Adventurers, fitness freaks, nature-lovers and business people all contribute to a rapidly expanding sector of the global economy.

### Section A

This billion-dollar industry, whilst affected slightly by the unforeseen events of 11 September 2001, has experienced significant growth since the late 1980s. The subsequent economic benefits for governments are well-documented as tourism boosts foreign investment and foreign exchange. Large-scale resorts and civil infrastructure were often the only response to successful marketing and increased tourist demand. It is not surprising then that the direct impact on the environment and regional or indigenous populations became a contentious issue. Governments and big business became the target of environmentalists and activists who argued that mass tourism was not (and is not) sustainable. As hordes of tourists descended on often overcrowded beaches and overused parklands, this became apparent. Eco-tourism was born.

### Section B

The broad concept of eco-tourism as a nature-based, culturally sensitive form of tourism was taken up enthusiastically because there appeared to be few losers. Governments were given a convenient escape route as eco-tourism appeased the environmentalists and local communities, but still provided income. Environmentalists saw eco-tourism as an alternative to mass tourism and its resource-exploiting ways. Local communities envisaged receiving at least a percentage of the tourist dollars, creating job opportunities and giving them control over the impact on their own communities. It seemed that the benefits of mass tourism were going to be expanded in the new world of eco-tourism to include cultural, social and environmental elements.

### Section C

As evidence of the benefits of eco-tourism unfolded, the practice has spread. So much so that the United Nations nominated 2002 as the International Year of Eco-tourism. Perhaps inevitably, the meaning of ecotourism became less clear as it enveloped the globe. It could be argued that the form of eco-tourism adopted in some cases was found wanting in certain aspects and the need for agreement on a tighter definition resulted. The eco-tourist is one who does not wish to contribute to the negative impact of large-scale tourism. He/she generally travels in small groups to low-key developments and attempts to "tread lightly" on the earth. These smaller-scale developments are

environmentally responsible with a view to sustainability in all of the resources used. Their landscaping often relies on the use of native flora and they incorporate recycling methods and energy-efficient practices. Within the eco-tourist's holiday experience will be an element of education about the local environment. The emphasis is on conservation and the part that humans play in keeping ecosystems functioning. If the area is of cultural or social importance, this too is highlighted. The eco-tourist doesn't condone the exploitation of the indigenous or local community. Far from it, they insist that the host culture is acknowledged and respected. The repatriation of funds to external sources is frowned upon. Wherever possible, the benefits of an eco-tourist's holiday should be shared with the regional community — the hosts.

#### Section D

All of these elements promote minimal impact on human resources as well as on physical, cultural and environmental ones. They support conservation through education and experience. Despite the best of intentions, as popularity of eco-tourism spreads there is concern that the eco-tourist will have a more adverse effect on the environment. Critics argue that unethical tour operators wanting to take advantage of the trendy eco-tourism market print brochures that espouse the ethics of eco-tourism and show familiar emblems of green frogs and crocodiles to promote themselves but do little else. If such operators are not held accountable, the industry will not survive. Open and honest eco-tourism marketing as well as world-recognised accreditation must be endorsed and implemented. The sheer volume of tourists wanting to visit unique, unspoiled environments is also a cause for concern. Evidence of the need to restrict the number of visitors to sensitive areas exists in many eco-tourist attractions already. Hikers and bush walkers in Mount Kenya National Park have caused damage by straying from set trails and leaving food scraps behind. The number of Orca whales visiting Canada has declined in recent migratory seasons, as the restrictions placed on whale-watching boats and organisers are thought to be inadequate.

#### Section E

Eco-tourism does not guarantee sustainable tourism and it should not be viewed as a complete cure for the problems that have beset tourism. Until all stakeholders agree to a definition of eco-tourism, insist that ecotourism operators abide by a strict code of ethics and carefully monitor the impact of eco-tourism (and all tourism), fragile ecosystems will continue to be besieged by tourists. There must be an educational program to promote ecologically-sustainable tourism across the board, so that the underlying principle in ALL forms of tourism is the management of resources. Eco-tourism can bring wealth to areas where there is nothing else but natural attractions. The reasons for visiting The Galapagos Islands in Ecuador can only be explained by an interest in nature itself. The subsequent tourist dollars, if re-injected into the community, can mean the survival of such habitats. Licenses and entry fees to some sites have, in many cases, replaced government funding as their source of income. Countries as diverse as Australia, New Zealand, Costa Rica and Kenya are developing strategies to identify and cope with the constraints that inevitably come with a long-term vision of sustainable tourism. Eco-tourism has played an important role in developing an awareness for sustainable tourism practices but governments, tourist agencies and operators must be willing to join forces with eco-tourists to ensure that natural attractions are protected from their own popularity.





Achieve IELTS Reading 1**Trans Fatty Acids**

*A recent editorial in the British Medical Journal (BMJ), written by researchers from the University of Oxford has called for food label to list trans fats as well as cholesterol and saturated fat.*

Trans fats (or trans fatty acids) are a type of unsaturated fatty acid. They occur naturally in small amounts in food produced from ruminant animals\* e.g. milk, beef and ham. However most of the trans fatty acids in the diet are produced during the partial hydrogenation (hardening) of vegetable oils into semi solid fats. They are therefore found in hard margarines, partially hydrogenated cooking oils, and in some bakery products, fried foods, and other processed foods that are made using these.

Trans fatty acids have an adverse effect on certain chemicals, known as lipids, which are found in the blood and have been shown to increase the risk of heart disease. They also increase LDL cholesterol (the bad cholesterol) and decrease HDL-cholesterol (the good cholesterol). They may also have adverse effects on cardiovascular disease risk that are independent of an effect on blood lipids. (Mozaffarian et al. 2006).

In a recent review of prospective studies investigating the effects of trans fatty acids, a 2% increase in energy intake from trans fatty acids was associated with a 23% increase in the incidence of heart disease. The authors also reported that the adverse effects of trans fatty acids were observed even at very low intakes (3% of total daily energy intake, or about 2-7g per day) (Mozaffarian et al. 2006).

However in this recent review it is only trans fatty acids produced during the hardening of vegetable oils that are found to be harmful to health. The public health implications of consuming trans fatty acids from ruminant products are considered to be relatively limited.

Over the last decade, population intakes of trans fatty acids in the UK fell and are now, on average, well below the recommended 2% of total energy set by the Department of Health in 1991, at 1.2% of energy (Henderson et al. 2003). This is not to say that intakes of trans fatty acids are not still a problem, and dietary advice states that those individuals who are in the top end of the distribution of intake should still make efforts to reduce their intakes.

Currently, trans fatty acids in food are labelled in the USA, but not in the UK and Europe. The UK Food Standards Agency (FSA) is in favour of the revision of the European directive that governs the content and format of food labels so that trans fatty acids are labelled. This should enable consumers to make better food choices with regard to heart health (Clarke & Lewington 2006).

Recognising the adverse health effects of trans fatty acids, many food manufacturers and retailers have been systematically removing them from their products in recent years. For example, they have been absent for some time from major brands of margarine and other fat spreads, which are now manufactured using a different technique. Also, many companies now have guidelines in place that are resulting in formulation and reduction or elimination of trans fatty acids in products where they have in the past been found, such as snack products, fried products and baked goods. Consequently, the vast majority of savoury biscuits and crisps produced in the UK do not contain partially hydrogenated oils. Similarly, changes are being made to the way bakery products are manufactured. For example, a leading European manufacturer of

major brands of biscuits, cakes and snacks has recently announced that these are now made without partially hydrogenated vegetable oils, a transition that began in 2004. Alongside these changes, the manufacturer has also reported a cut in the amount of saturates. It is clear that a major technical challenge in achieving such changes is to avoid simply exchanging trans fatty acids for saturated fatty acids, which also have damaging health effects.

Foods that are labelled as containing partially-hydrogenated oils or fats are a source of trans fatty acids (sometimes partially-hydrogenated fats are just labelled as 'hydrogenated' fats). These foods include hard margarines, some fried products and some manufactured bakery products e.g. biscuits, pastries and cakes.

It is important to note that intake may have changed in the light of reformulation of foods that has taken place over the past six years in the UK, as referred to earlier. Furthermore, the average intake of trans fatty acids is lower in the UK than in the USA (where legislation has now been introduced). However, this does not mean there is room for complacency, as the intake in some sectors of the population is known to be higher than recommended.

\*animals that mainly eat grass

*Trans Fatty Acids taken from BMJ, 2006, volume 333*

#### Questions 1-7

Do the following statements agree with the information given in Reading Passage 1

TRUE if the statement agrees with the information  
 FALSE if the statement contradicts the information  
 NOT GIVEN if there is no information on this

1. Trans fatty acids are found in all types of meat.
2. Health problems can be caused by the consumption of small amounts of trans fatty acids
3. Experts consider that the trans fatty acids contained in animal products are unlikely to be a serious health risk.
4. In Britain, the intake of trans fatty acids is continuing to decline.
5. The amount of saturated fats in processed meats is being reduced by some major producers.
6. It is proving difficult to find a safe substitute for trans fatty acids
7. Some people are still consuming larger quantities of trans fatty acids than the experts consider safe.

#### Questions 8-13

Complete the sentences below. Choose NO MORE THAN THREE WORDS from the passage for each answer.

8. Scientists at Oxford University propose that information about trans fatty acid should be included on .....
9. In food manufacture, the majority of trans fatty acid are created when ..... are solidified.
10. The likelihood of a person developing .....is increased by trans fatty acid consumption.
11. In the UK, the ..... established a limit for the daily consumption of trans fatty acids.
12. Partially hydrogenated oils are no longer found in most UK manufactured salty .....
13. Consumption of trans fatty acids in.....is now higher than in the UK.

## PASSAGE 2

**BIO FUELS**

*Are biofuels really the greenhouse-busting answer to our energy problems? It's not that simple, say Fred Pierce.*

- A. Soon, we're told, corn crops will be as valuable as oil. This is because corn and a few other crops are being promoted as the biofuels of the future. Biofuel is an umbrella term used to describe all fuels derived from organic matter. The two most common biofuels are bioethanol which is a substitute for gasoline and biodiesel. Not only have soaring oil prices made biofuels economically viable for the first time in years but they could also help countries reduce their dependency on fossil fuel imports. However, the real plus point in the minds of many is their eco friendly image.
- B. Supporters claim they will cut our net greenhouse gas inputs dramatically because the crops soak up carbon dioxide from the atmosphere as they grow. Given this fact it's no surprise that politicians and environmentalists the world over are backing the idea, hoping we will soon be using this green alternative to power their cars, buses and trains. Other scientists, however, have begun to question the environmental and social arguments for biofuels. Far from solving our problem, they believe biofuels will destroy rainforests, suck water reserves dry, kill off species and raise food prices. Worst of all they claim that many biofuels will hardly slow global warming at all if the technology behind them does not improve. Biofuel supporters counter that it's still early days, and we should give this technology the time and investment to deliver on its promise. So, who's right?
- C. The controversy may be brand new, but the biofuels themselves are an old idea. The Model T Ford, first produced in 1908, was designed to run on ethanol, and Rudolf Diesel who invented the diesel engine in 1892, ran his demonstration model on peanut oil. Biofuels fell out of favour as petroleum-based fuel appeared and became cheaper to produce. But, after the oil crisis of the early 1970s, some countries returned to biofuels. For example, Brazil has been producing large quantities of ethanol from sugarcane for over 30 years. Brazilian law now requires that 20 per cent of fuel be blended with bioethanol which all gasoline-powered cars can tolerate. Over 15 per cent of Brazil's cars can even run on pure bioethanol.
- D. According to a recent study by the World Watch Institute, for Brazil to produce ten per cent of its entire fuel consumption, requires just three per cent of its agricultural land, so it's not surprising that other places want to emulate Brazil's approach. The problem is that in most other countries the numbers don't add up. The same study estimated that to meet that ten per cent target, the US would require 30 per cent of its agricultural land, and Europe a staggering 72 per cent. It's no secret why things stack up so differently. Not only do Brazilians drive far less than Europeans and Americans, their fertile land and favourable climate mean their crop yield are higher and their population density is lower.
- E. Several research groups have tried to compare fossil fuel emissions with those of corn bioethanol at every stage of production from seed sowing to fuel production. The studies have been beset by scientific uncertainties, such as how much of the greenhouse gas nitrous oxide is produced by the nitrogen fertiliser used in growing corn. Opinions are divided as to what should and should not be included in the calculations, which means the results vary widely, but a study by David Pimental at Cornell University in New York concluded that corn ethanol creates more greenhouse gases than burning fossil fuel.
- F. Another reason a growing number of people oppose biofuels is that growing corn for ethanol uses up land that is currently supplying food to the world. According to Lester Brown, veteran commentator and activist on food politics, the corn required to fill a 4x4 tank with bioethanol just once could feed one person for a year. He predicts that a boom in bioethanol

would lead to a competition between 800 million people in the world who own automobiles and three billion people who live on less than \$2 a day, many of whom are already spending over half their income on food.

- G. So are we already mistaken to think that bioethanol could usher in an era of greener energy? The way things are developing, it certainly looks that way, but it needn't be so. Scientists want to perfect a way to make bio-fuels from non food crops and waste biomass saving the corn and other food crops for food use and to do it without wrecking natural ecosystems. Already researchers are discovering ways to convert cellulose-rich organic matter into ethanol. Cellulose is the main structural component of all green plants. Its molecules comprise chains of sugars strong enough to make plant cell walls. If you could break down these molecules to release the sugars they contain, you could ferment them until ethanol is created. Developing such a process could open the door to many non-food materials such as switchgrass - a wild grass that lives on the eastern states and Midwest of the US – straw, crop residues like stalks and hardwood chips. Its supporters say these cellulose materials could deliver twice as much ethanol per hectare as corn, and do it using land that is today neither economically productive nor environmentally precious. Some even think municipal waste such as paper, cardboard and waste food could also be used. If the numbers add up this could be the development that may yet deliver us from our dependence on oil without costing us the Earth in the process.

#### Questions 14 - 19

Reading Passage 2 has seven paragraphs, A - G. Which paragraph contains the following information.

14. reasons for the success of bioethanol production in the region
15. an individual's prediction of the consequences of increasing production of corn ethanol
16. a reference to why biofuels might help to slow down global warming
17. a definition of biofuel
18. a reference to research that found one type of bioethanol to be less eco-friendly than oil
19. examples of how ethanol was used as a fuel before petroleum

#### Questions 20 - 25

Complete the summary below. Choose NO MORE THAN TWO WORDS from the passage for each answer.

#### Using Non-Fuel Crops to Make Biofuels

A major constituent of green plants is cellulose. The 20.....of cellulose are made up of sugars. These form the 21.....of plants. Ethanol could be produced by extracting the sugars and allowing them to 22..... One common North American plant that could be used in this method is 23..... Some scientists believe that this would be a more productive source of ethanol than 24..... Additionally, the source plant materials could be grown in ground which is not currently being used for agriculture and is not 25.....valuable.

#### Question 26

Choose the correct letter A, B, C or D

What conclusion does the writer of the text come to?

- A. Bioethanol made from sugarcane will be the cheapest fuel worldwide
- B. The US could become self-sufficient in biofuel made from corn.
- C. A biofuel may be made in time which does not damage the environment.
- D. Scientists agree that some form of bioethanol is the future for fuel.

#### Passage 3

### **A Comparative study of Innovation Practices in Business**

#### ***Companies want to be innovative, but what does innovation mean?***

Results of interviews with corporate executives and senior innovation officers in four of the largest publically-traded companies and one government agency in the Chicago-area, provide some insight into how businesses approach innovation.

The dictionary defines innovation as "the introduction of something new". Regardless of the type of innovation - whether it be product, process or service - it results in significant change. This

change could be as simple as changing the way we do something routine: a breakthrough which provides a substantial benefit to the customer, or one that dramatically increases the revenue or profitability of the company

Participants interested in breakthrough innovation believe 'if innovation doesn't deliver bottom-line results, it is just creativity'. Indeed, the very definition of innovation for Afuah (2003) is 'invention plus commercialization.' The relationship of innovation to financial performance was well demonstrated by Kim and Mauborgne (1997). In manufacturing environments, they found that while 86% of product launches involved some small improvements to existing models - that is incremental changes, they accounted for only 62% of total revenues and 39% of total profits, The remaining 14% of launches, the real breakthrough innovations - generated 38% of total revenues and a huge 61 % of total profits.

Innovation may offer one significant way that companies can gain advantage. Utterback's (1994) concept of 'dominant design' provides insight into how an innovation can create a temporary monopoly situation that will weaken competitive forces however, when an innovative product or service is launched, rivals typically begin to copy it (once patents run out). Hence it is necessary for the company to continuously seek further ways to innovate.

Every innovation process has its strengths and weaknesses, but it seems that when a company sets up a systematised innovation process it communicates the importance of innovation to the entire organisation. In these companies, more resources are devoted to development. The best companies have learned to systematize the process (Hargadorn & Sutton 2000)

The primary disadvantage to having a structured innovation process is speed to market - the more structure, the longer the lead time is from idea to product. The only company that described its process as 'quick' did not have such a process. Employees were empowered to solve problems and create new products for the customer by responding to demand. While this benefits customers, the company stated it lacked systems to share learning with other segments of the organization. A potential disadvantage of this approach, according to Utterback, is that evolutionary change can be missed when companies are too focussed on pleasing customers.

The most challenging aspect of any innovation is determining marketability. No company said it lacked creative ideas or creative people, but many ideas require significant resources to test, develop and launch. Millions of dollars are at stake, so an element of risk-taking is required.

Taking risks is generally defined as being able to drive new ideas forward in the face of adversity. Publically traded companies have a major dilemma. To guarantee a leadership position they have to stay on the leading edge of innovation. This requires a long-term approach and a high tolerance for risk. Investors especially in a down economy, want short term results. As investors' tolerance for risk decreases, so does the company's ability to take the significant financial risk necessary to create breakthrough changes; however, most recognize that investing in innovation is the 'right thing to do'.

One company actively pursues a rather unusual strategy of acquiring innovation by purchasing other smaller companies or partnering with specialized companies. This enables the acquiring company to bring a product to market more quickly and gives the smaller company access to funds it might not otherwise have.

How can a company involve all its employees in the innovation process? It may be as simple as requesting new ideas. A brainstorming session during a staff meeting need only take 30 minutes. Another system is to use existing suggestions box processes, Involving employees in idea-generation can reap some large benefits at a very low cost. Only modest monetary rewards are necessary for successful innovation ideas, especially since many companies have found that employees place high value on recognition.

In most organisations, teams are extensively used to evaluate ideas, but rarely to generate them. Companies need to learn how to construct teams for the purpose of innovation. A team member should be selected on their tendency to be more creative or more risk taking. This could markedly increase innovation output. According to Hargadorn and Sutton, using teams to capture and share ideas is one method of keeping ideas alive - a key step in the innovation process. Good ideas need to be nurtured by teams and incorporated into the information and communication system of the company.

In conclusion, innovation can be difficult to structure. It is the authors' perception that even the most innovative companies in the sample under invest in market research during the concept refining phase. Risk could be reduced considerably by adoption of this strategy but, of course, it could not be culminated.

Most of the problems cited by participants were due to a low tolerance for risk - by employees (what they would or would not say), and by committees, (being afraid to invest money without knowing the return on investment). Raising the risk tolerance would reduce the amount of analysis required to bring a new idea to market, thus shortening the cycle time of new product/service development. According to psychologists Kahn and Hirshorn, people come alive when they feel safe. It is threat and anxiety that inhibit them. It would follow that in order for people in organisations to take risks, lack of success must be tolerated. The organisations that manage risk most effectively transform those risks into challenges and opportunities.

### Questions 27 - 33

Look at the following theories (Questions 27 – 33) and the list of experts below.

Match the theories with the correct expert A-E. You may use any letter more than once.

27. A business cannot rely on the success of one good innovation.
28. A group approach is an effective way of generating innovation,
29. Employees are more creative in a culture that accepts failure.
30. Radical innovations will provide greater income than minor changes.
31. Businesses with a structured approach to innovation are more likely to succeed.
32. Innovation consists of a new idea combined with business potential.
33. A business that concentrates on responding to clients needs may overlook the need for wider development.

### List of experts

- A. Afuah
- B. Kim and Mauborgne
- C. Utterback
- D. Hargadorn and Sutton
- E. Kahn and Hirshorn

### Questions 34 - 40

Complete each sentence with the correct ending A - I below.

34. Unfortunately the development of an organised innovation process .....
35. One of the most difficult issues in innovation .....
36. A company wanting to maintain a leading position in business.....
37. A different approach to achieving innovation .....
38. Getting staff to come up with new Ideas.....
39. A recommendation for companies already committed to innovation.....
40. Problem experienced by companies participating in the study.....
  - A. can be to develop a sympathetic manufacturing environment.
  - B. must put time and money into innovation.
  - C. can be a very cost-effective way of achieving innovation.
  - D. may require a more sophisticated communication system.
  - E. may give rise to a lengthy period between initial concept and launch
  - F. could be attributed to an unwillingness to accept risk
  - G. can be to work out the saleability of a future product
  - H. would be to put more money into the analysis of customer demand.
  - I. might involve collaboration with another company with particular expertise.

## **Unlikely Boomtowns: The World's Hottest Cities**

Megacities like London, New York and Tokyo loom large in our imaginations. They are still associated with fortune, fame and the future. They can dominate national economies and politics. The last fifty years has been their era, as the number of cities with more than ten million people grew from two to twenty. But with all respect to the science fiction novelists who have envisioned a future of urban giants, their day is over. The typical growth rate of the population within a megacity has slowed from more than eight percent in the 1980s to less than half that over the last five years, and numbers are expected to be static in the next quarter century. Instead, the coming years will belong to a smaller, more humbler relation - the Second City.

Within a few years, more people will live in cities than in the countryside for the first time in human history. But increasingly, the urban core itself is downsizing. Already, half the city dwellers in the world live in metropolises with fewer than half-a-million residents. Second Cities - from exurbs, residential areas outside the suburbs of a town, to regional centres are booming. Between 2000 and 2015, the world's smallest cities (with under 500,000 people) will grow by 23 per cent, while the next smallest (One million to five million people) will grow by 27 per cent. This trend is the result of dramatic shifts including the global real estate bubble; increasing international migration; cheaper transport; new technologies, and the fact that the baby-boom generation is reaching retirement age.

The emergence of Second Cities has flowed naturally (if unexpectedly) from the earlier success of the megacities. In the 1990s, megacities boomed as global markets did. This was particularly true in areas with high tech or 'knowledge based' industries like finance. Bonuses got bigger, bankers got richer and real estate prices in the world's most sought-after cities soared. The result has been the creation of what demographer William Frey of the Washington based Brookings Institute calls 'gated regions' in which both the city and many of the surrounding suburbs have become unaffordable for all but the very wealthy. Economically, after a city reaches a certain size its productivity starts to fall,' notes Mario Pezzini, head of the regional competitiveness division of the OECD. He puts the tipping point at about six million people, after which costs, travel times and the occasional chaos create in which the centre of the city may be a great place, but only for the rich, and the outlying areas become harder to live and work in.

One reaction to this phenomenon is further sprawl - high prices in the urban core and traditional suburbs drive people to distant exurbs with extreme commutes into big cities. As Frey notes, in the major US metropolitan areas, average commuting times have doubled over the last fifteen years.

Why does one town become a booming Second City, while another fails? The answer hinges on whether a community has the wherewithal to exploit the forces pushing people and businesses out of the megacities. One key is excellent transport links, especially to the biggest commercial centres. Though barely a decade old, Goyang is South Korea's fastest-growing city in part because it is 30 minutes by subway from Seoul.

Another growth driver for Second Cities is the decentralisation of work, driven in large part by new technologies. While more financial deals are done now in big capitals like New York and London than ever before, it is also clear that plenty of booming service industries are leaving for 'Rising Urban stars' like Dubai, Montpellier and Cape Town. These places have not only improved their Internet backbones but often have technical institutes and universities that turn out the kinds of talent that populate growth industries.

Consider Montpellier, France, a case study in urban decentralisation. Until the 1980s, it was like a big Mediterranean village. Once the high speed train lines were built, Parisians began pouring in for weekend breaks. Some bought houses, creating a critical mass of middle-class professionals who began taking advantage of flexible working systems to do three days in Paris, and two down

South, where things seemed less pressured. Soon big companies began looking at the area, a number of medical technology and electronic firms came to town, and IBM put more investment into service businesses there. To cater to the incoming professionals, the city began building amenities: an opera house, a tram line to discourage cars in the city centre. The result, says French urban-planning expert Nacima Baron, is that the city is now full of cosmopolitan business people. It's a new society'.

All this means that Second Cities won't stay small. Indeed countries are actively promoting their growth. Italy, for example, is trying to create tourist hubs of towns close to each other with distinctive buildings and offering different yet complementary cultural activities. Devolution of policy making power is leaving many lesser cities more free than ever to shape their destinies. To them all: This is your era. Don't blow it.

**Questions 1-3** Choose three letters A-G. Which THREE of the following statements are true of megacities according to the text

- A. They tend to lead the way in terms of fashion.
- B. Their population has ceased to expand.
- C. They reached their peak in the second half of the twentieth century.
- D. 50 per cent of the world's inhabitants now live in them,
- E. They grew rich on the profits from manufacturing industry.
- F. Their success begins to work against them at a certain stage.
- G. It is no longer automatically advantageous to base a company there

**Questions 4 - 6** Choose three letters A-G

The list below gives some possible reasons why small towns can turn into successful Second Cities. Which THREE of these reasons are mentioned by the writer of the text

- A. the existence of support services for foreign workers
- B. the provision of cheap housing for older people
- C. the creation of efficient access routes
- D. the ability to attract financial companies
- E. the expertise to keep up with electronic development
- F. the maintenance of a special local atmosphere
- G. the willingness to imitate international style architecture

**Questions 7 - 13** Complete the summary by using the list A-R below.

#### Urban Decentralisation

It is becoming increasingly obvious that large numbers of 7.....are giving up their expensive premises in the megacities and relocating to smaller cities like Montpellier. One of the attractions of Montpellier is the presence of a good 8..... that can provide them with the necessary skilled workforce.

Another important factor for Montpellier was the arrival of visitors from the 9.....

The introduction of the 10.....meant that increasing numbers were able to come for short stays. Of these, a significant proportion decided to get a base in the city. The city council soon realised that they needed to provide appropriate 11.....for their new inhabitants. In fact, the 12.....among them liked the more relaxed lifestyle so much that they took advantage of any 13.....arrangements offered by their firms to spend more of the week in Montpellier.

- A. urban centres
- B. finance companies
- C. flexible
- D. tram line
- E. cosmopolitan
- F. service industries
- G. capital
- H. high speed train
- I. infrastructure
- J. unskilled workers
- K. jobs
- L. medical technology
- M. professionals
- N. European Union
- O. amenities
- P. middle age
- Q. overtime
- R. university

**PASSAGE 2**



**Questions 14 - 20** Reading passage 2 has seven paragraphs, A-G. Choose the correct heading for each paragraph A-G from the list below

**List of Headings**

i.	The influence of the seasons on productivity
ii.	A natural way to anger management
iii.	Natural building materials promote health
iv.	learning from experience in another field
v.	Stimulating the brain through internal design features
vi.	Current effects on the species of ancient experiences
vii.	Uniformity is not the answer
viii.	The negative effects of restricted spaces
ix.	Improving occupational performance
x.	The modern continuation of ancient customs

14. Paragraph A

15. Paragraph B

16. Paragraph C

17. Paragraph D

18. Paragraph E

19. Paragraph F

20. Paragraph G

**Psychosocial Value of Space**

- A. What would a building space look and feel like if it were designed to promote psychological and social well-being? How would it affect the senses, the emotions and the mind? How would it affect behavioural patterns? For insights, it is useful to look not at buildings but at zoos. Zoo design has gone through a radical transformation in the past several decades. Cages have been replaced by natural habitats and geographic clustering of animals. In some places, the animals are free ranging and the visitors are enclosed in buses or trains moving through the habitat. Animals now exist in mixed species exhibits more like their natural landscapes. And, as in nature, the animals have much greater control over their behaviour. They can be on view if they want, or out of sight. They forage, play, rest, mate and act like normal animals.
- B. What brought about this transformation in philosophy and design? A key factor was concern over the animals' psychological and social well-being. Zoos could keep animals alive but they couldn't make them flourish. Caged animals often exhibit neurotic behaviours – pacing, repetitive motions, aggression and withdrawal. In one more example, an animal psychologist was hired by the Central Park Zoo to study a polar bear that spent the day swimming in endless figure of eights in its small pool. This was not normal polar bear behaviour and the zoo was concerned about it. After several days of observation, the animal psychologist offered a diagnosis. The bear was bored. To compensate for this unfortunate situation, the zoo added amenities and toys to bear's enclosure to encourage exploration and play.
- C. Are there lessons that we can apply in building design? Some experts believe so. For example biologist Stephen Boyden (1971) defines the optimum healthy environment as 'the conditions which tend, promote or permit an animal optimal psychological, mental and social performance in its natural or "evolutionary" environment. Because humans evolved in a natural landscape, it is reasonable to turn to the natural environment for clues about performance patterns that may be applicable to building design. Drawing on habitat selection theory ecologist Gordon Orians argues that humans are psychologically adapted to and prefer landscape features that characterised the African plains or savannah, the presumed site of human evolution. Although humans now live in many different habitats, Orians argues that our species long history as mobile hunters or gatherers on the African

savannahs should have left its mark on our psyche. If the 'savannah hypothesis' is true we would expect to find that humans intrinsically like and find pleasurable environments that contain the key features of the savannah most likely to have aided our ancestors' survival and well being.

- D. Although Boyden distinguishes between survival and well being needs, they often overlap. For example people clearly need food for survival and health. However, food often serves as the basis for bonding and relationship development. The ritual of sitting around a fire on the savannah or in a cave telling stories of the day's events and planning for tomorrow may be an ancient carry over from Homo sapiens' hunting and gathering days. According to anthropologist Melvin Konner, the sense of safety and intimacy associated with the campfire may have been a factor in the evolution of intellectual progression as well as social bonds. Today's hearth is the family kitchen at home, and the community places, such as cafes and coffee bars, where people increasingly congregate to eat, talk, read and work.
- E. A growing body of research shows that building environments that connect people to nature are more supportive of human emotional well being and cognitive performance than environments lacking these features. For instance, research by Roger Ulrich consistently shows that passive viewing of nature through windows promotes positive moods. Similarly, research by Rachel Kaplan found that workers with window views of trees had a more positive outlook on life than those doing similar work but whose windows looked out onto a parking lot. Connection to nature also provides mini mental breaks that may aid the ability to concentrate, according to a research by Stephen Kaplan. Terry Hartig and colleagues report similar results in a field experiment. People in their study who went for a walk in a predominantly natural setting achieved better on several office tasks requiring concentration than those who walked in a predominantly built setting or who quietly read a magazine indoors.
- F. Studies of outdoor landscapes are providing evidence that the effects of nature on human well being and health extend beyond emotional and cognitive functioning to social behaviour and crime reduction. For instance, Francis Kuo found that outdoor nature buffers aggression in urban high-rise settings and enhances ability to deal with demanding circumstances. He also reported that planting trees in urban areas increases sociability by providing comfortable places for residents to talk with one another and develop friendships that promote mutual support.
- G. A natural perspective also contributes important insights into comfort maintenance. Because people differ from one another in many ways (genetic, cultures, lifestyles) their ambient preferences vary. Furthermore, a given person varies over time depending upon his or her state of health, activities, clothing levels and so forth. For most of human history, people have actively managed their surroundings as well as their behaviours to achieve comfort. Yet buildings continue to be designed with a 'one size fits all' approach. Very few buildings or workstations enable occupants to control lighting, temperature, ventilation rates or noise conditions. Although the technology is largely available to do this, the personal comfort systems have not sold well in the market place, even though research by Walter Kroner and colleagues at Rensselaer Polytechnic Institute shows that personal control leads to significant increases in comfort and morale.

Look at the following people (Questions 21 – 26) and the list of theories below. Match the person with the correct theory A-I. You may use any letter more than once.

21. Gordon Orian
22. Melvin Konner
23. Roger Ulrich
24. Stephan Kaplan
25. Francis Kuo
26. Walter Kroner

**List of theories**

- A. Creating a green area can stimulate a sense of community.
- B. People need adequate living space in order to be healthy
- C. Natural landscape can both relax and sharpen the mind
- D. Cooking together is an important element in human bonding,
- E. People feel more ease if they can adjust their environment.
- F. Looking at a green environment improves people's spirits.
- G. Physical exercise improves creative thinking at work.
- H. Man's brain developed partly through regular association with peers
- I. We are drawn to places similar to the area where our species originated.

**Passage 3**

**Ditching that Sainly Image**

Charities, it is still widely believed, are separate from government, staffed entirely by volunteers and spend every penny donated on the cause they support. Noble stuff, but in most cases entirely wrong. Yet these misapprehensions underpin much of the trust and goodwill behind giving. And there is concern that such outdated perceptions could blow up in charities' faces as people begin to discover what the voluntary sector is really about.

High profile international programmes of awareness raising activities such as Make Poverty History, have dragged the voluntary sector into the spotlight and shown charity workers to be as much business entrepreneurs as they are angels of mercy. But with the spotlight comes scrutiny and unless charities present compelling cases for political campaigning, six-figure salaries and paying the expenses of celebrities who go on demanding trips to refugee camps for nothing, they may get bitten. If people become more sceptical about how charities use their donations, they will be less inclined to give money,' says Nick Aldridge, director of strategy at the Association of Chief Executives of Voluntary organisations(ACEVO)

A wide range of initiatives have been undertaken to secure long term trust in the sector by explaining what charities do and publishing the figures. But it's still difficult to give donors a complete picture because, unlike profit-driven businesses, charities can't measure achievement purely by the bottom line.

The report Funding Success suggests this might explain some of the communication difficulties charities face. Nevertheless, it suggests there are sound reasons for trying. Many funders, it claims regard high overheads on, for example premises, publicity and so on, that are properly accounted for as a sign of an efficiently run organisation, rather than a waste of resources. Detailed reporting can be an important element in efforts to increase transparency. Better information might also unlock more money by highlighting social problems, and explaining what might be done to address them.

Some charities are also taking steps in this direction. The Royal National Institute For The Deaf (RNID) introduced annual Impact reporting to tell people about the effects of its work in a broader sense than an annual report would usually allow.

Each impact report looks back at what has been achieved over the previous 12 months and also states the charity's aims for the year ahead. Brian Lamb, director of communications at RNID, says the sector has been complacent about transparency because of the high level of trust it enjoys. 'We have not been good at educating the public on issues such as why we do a lot of

campaigning,' he says. 'But, the more high profile the sector becomes, the more people will ask questions.

Baroness Onora O'Neill, chair of the Nuffield Foundation, says building trust goes deeper than providing information. She points out that the additional reporting and accounting requirements imposed on institutions across all sectors in recent years may have made them more transparent, but it has not made them more trusted. If we are to judge for ourselves, we need genuine communication in which we can question and observe, check and even challenge the evidence that others present. Laying out the evidence of what has been done, with all its shortcomings, may provide a rather better basis for placing – or refusing trust than any number of glossy publications that trumpet unending success.

Not everyone thinks the public needs to be spoon-fed reams of information to maintain confidence. 'There isn't any evidence that there is a crisis of confidence in charities,' says Cathy Pharoah, research director at the Charities Aid Foundation. The facts support her claim. In a Charity Commissions report published in November last year, the public awarded charities 63 out of 10 on trust. Pharoah believes key donors are savvier than they are portrayed. 'There is heavy dependence on middle-class donors for charity income, and I would be amazed if they didn't realise charities had to pay to get professional staff, she says.

She believes the biggest threats to trust are the kind of scandals that blighted the Scottish voluntary sector in 2003. Two high-profile charities, Breast Cancer Research (Scotland) and Moonbeams, were exposed for spending a fraction of their profits on their causes. The revelations created intensely damaging media coverage. Even charity stalwarts were shocked by how quickly the coverage snowballed as two bad stories turned into a sector-wide crisis. 'Those two incidents caused a media frenzy as journalists took every opportunity to undermine the sector,' says Fiona Duncan, director of external affairs at Capability Scotland. After suffering a media grilling herself, Duncan launched Giving Scotland to redress the balance. Fourteen charities plus the Scottish council for Voluntary Organisations and the institution of Fund Raising Scotland Joined together to put out communications restoring confidence in charities. The Scottish executive pledged £30,000 and with donations from corporate supporters, the campaign was able to secure advertising worth £300,000 for a lightning two week campaign over Christmas 2003.

Two months before the campaign was launched, The Herald newspaper published a poll revealing that 52 per cent of the people were less likely to give because of the scandals. Giving Scotland did a similar poll in February 2004 and this time more than half of the population said they were more likely to consider giving because of the campaign. 'We learned about strength in numbers, and the importance of timing - because it was Christmas we were able to get good coverage,' says Duncan.

It was an effective rearguard campaign. The numerous proactive initiatives now underway across the UK give charities the chance to prevent the situation ever getting that bad again – but their success will depend on whether they are prepared to shed their saintly image and rally to the cause of creating a newer, bolder one.

**Questions 27-33** Choose the correct letter A, B, C or D

27. What do we learn about charities in the first paragraph
- People trust charities because they are approved by government
  - Not all the funds a charity receives go on practical aid for people
  - Charities do not disclose their systems for fear of losing official status
  - People who work for charities without pay are not fit for the job.
28. Why, in the writer's view is it hard for charities to inform the public properly
- They calculate their success differently from other businesses
  - They are unable to publish a true financial report.
  - The amount of resources needed changes radically, year by year
  - Donors may be disappointed if they see large profits in the business

29. One of the conclusions of the report 'Funding Success' is that
- Charities must cut down on any unnecessary expenditure.
  - Raising more money for their cause should be the charity's main aim
  - Charities should give the public an assessment of the results of their work.
  - Clarifying the reasons for administration costs would not dissuade donors
30. Baroness O' Neill's main recommendation is that charities should
- Follow the current government's requirements on reporting.
  - Encourage the people to examine and discuss the facts
  - Publicize any areas in which they have been effective.
  - Make sure the figures are laid out as clearly as possible.
31. What is Cathy Pharoah most concerned about
- The public's adverse reaction to the money spent on charity personnel
  - The effect on general donations if a charity misuses their funds
  - The reliance of many charities on a single sector of the population
  - The findings of a Charity Commissions report on public confidence
32. Why does Fiona Duncan think the Giving Scotland campaign succeeded
- The message came over strongly because so many organisations united
  - People did not believe the critical stories that appeared in newspapers
  - Private donors paid for some advertising in the national press
  - People forgot about the scandals over the Christmas holidays
33. The writer suggests that in the future charities
- May well have to face a number of further scandals
  - Will need to think up some new promotional campaigns
  - May find it hard to change the public's perception of them.
  - Will lose the public's confidence if they modernise their image

#### Questions 34-40

Do t be following statements agree with the information given in Reading Passage 3

**TRUE** if the statement agrees with the information

**FALSE** if the statement contradicts the information

**NOT GIVEN** if there is no information on this

34. Charity involvement in some prominent campaigns has meant that they are undergoing more careful examination by the public.
35. Famous people insist on a large fee if they appear for a charity
36. The new RNID documents outline expected progress as well as detailing past achievements
37. People have been challenging the RNID on their promotional activities
38. The two charities involved in a scandal have altered their funding programme
39. Following the scandal, the media attacked the charity sector as a whole
40. Charity donations in Scotland are back to their pre-scandal level

**Achieve IELTS Reading 3****Reading Passage 1**

Reading passage 1 has six paragraphs, A-F. Choose the correct heading for each paragraph A-F from the list below

**List of Headings**

xi.	The benefits of simple language
xii.	A necessary tool
xiii.	A lasting way of concealing disasters
xiv.	The worst offenders
xv.	A deceptively attractive option
xvi.	Differing interpretations
xvii.	Publicising new word
xviii.	Feeling shut out
xix.	Playing with words

1. Paragraph A
2. Paragraph B
3. Paragraph C
4. Paragraph D
5. Paragraph E
6. Paragraph F

**Jargon**

- A. Jargon is a loaded word. One dictionary defines it, neatly and neutrally, as 'the technical vocabulary or idiom of a special activity or group', but this sense is almost completely overshadowed by another: 'obscure and often pretentious language marked by a roundabout way of expression and use of long words'. For most people, it is this second sense which is at the front of their minds when they think about jargon. Jargon is said to be a bad use of language, something to be avoided at all costs. No one ever describes it in positive terms ('that was a delightful piece of rousing jargon'). Nor does one usually admit to using it oneself; the myth is that jargon is something only other people employ.
- B. The reality, however, is that everyone uses jargon. It is an essential part of the network of occupations and pursuits that make up society. All jobs present an element of jargon, which workers learn as they develop their expertise. All hobbies require mastery of a jargon. Each society grouping has its jargon. The phenomenon turns out to be universal - and valuable. It is the jargon element which, in a job, can promote economy and precision of expression and thus help make life easier for the worker. It is also the chief linguistic element which shows professional awareness ('know-how') and social togetherness ('shop-talk').
- C. When we have learned to command it, jargon is something we readily take pleasure in, whether the subject area is motorcycles, knitting, cricket, baseball or computers. It can add pace, variety and humour to speech - as when, with an important event approaching, we might slip into NASA-speak, and talk about countdown, all systems go, and lift-off. We enjoy the mutual showing-off which stems from a fluent use of terminology, and we enjoy the in-jokes which shared linguistic experience permits. Moreover, we are jealous of this knowledge. We are quick to demean anyone who tries to be part of our group without being prepared to take on its jargon.
- D. If Jargon is so essential a part of our lives, why then has it had such a bad press? The most important reason stems from the way jargon can exclude as well as include. We may not be too concerned if we find ourselves faced with an impenetrable wall of jargon when the subject matter has little perceived relevance to our everyday lives, as in the case of hydrology say, or linguistics. But when the subject matter is one where we feel implicated and think we have a right to know, and the speaker uses words which make it hard for us to understand, then we

start to complain, and if we suspect that the obfuscation is deliberate policy, we unreservedly condemn, labelling it gobbledegook and calling down public derision upon it.

- E. No area is exempt, but the fields of advertising, politics and defence have been especially criticised in recent years by the various campaigns for Plain English. In these domains, the extent to which people are prepared to use jargon to hide realities is a ready source of amusement, disbelief and horror. A lie is a lie, which can be only temporarily hidden by calling it an 'inoperative statement' or 'an instance of plausible deniability'. Nor can a nuclear plant explosion be suppressed for long behind such phrases as 'energetic disassembly', 'abnormal evolution' or 'plant transient'.
- A. While condemning unnecessary or obscuring jargon in others, we should not forget to look out for it in ourselves. It is so easy to 'slip into' jargon, without realising that our own listeners / readers do not understand. It is also temptingly easy to slip some jargon into our expression, to ensure that others do not understand. And it is just as easy to begin using jargon which we ourselves do not understand. The motivation to do such apparently perverse things is not difficult to grasp. People like to be 'in', to be part of an intellectual or technical elite; and the use of jargon, whether understood or not, is a badge of membership. Jargon, also, can provide a lazy way into a group or an easy way of hiding uncertainties and inadequacies: when terminology slips plausibly from the tongue, it is not essential for the brain to keep up. Indeed some people have developed this skill to professional levels. And certainly, faced with a telling or awkward question, and the need to say something acceptable in public, slipping into jargon becomes a simple way out, and can soon become a bad habit.

**Questions 7 - 12** Complete the summary using the list of words A - L below

**The Up Side of Jargon**

Jargon plays a useful part in many aspects of life including leisure. For example, when people take up pastimes they need to develop a good 7 .....of the relevant jargon. During discussion of these or other areas of interest, conversation can become more exciting and an element of a 8.....can be introduced by the use of shared jargon.

Jargon is particularly helpful in the workplace. It leads to more 9.....in the way colleagues communicate during work hours. Taking part in 10..... during moments of relaxation can also help them to bond better.

It is interesting that members of a group, whether social or professional, often demonstrate a certain 11.....towards the particular linguistic characteristics of their subject area and tend to regard new people who do not wish to learn the Jargon with 12.....

- A. judgement
- B. jokes
- C. shop-talk
- D. efficiency
- E. know-how
- F. command
- G. contempt
- H. feeling
- I. possessiveness
- J. pleasure
- K. fear
- L. humour

**Question 13** Choose the correct letter A, B, C or D

- 13 Which of the following statements would the writer agree with?
- A. Jargon thoroughly deserves the bad reputation it has gained.
  - B. Jargon should not be encouraged except in the workplace.
  - C. Jargon should not be used if the intention is to exclude others.
  - D. Everyday life would be very much better without jargon.

## READING PASSAGE 2

**Healthy Intentions**

*Most of us have healthy intentions when it comes to the food we eat. But it can be tough. Especially when you consider that our bodies have not properly adapted to our highly processed fast food diets.*

A. One hundred years ago, the leading causes of death in the industrial world were infectious diseases such as tuberculosis, influenza and pneumonia. Since then the emergence of antibiotics, vaccines and public health controls has reduced the impact of infectious disease. Today, the top killers are non-infectious illnesses related essentially to lifestyle (diet smoking and lack of exercise). The main causes of death in the United States in 1997 were heart disease, cancer and stroke. Chronic health problems, such as obesity, noninsulin-dependent diabetes and osteoporosis, which are not necessarily lethal but nonetheless debilitating, are steadily increasing. It is clear that economic and technical progress is no assurance of good health.

B. Humans are quantitatively different from other animals because we manipulate the flow of energy and resources through the ecosystem to our advantage, and consequently to the detriment of other organisms. That is why we compete so successfully with other species. But with this success come some inherent failings, particularly in terms of our health.

C. According to physician Boyd Eaton and his anthropologist colleagues, despite all our technological wizardry and intellectual advances, modern humans are seriously malnourished. The human body evolved to eat a very different diet from that which most of us consume today. Before the advent of agriculture, about ten thousand years ago, people were hunter-gatherers, the food varying with the seasons and climate and all obtained from local sources. Our ancestors rarely, if ever, ate grains or drank the milk of other animals.

D. Although ten thousand years seems a long time ago, 99.99 percent of our genetic material was already formed. Thus we are not well adapted to an agricultural based diet of cereals and dairy products. At least 100,000 generations of people were hunter-gatherers, only 500 generations have depended on agriculture, only ten generations have lived since the onset of the industrial age and only two generations have grown up with highly processed fast foods. Physician Randolph Nesse and George Williams write: 'Our bodies were designed over the course of millions of years for lives spent in small groups hunting and gathering on the plains of Africa. Natural selection has not had time to revise our bodies for coping with fatty diets, automobiles, drugs, artificial lights and central heating. From this mismatch between our design and our environment arises much, perhaps most, preventable modern disease.'

E. Do we really want to eat like prehistoric humans? Surely 'cavemen', were not healthy? Surely their life was hard and short? Apparently not. Archaeological evidence indicates that these hunter-gatherer ancestors were robust, strong and lean with no sign of osteoporosis or arthritis – even at more advanced ages. Palaeolithic humans ate a diet similar to that of wild chimpanzees and gorillas today: raw fruit, nuts, seeds, vegetation, fresh untreated water, insects and wild-game meat low in saturated fats. Much of their food was hard and bitter. Most important, like chimpanzees and gorillas, prehistoric humans ate a wide variety of plants - an estimated 100 to 300 different types in one year. Nowadays, even health-conscious, rich westerners seldom consume more than twenty to thirty different species of plants.

F. The early human diet is estimated to have included more than 100 grams of fibre a day. Today, the recommended level of 30 grams is rarely achieved by most of us. Humans and lowland gorillas share similar digestive tracts - in particular, the colon – but, while gorillas derive up to 60 percent of their total energy from fibre fermentation in the colon, modern humans get only about 4 percent. When gorillas are brought into captivity and fed on lower-fibre diets containing meat and eggs, they suffer from many common human disorders: cardiovascular disease, ulcerative colitis and high cholesterol. Their natural diet, rich in antioxidant and fibre apparently prevent these



diseases in the wild, suggesting that such a diet may have serious implications for our own health.

G. Not all agricultural societies have taken the same road. Many traditional agriculturalists maintain the diversity of their diet by eating a variety of herbs and other plant compound, along with meat and grain. The Huasa people of northern Nigeria, for example, traditionally include up to twenty wild medicinal plants in their grain-based soups, and peoples who have become heavily reliant on animal products have found ways of countering the negative effects of such a diet. While the Masai of Africa eat meat and drink blood, milk and animal fat as their only sources of protein, they suffer less heart trouble than Westerners. One reason is that they always combine their animal products with strong, bitter antioxidant herbs. In other words, the Masai have balanced the intake of oxidising and anti-oxidising compounds. According to Timothy Johns, it is not the high intake of animal fat or the low intake of antioxidants, that creates so many health problems in industrial countries; it is the lack of balance between the two.

H. Eating the right foods and natural medicines requires a sensitivity to subtle changes in appetite. Do I fancy something sweet, sour, salty, stimulating or sedating? What sort of hunger is it? And after consumption, has the need been satisfied? Such subtleties are easily overridden by artificially created super-stimuli in processed foods that leave us unable to select a healthy diet. We need to listen more carefully to our bodies' cravings and take an intentional role in maintaining our health before disease sets in.

#### Questions 14 - 20

Reading passage 2 has seven paragraphs, A-G. Which paragraph contains the following information? You may use any letter more than once.

14. a reference to systems for neutralising some harmful features of modern diets
15. a suggestion as to why mankind has prospered
16. an example of what happens if a balanced, plant-based diet is abandoned
17. a chronological outline of the different types of diet mankind has lived on
18. details of which main factors now threaten human life
19. a reference to one person's theory about the cause of some of today's illnesses
20. detail of the varied intake of early humans

#### Question 21 -26

Do the following statements agree with the claims of the writer in Reading passage 2

- TRUE                                   if the statement agrees with the information  
 FALSE                                   if the statement contradicts the information  
 NOT GIVEN                           if there is no information on this

21. An increase in material resources leads to improved physical health.
22. Cereals were unknown to our hunter-gathering ancestors
23. In the future, human bodies will adapt to take account of changes in diet.
24. Many people in developed countries have a less balanced diet than early humans.
25. Gorillas that live in the wild avoid most infectious diseases.
26. Food additives can prevent people from eating what their bodies need.

#### Passage 3

### Educational and Professional Opportunities for Women in New Technologies

The principle that you don't have to be a mechanic to drive a car can also be applied to Information and Communication Technologies (ICTs). Gone are the days when a computer user needed knowledge of a programming language. On one hand, this is good news for women. This is because women can now use computer without needing computer science qualifications that gives ICTs the potential to enhance women's education. But, our lack of ICT skills is not praiseworthy. Feminist writers for many years have argued that if more women were engineers and scientists, we might live in a very different world. (Rothschild 1982)

In a review of five countries, Millar and Jagger examined women's employment in ICT occupations. They found a pattern of a low proportion of female entrants, a significant 'leaking' (Alper 1993) of those who enter to other areas of employment, and a ghetto of women in lower paid jobs. How did a new area of economic activity become gendered so quickly? An obvious answer could be that men have seen it as a desirable area and women have not.

It is often said that new industries are both 'gender blind' (i.e. if you are good at your work you'll succeed whatever your gender) and that they value 'feminine' communication and 'people' skills. But recent research does not bear this out. A study of a new high-tech ICT company (Woodfield 2000) employing highly qualified graduate, showed that men were given management responsibility despite an acknowledgement by the company that they had poor management skills. And there was an unwillingness to give responsibilities to women who had these skills. It seems that jobs acquire gender quite quickly in some sectors.

In the 1980s and 1990s, interesting studies were done into the ways in which men and women think about the world. They argued for the validation of diverse ways of thinking, rather than a hierarchy with a particular kind of male intellectual tradition at the apex. Turkle (1984; 1996) has done similar work on the way people interact with computers. She sees computers as tools used as an extension of our identities, with significant variations in the ways that men and women use them to explore and perform their gendered identities. This subtle way of understanding our relationship with this technology however, must go in parallel with a materialist view, which is that an underlying motivation for most ICT-based initiatives in work, education, leisure, citizenship is economic force.

We must also differentiate between the opportunities for employment offered by ICTs, and the tools they provide for education. We must beware of the inappropriate application of ICTs to a problem that would be better addressed in another way. Research into the effectiveness of ICTs as measured by student performance in Maths, suggests that for young children there is a negative relationship between classroom computer use and Maths performance. One researcher, Angrist, from MIT found when examining ICTs in the classroom that the set-up costs were obvious and the benefits much less so (Economist 2002). It could be more effective to have more teacher involvement and lower class sizes.

In 1963 Clark Kerr, the President of the University of California, coined the term 'multiversity', to suggest that universities were no longer based on a body of universal knowledge or a heterogeneous body of students. Higher education, professional education and life skills education are now being delivered by a variety of different universities, colleges and commercial companies. The distinctions between these are breaking down. Just when women are getting equal access to higher education and professional education, what constitutes higher level education and valid scholarly activity has been called into question through the creation of virtual universities. On the other hand, women are often claimed to have the most to gain from these new flexible and distributed kinds of education.

Although online education provides new opportunities for women it is also the source of new pressures. The term 'Second Shift' was invented to identify the work/life balance of employed women. Women in paid employment did not substitute this for their domestic work; they struggled to carry out both obligations. Kramarae sees education in the new century as the 'Third Shift': 'As life long learning and knowledge become ever more important, women and men find they juggle not only the demands of work and family, but also the demands of further education throughout their lives.' (2001)

ICTs - the internet in particular - are seen as providing global access to key educational resources. However, access to information is a useless resource if you don't have the skills to evaluate and use it. Shade (2002) distinguishes between the feminisation of the Internet, where women are targeted as consumers rather than citizens or learners and feminist uses of the Internet where women develop content that creates opportunities for women.

Digital media may also produce inflexibility for women engaged in learning. A survey of open and distance learning students (Kirkup and Prummer 1997: Kirkup 2001) demonstrated differences in the preferred learning styles of women and men. Women were uncomfortable with isolation and stated a desire for connection with others. Engagement in creating and maintaining networks and relationships is often cited as a reason why computer-mediated communication will be a 'female' technology. Unfortunately, however, empirical work challenges this. Li (2002), in a study of university students in the UK and China, found that male students used e-mail more frequently, spent more time online and engaged in more varied activities than women students. There is now a wealth of research on the gender differences of male and female online activity, all of which demonstrate the online environment creating a gendered world operating in similar ways to the material world.

#### **Question 27 -34**

Look at the following people (Questions 27 -34) and the list of reported findings below. Match each person with the correct finding. A- K.

27. Rothschild
28. Alper
29. Woodfield
30. Turkle
31. Angrist
32. Shade
33. Kirkup
34. Li

#### **List of Reported Findings**

- A. Men and women perceive their environment differently.
- B. The advantages of ICTs in schools are difficult to pacify.
- C. Men see ICTs as an exciting new area of employment.
- D. Female students find working on their own unappealing.
- E. A greater female representation in scientific and technical posts would have enormous benefits
- F. Women can be seen as both passive and active users of ICTs
- G. Female students can benefit most from ICTs and distance learning.
- H. In Higher Education, men use a wider range of ICT skills than women.
- I. A considerable number of women give up ICT posts to work in different fields.
- J. The way the two genders regard computers reflects the differences in the way they develop their sense of self.
- K. Certain new employment sectors are soon colonized by workers of one sex.

#### **Question 35 -40**

*Complete the sentences below. Choose NO MORE THAN THREE WORDS AND/OR A NUMBER from the passage for each answer.*

35. The term .....refers to a company that is equally happy to promote workers of either sex.
36. It is clear that ICT developments in most fields are driven by.....
37. The range of institutions providing high level instruction today is known as a .....
38. Women who are working find it hard to get their.....right.
39. The way workers of both sexes now face having to fit children, work and continued learning into their lives is called the .....
40. Women are thought to be suited to computer work as it involves developing .....and .....

Achieve IELTS Reading 4**Ocean Acidification**

*Caspar Henderson reports on some new concerns.*

A few years ago, biologist Victoria Fabry, saw the future of the world's oceans in a jar. She was aboard a research ship in the North Pacific, carrying out experiments on a species of pteropod - small molluscs with shells up to a centimetre long, which swim in a way that resembles butterfly flight, propelled by small flaps. Something strange was happening in Fabry's jars. 'The pteropods were still swimming, but their shells were visibly dissolving,' says Fabry. She realised that the animals' respiration had increased the carbon dioxide (CO<sub>2</sub>) in the jars, which had been sealed for 48 hours, changing the water's chemistry to a point where the calcium carbonate in the pteropods' shells had started to dissolve. What Fabry had stumbled on was a hint of 'the other CO<sub>2</sub> problem'.

It has taken several decades for climate change to be recognised as a serious threat. But another result of our fossil-fuel habit - ocean acidification - has only begun to be researched in the last few years. Its impact could be momentous, says Joanie Kleypas of the National Centre for Atmospheric Research in Boulder Colorado.

CO<sub>2</sub> forms carbonic acid when it dissolves in water, and the oceans are soaking up more and more of it. Recent studies show that the seas have absorbed about a third of all the fossil-fuel carbon released into the atmosphere since the beginning of the industrial revolution in the mid-eighteenth century, and they will soak up much more over the next century. Yet until quite recently many people dismissed the idea that humanity could alter the acidity of the oceans, which cover 71 % of the planet's surface to an average depth of about four kilometres. The ocean's natural buffering capacity was assumed to be capable of preventing any changes in acidity even with a massive increase in CO<sub>2</sub> levels.

And it is - but only if the increase happens slowly, over hundreds of thousands of years. Over this timescale, the release of carbonates from rocks on land and from ocean sediments can neutralise the dissolved CO<sub>2</sub>, just like dropping chalk in an acid. Levels of CO<sub>2</sub> are now rising so fast that they are overwhelming the oceans' buffering capacity.

In 2003 Ken Caldeira of the Carnegie Institution in Stanford, and Michael Wickett at the Lawrence Livermore National Laboratory, calculated that the absorption of fossil CO<sub>2</sub> could make the oceans more acidic over the next few centuries than they have been for 300 million years, with the possible exception of rare catastrophic events. The potential seriousness of the effect was underlined in 2005 by the work of James Zachos of the University of California and his colleagues, who studied one of those rare catastrophic events. They showed that the mass extinction of huge numbers of deep-sea creatures around 55 million years ago was caused by ocean acidification after the release of around 4500 giga-tonnes of carbon. It took over 100,000 years for the oceans to return to their normal state.

Around the same time as the Zachos paper, the UK's Royal Society published the first comprehensive report on ocean acidification. It makes grim reading, concluding that ocean acidification is inevitable without drastic cuts in emissions. Marine ecosystems, especially coral reefs, are likely to be affected, with fishing and tourism based around reefs losing billions of dollars each year. Yet the report also stressed that there is huge uncertainty about the effects on marine life.

The sea creatures most likely to be affected are those that make their shells or skeletons from calcium carbonate, including tiny plankton and huge corals. Their shells and skeletons do not dissolve only because the upper layers of the oceans are supersaturated with calcium carbonate. Acidification reduces carbonate ion concentrations, making it harder for organisms to build their shells or skeletons. When the water drops below the saturation point, these structures will start to dissolve. Calcium carbonate comes in two different forms, aragonite and calcite, aragonite being more soluble. So organisms with aragonite structures such as corals will be hardest hit.

So far the picture looks relentlessly gloomy, but could there actually be some positive results from adding so much CO<sub>2</sub> to the seas? One intriguing finding, says Ulf Riebesell of the Leibniz institute of Marine Sciences in Kiel Germany, concerns gases that influence climate. A few experiments suggest that in more acidic conditions, microbes will produce more volatile organic compounds such as di-methyl sulphide, some of which escapes to the atmosphere and causes clouds to develop. More clouds would mean cooler conditions, which could potentially slow global warming.

Calculating the effect of ocean acidification on people and economies is virtually impossible, but it could be enormous. Take the impact on tropical corals, assuming that warming and other pressures such as pollution do not decimate them first. Reefs protect the shorelines of many countries. Acidification could start eating away at reefs just when they are needed more than ever because of rising sea levels.

'No serious scientist believes the oceans will be devoid of life,' says Caldeira. 'Wherever there is light and nutrients, something will live. A likely outcome will be a radical simplification of the ecosystem. 'Taking this and other scientists' views into account, it seems clear that acidification will mean the loss of many species so our children will not see the amazingly beautiful things that we can. It is important to tell them to go and see the corals now before it is too late.

### Questions 1 - 7

Answer the questions below. Choose NO MORE THAN THREE WORDS AND / OR A NUMBER for each answer

1. What does the pteropod use to move itself through the water?
2. Which part of the pteropods was being damaged by increased acidification?
3. What proportion of the carbon released over the last 200 years has been taken in by the oceans?
4. Where do carbonates enter the oceans from?
5. How long did the oceans need to recover after the destruction of marine life by acidification 55 million years ago?
6. Which businesses will suffer if reefs are damaged?
7. What type of creatures make their skeleton out of aragonite?

### Questions 8 - 12

Complete the flow-chart below. Choose NO MORE THAN THREE WORDS AND/OR A NUMBER from the passage for each answer.

#### A Possible Benefit from Increased CO<sub>2</sub> Levels in the Sea

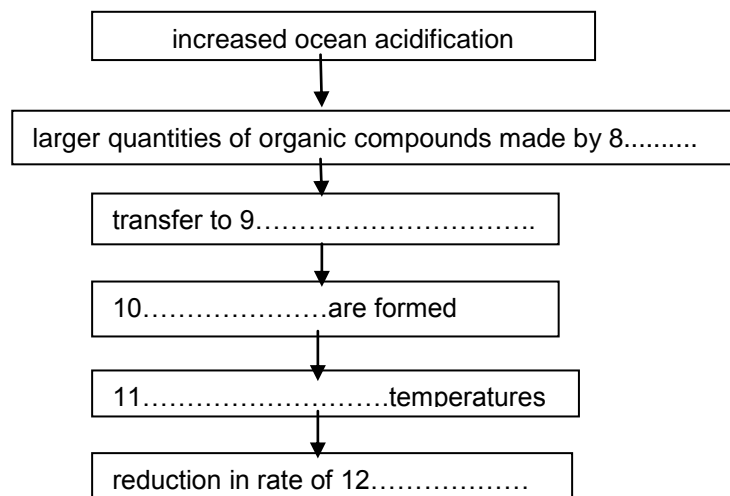

### Question 13

Choose the correct letter A, B, C or D

13. Which of the following statements best summarises the writer's view in the passage?
  - A. We will have to wait and see if acidification has serious effects.
  - B. It is clear that acidification will cause huge damage to marine life.
  - C. It is likely that increased CO<sub>2</sub> will change marine ecosystems considerably.
  - D. The theory that increased CO<sub>2</sub> could have positive results is believable.

## PASSAGE 2

**A New Fair Trade Organisation**

*Trade has, so far proved ineffective in solving the major problems faced by most nations. However, the answer to the injustices of the existing trade regime is not no trade, but fair trade.* The existing regime forbids poor nations from following the path taken by the rich. With the exceptions of Switzerland, Belgium and the Netherlands, all the nations that have become independently wealthy did so with the help of a mechanism economists call 'infant industry protection': defending new sectors from foreign competition until they are big enough to compete on equal terms. The textile industry in Britain, for example, on which the Industrial Revolution was built in the nineteenth century, was nurtured and promoted by means of tariffs (or trade taxes) and the outright prohibition of competing goods. Between 1864 and 1913, the US was the most heavily protected nation on earth. Only when these countries had established technological and commercial superiority did they suddenly discover the virtues of unimpeded competition.

For nations to develop direct competitions with countries with established industries is like learning to swim in a fast flowing river: you are likely to be swept away and drowned long before you acquire the necessary expertise. Your competitors have experience, legal rights and established marketing networks on their side; your infant industries have none of these. It is all but impossible, in other words, for poor nations to extract money from the rich unless they can safeguard some key parts of their economies.

Clearly, nations that are currently poor should be permitted to defend certain industries from foreign competition with the help of tariff barriers and subsidies. Rich nations on the other hand should be permitted neither to subsidise their industries, nor to impose tariffs on imports. Nations should be forced gradually to lift their protections as they develop. So the first function of what we might call the Fair Trade Organisation (FTO) would be to lay down the rules governing the protections and privileges permitted at different stages of development

A fair-trade system should, or so we should hope slowly push the world towards genuine free trade, which is likely to be the most equitable means of governing nations' relationships with each other. This system could provide a potent means by which the world could begin to move towards the economic equality that is an essential precondition for political equality. It would not however, directly address some of the other critical problems that the people of poor nations confront – such as inadequate working conditions, environmental devastation and the inordinate power of the multinational corporations.

Many campaigners in the rich world have suggested that the best way to raise standards is to discriminate through tariffs or other measures against imports from countries where workers or the environment are mistreated. This approach has also been advocated by trades unions seeking to protect members' jobs from foreigners. Unsurprisingly, it is deeply resented by the very people it is supposed to help: the workers of the poor world.

If our purpose is to regulate international trade, then it surely makes sense to address the behaviour, not of nation states, but of the multinational corporations operating between them. So a second function of the FTO could be to set the standards to which those corporations must conform. A corporation would not be permitted to trade between nations unless it could demonstrate that, at every stage of manufacturing and distribution, its own operations and those of its suppliers met the necessary standards.

If, for example, a food-processing corporation based in Europe wished to import cocoa from an African country, it would need to demonstrate that the plantation owners it bought from were not using banned pesticides expanding into protected forests or failing to conform to whatever other standards the FTO set. The company's performance would be assessed, at its own expense, by monitors accredited to the organisation.

One other precondition of Justice is that producers and consumers should carry their own costs, rather than dumping them on other people. The monitors deployed by the FTO could determine whether or not companies are paying a fair price for the resources they use. Companies would, among other costs have to buy enough of a nation's carbon quota to cover the fossil fuel they consume.

One of the many beneficial impacts of such full-cost accounting would be that everything that could be processed in the country of origin would be. No multinational company would export logs, coffee beans or cotton, as it requires far more (costly) energy to transport these bulky resources from one place to another than would be involved in exporting the finished products – furniture, instant coffee and T-shirts (all currently manufactured on the other side of the world). Those nations which are currently located into the export of raw materials would become the most favoured locations for manufacturing.

Under this scheme, export growth comes to measure something quite different. At present it represents a mixture of gains and losses, which are misleadingly compounded into a single figure. The loss of natural resources is 'added' to the genuine addition or value provided by the application of labour. The FTO system would effectively separate these measures. The extraction and export of natural resources would in most cases be accounted as a loss. The application of human labour would be measured as a gain. Nations would be able to see immediately whether they were being enriched or impoverished through trade. To introduce these measures in the face of the resistance of the world's most powerful governments and companies would require severe and unusual methods. But the goal of universal fair trade would permit the global economic levelling without which there can be no justice.

#### Questions 14-19

Choose the correct letter A, B, C or D

14. The writer refers to textile production in Britain in order to
  - A. point out how differently industries were financed in the past.
  - B. show how unnecessary tariff barriers are for countries today
  - C. help the reader understand how infant industry protection works
  - D. compare European trade development with that of the United States
15. What is the writer's main point in the third paragraph
  - A. Businesses will succeed if they learn from established companies.
  - B. Detailed market research is often neglected in developing countries.
  - C. You have to be prepared to adapt your products quickly to follow fashion
  - D. New industries in poor countries will probably fail without protection
16. According to the writer a fair trade system could have the effect of
  - A. Improving safety in the majority of workplaces in the world.
  - B. preventing the continued destruction of endangered wildlife habitat
  - C. encouraging states to work together in a more even-handed way
  - D. making politicians agree to more representative systems of government.
17. What point is the writer making in the sixth paragraph?
  - A. The trades unions' aim is to help foreign workers gain better conditions
  - B. The trades unions are concerned about the effect of import on local jobs
  - C. Workers in poor countries are grateful for the trades unions' support
  - D. Campaigners are right to suggest imposing tariffs against bad treatment
18. According to the writer what is one of the benefits of full-cost accounting
  - A. Factories would be set up and jobs created in the country or origin.
  - B. Multinational companies would consume fewer natural resources
  - C. The export of finished products around the world would decrease
  - D. Countries would be able to keep their resources for the domestic market
19. What conclusion does the writer come to about the FTO system
  - A. It would help to combat injustice in its many different forms.
  - B. It would be difficult to introduce but would be worth the effort
  - C. States all over the world would earn more through trade as a result of it
  - D. Multinationals would accept it because it measures exports more precisely

**Questions 20-26**

Complete the summary below. Choose NO MORE THAN TWO WORDS from the passage for each answer.

**A Proposal for Regulating Multinational Corporations**

The FTO would determine the 20.....for the multinational corporations to follow. In this way, a multinational corporation would have to prove that all aspects of the way it produced its goods and the systems for their 21..... to customers was in line with FTO requirements. Similarly it would need to satisfy the FTO that the processes employed by any 22..... that it used were also acceptable.

As an illustration, in order to source cocoa from Africa, a corporation would have to ensure that no illegal 23.....were being used by the 24.....during cultivation and that they had not taken over land from 25.....

It would not be sufficient for multinational corporations to say that these points had been checked. Their conduct would have to be inspected by 26.....appointed by the FTO.

**Passage 3****The First Antigravity Machine?**

It was one of the biggest science stories of the 1990s. Even now, the facts behind it remain hotly disputed. And small wonder, for if the claims made for the small disc, the focus of the controversy, are true, it may be possible to break through one of the great barriers in the scientific world and control the most potent of cosmic forces: gravity. Huge innovations in flight and space travel could arise from that.

The first gravity-blocking system to be taken seriously by scientists appeared in a laboratory in Tampere University of Technology, Finland. A Russian scientist named Dr Evgeny Podkletnov created a disc 275mm across, made from a substance which combined copper, barium and the 'rare Earth metal' called yttrium, which is known to be a high-temperature superconductor (a substance that conducts electricity without resistance). When chilled with liquid nitrogen at  $-196^{\circ}\text{C}$  (a high temperature compared with other superconductors), this material loses all its electrical resistance, and can levitate (lift) in a magnetic field. That may seem amazing for a ceramic-like material - and it won a Nobel Prize for the scientists Karl Muller and Johannes Bednorz, who first demonstrated it in the 1980s. But according to Podkletnov, the disc had another far more astounding property.

In 1992, while experimenting with rotating superconductors, Podkletnov noticed that pipe-smoke from a nearby researcher was drifting into a vertical column above the spinning disc. Intrigued by this phenomenon, he decided to devise an experiment to investigate further. A superconductive disc, surrounded by liquid nitrogen was magnetically levitated and rotated at high speed - up to 5,000 revolutions per minute (rpm) in a magnetic field. An object was suspended from a sensitive balance above the disc. It was enclosed in a glass tube to shield it from any effects of air currents. During the course of a series of tests, Podkletnov was able to observe that the object lost a variable amount of weight from less than 0.5 percent to 2 percent of its total weight. The effect was noted with a range of materials from ceramics to wood. The effect was slight, yet the implications were revolutionary: the disc appeared to be partly shielding the object from the gravitational pull of the earth.

This was just the start, claimed Podkletnov. While far short of the 100 percent reduction in weight needed to send astronauts into space, for example, it was infinitely greater than the amount predicted by the best theory of gravity currently in existence. Einstein's theory of general relativity (GR), published in 1905. According to Einstein, gravity is not some kind of 'force field' like magnetism, which can - in principle at least - be screened out. Instead, GR views gravity as a distortion in the very fabric of space and time that permeates the whole cosmos. As such, any claim to have shielded objects from gravity is to defy Einstein himself.

Podkletnov's claims were subjected to intense scrutiny when he submitted them for publication. The UK institute of Physics had Podkletnov's paper checked by three independent referees, but none could find a fatal flaw. His research was set to appear in the respected Journal of Physics D



when events took an unexpected turn. The claims were leaked to the media, sparking world-wide coverage of his apparent breakthrough. Then Podkletnov suddenly withdrew the paper from publication and refused to talk to the press.

Rumours began to circulate of unknown backers, demanding silence until the device had been fully patented. But for many scientists the strange events were all too familiar. Podkletnov was just the latest in a long line of people to have made claims about defying gravity. Most of these have come from madcap inventors, with bizarre devices, often with some kind of spinning disc. But occasionally respectable academics have made such claims as well.

One instance of this occurred in the late 1980s when scientists at Tonoku University, Japan, made headlines with research suggesting that apparatus known as gyroscope, lost 0.01 percent of its weight when spinning at up to 13,000 rpm. Oddly the effect only appeared if the gyroscope was spinning anticlockwise - raising suspicions that some mechanical peculiarity was to blame. Attempts by scientists at the University of Colorado to replicate the effect failed.

Then Professor Giovanni Modanese, an Italian theoretical physicist, became interested. He had read an earlier paper by Podkletnov, hinting at a connection between superconductivity and gravity shielding. Modanese wondered if the magnetic field surrounding the superconductive disc might somehow assimilate part of the gravitational field under it. He published some calculations based on his idea in 1995 – and soon discovered that taking 'antigravity' seriously was a career-limiting move.

The revelations about Podkletnov's antigravity research led to reports of major corporations setting up their own studies. In 2000, the UK defence contractor BAE systems was said to have launched "Project Greenglow" to investigate Podkletnov's gravity shield effect. Then it emerged that the US aircraft builder Boeing was also investigating, suggesting it too had an interest in the effect. Groups in other countries were also rumoured to be carrying out studies. Yet not one of the teams had reported confirmation of the original findings. Some projects have been wound up without producing results either way. So for the time being, it seems that the dream of controlling gravity will remain precisely that.

#### **Question 35 -40**

Label the diagram below. Choose **NO MORE THAN THREE WORDS AND/OR A NUMBER** from the passage for each answer.

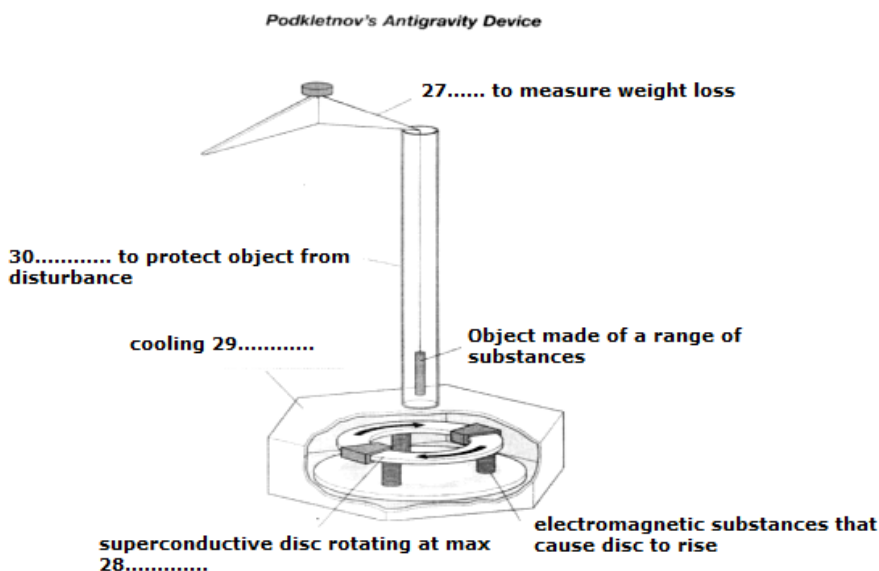

**Question 31- 35**

Classify the following as belonging to

- A. Podkletnov
- B. Tohoku University
- C. Modanese

- 31. The experiment only works if the equipment moves in a particular direction.
- 32. Varying amounts of weight are lost as a result of the test
- 33. Gravity could be absorbed by a magnetic field.
- 34. Superconductive material seems to scan an object from gravity
- 35. Weight loss occurs when the equipment rotates at speeds reaching 13,000 rpm

**Question 36-40**

Do the following statements agree with the claims of the writer in Reading passage3

- TRUE if the statement agrees with the information
- FALSE if the statement contradicts the information
- NOT GIVEN if there is no information on this

- 36. Podkletnov won a prize for his initial work on superconductive substances
- 37. A chance observation led Podkletnov to experiment with gravity blocking
- 38. Einstein challenged earlier experiments on antigravity
- 39. Modanese suffered professionally after following up Podkletnov's findings
- 40. An aircraft company announced that it had replicated Podkletnov's results.

## IELTS INTENSIVE COURSE - READING 1

## READING PASSAGE 1

**Bilingualism in Children****A**

One misguided legacy of over a hundred years of writing on bilingualism is that children's intelligence will suffer if they are bilingual. Some of the earliest research into bilingualism examined whether bilingual children were ahead or behind monolingual children on IQ tests. From the 1920s through to the 1960s, the tendency was to find monolingual children ahead of bilinguals on IQ tests. The conclusion was that bilingual children were mentally confused. Having two languages in the brain, it was said, disrupted effective thinking. It was argued that having one well-developed language was superior to having two half developed languages.

**B**

The idea that bilinguals may have a lower IQ still exists among many people particularly monolinguals. However, we now know that this early research was misconceived and incorrect. First such research often gave bilinguals an IQ test in their weaker language - usually English. Had bilinguals been tested in Welsh or Spanish or Hebrew, a different result may have been found. The testing of bilinguals was thus unfair. Second, like was not compared with like. Bilinguals tended to come from, for example, impoverished New York or rural Welsh backgrounds. The monolinguals tended to come from more middle class, urban families. Working class bilinguals were often compared with middle class monolinguals. So the results were more likely to be due to social class differences than language differences. The comparison of monolinguals and bilinguals was unfair.

**C**

The most recent research from Canada, the United States and Wales suggests that bilinguals are, at least, equal to monolinguals on IQ tests. When bilinguals have two well developed languages (in the research literature called balanced bilinguals), bilinguals tend to show a slight superiority in IQ tests compared with monolinguals. This is the received psychological wisdom of the moment and is good news for raising bilingual children. Take, for example, a child who can operate in either language in the curriculum in the school. That child is likely to be ahead on IQ tests compared with similar (same gender, social class and age) monolinguals. Far from making people mentally confused, bilingualism is now associated with a mild degree of intellectual superiority.

**D**

One note of caution needs to be sounded.

IQ tests probably do not measure intelligence. IQ tests measure a small sample of the broadest concept of intelligence. IQ tests are simply paper and pencil tests where only right and wrong answers are allowed. Is all intelligence summed up in such right and wrong, pencil and paper tests? Isn't there a wider variety of intelligences that are important in everyday functioning and everyday life?

**E**

Many questions need answering. Do we only define an intelligent person as somebody who obtains a high score on an IQ test? Are the only intelligent people those who belong to high IQ organisations such as MENSA? Is there social intelligence, musical intelligence, military intelligence, marketing intelligence, motoring intelligence, political intelligence? Are all or indeed any of these forms of intelligence measured by a simple pencil and paper IQ test which demands a single, acceptable solution to each question? Defining what constitutes intelligent behaviour requires a personal value judgement as to what type of behaviour and what kind of person is of more worth.

**F**

The current state of psychological wisdom about bilingual children is that, where two languages are relatively well developed, bilinguals have thinking advantages over monolinguals. Take an example. A child is asked a simple question: How many uses can you think of for a brick? Some children can give two or three answers only. They can think of

building walls, building a house and perhaps that is all. Another child scribbles away, pouring out ideas one after the other; blocking up a rabbits hole, breaking a window, using a bird bath, as a plumb line, as an abstract sculpture in an art exhibition.

**G**

Research across different continents the world shows that bilinguals tend to be more fluent, flexible, original and elaborate to this type of open ended question. The person who can think of a few answers tends to be termed a convergent thinker. They converge onto it few acceptable conventional answers. People who think of lots of different uses for unusual terms (e.g. a brick, tin can, cardboard box ) are called divergers. Divergers like a variety of answers to a question and are imaginative and fluent in their thinking,

**H**

There are other dimensions in thinking where approximately 'balanced' bilinguals may have temporary, and occasionally permanent advantages over monolinguals: increased sensitivity to communication, a slightly speedier movement through the stages of cognitive development, and being less fixed on the sounds of words and more centred on the meaning of words. Such ability to move away from the sound of words and fix on the meaning of words tends to be a (temporary) advantage for bilinguals around the ages four to six. This advantage may mean an initial head start in learning to read and learning to think about language.

**Questions 1-3**

Complete the sentences. Choose **NO MORE THAN THREE WORDS** from the passage for each answer.

1. For more than....., books and articles were wrong about the intelligence of bilingual children.
2. For approximately 40 years, there was a mistaken belief that children who spoke two languages were .....
3. It was commonly thought that people with a single.....were more effective thinkers.

**Questions 4-9**

Reading Passage 1 has eight paragraphs A-H. Choose the correct heading for paragraphs B-G from the list of headings below.

Example Paragraph A vii

4. Paragraph B
5. Paragraph C
6. Paragraph D
7. Paragraph E
8. Paragraph F
9. Paragraph G

List of Headings

- i. No single definition of intelligence
- ii. Faulty testing, wrong conclusion
- iii. Welsh research supports IQ testing
- iv. Beware: inadequate for testing intelligence
- v. International research supports bilingualism
- vi. Current thought on the advantage bilinguals have
- vii. Early beliefs regarding bilingualism
- viii. Monolinguals ahead of their bilingual peer
- ix. Exemplifying the bilingual advantage

**Questions 10-13**

Do the following statements agree with the information given in Reading Passage 1? Write

- TRUE** if the statement agrees with the information  
**FALSE** if the statement contradicts the information  
**NOT GIVEN** if there is no information on this

10. Balanced bilinguals have more permanent than temporary advantages over monolinguals.
11. Often bilinguals concentrate more on the way a word sounds than on its meaning.
12. Monolinguals learn to peak at a younger age than bilinguals.
13. Bilinguals just starting school might pick up certain skills faster than monolinguals.

## READING PASSAGE 2

**Changing Rules for Health Treatment**

People who are grossly overweight, who smoke heavily or drink excessively could be denied surgery or drugs. The National Institute for Health and Clinical Excellence (NICE), which advises on the clinical and cost effectiveness of treatments for the National Health Service (NHS) in the UK, said that in some cases the 'self-inflicted' nature of an illness should be taken into account.

NICE stressed that people should not be discriminated against by doctors simply because they smoke or were overweight. Its ruling should apply only if the treatment was likely to be less effective, or not work because of an unhealthy habit. The agency also insisted that its decision was not an edict for the whole NHS but guidance for its own appraisal committees when reaching judgements on new drugs or procedures. But the effect is likely to be the same.

NICE is a powerful body and the cause of much controversy. It is seen by some as a new way of rationing NHS treatment. Across the UK, primary care trusts (PCTs) regularly wait for many months for a NICE decision before agreeing to fund a new treatment. One group of primary care trusts is ahead of NICE. Three PCTs in east Suffolk have already decided that obese people would not be entitled to have hip or knee replacements unless they lost weight. The group said the risks of operating on them were greater, the surgery may be less successful and the joints would wear out sooner. It was acknowledged that the decision would also save money.

NICE said no priority should be given to patients based on income, social class or social roles at different ages when considering the cost effectiveness of a treatment. Patients should not be discriminated against on the grounds of age either, unless age has a direct relevance to the condition. NICE has already ruled that IVF should be available on the NHS to women aged 23 to 39 as the treatment has less chance of success in older women. It also recommends that flu drugs should be available to over-65s, as older people are more vulnerable.

But NICE also said that if self-inflicted factors meant that drugs or treatment would be less clinically and cost effective, this may need to be considered when producing advice for the NHS. They state that 'if the self-inflicted cause of the condition will influence the likely outcome of its particular treatment, then it may be appropriate to take this into account in some circumstances'. They acknowledge that it can be difficult to decide whether an illness such as a heart attack was self-inflicted in a smoker. 'A patient's individual circumstances may only be taken into account when there will be an impact on the clinical and cost effectiveness of the treatment.

Prof Sir Michael Rawlins, the chairman of NICE, said: 'On age we are very clear - our advisory groups should not make recommendations that depend on people's ages when they are considering the use of its particular treatment, unless there is clear evidence of a difference in its effectiveness for particular age groups. Even then, age should only be mentioned when it provides the only practical 'market of risk or benefit. NICE values people, equally, at all ages'.

But Steve Webb, the Liberal Democrat health spokesman, said there was a danger of primary care trusts following the same course of action. 'There is no excuse for cash-strapped hospitals denying treatment to people whose lifestyle they disapprove of, he said. 'Treatment decisions involving people's lifestyle should be based on clinical reasons, not grounds of cost. The NHS is there to keep people healthy, not to sit in judgement on individual lifestyles.

A spokesman for NICE said: 'We want to reassure people not in producing our guidance we are not going to take into consideration whether or not a particular condition was or is self inflicted. The only circumstance where that may be taken into account is where that treatment may be less effective because of lifestyle choices'.

Jonathan Ellis, the policy manager at Help the Aged, said it was pleased NICE had finally shown an understanding of the importance of tackling age discrimination. 'White this is a major feat there is still some way to go to banish the evident inherent age discrimination that exists within health care services,' he said. 'The NHS now has much to learn. It will ensure it fairer deal all round for older people using the NHS.'

#### Questions 14-16

Choose THREE letters A-H. NB Your answers may be given in any order.

Which THREE of the following statements are true of NICE, according to the text?

- A. It feels that people with bad health habit should not receive treatment.
- B. It is an agency that offers advice to the NHS.
- C. Some of the reports they produce discriminate against the elderly.
- D. It insists its decision should only be applicable in certain situations.
- E. It is an agency that controls all NHS policy regarding treatments.
- F. Its powers are not as extensive as those of the NBS.
- G. Many PCTs base their decisions concerning funding on one made by NICE.
- H. It has made a statement that overweight people will not receive new joints.

#### Questions 17-19

Choose the correct letter, A, B, C or D.

17. NICE argues that

- A. rich people should not be given special consideration over the poor.
- B. only patients from certain diseases should be considered for treatment.
- C. social roles should be considered when deciding treatment.
- D. cost of treatment would depend on patients' income.

18. What recommendations has NICE made?

- A. to provide older women with IVF treatment
- B. to make flu drugs accessible to women under 40
- C. to give people between 23-39 flu drugs
- D. to allow certain women to have IVF treatments

19. NICE admits that

- A. some drugs used by the NHS were not clinically effective.
- B. their advice is sometimes ignored by the NHS.
- C. it is often hard to determine if a patient has caused his or her condition.
- D. they are more concerned about cost effectiveness than patients.

#### Questions 20-26

Look at the following statements (Questions 20-26) and the list of people below, Match each statement with the correct person A-C.

20 This person was happy that NICE realised age discrimination needed dealing with.

21 This person holds a very high position in the NICE agency.

22 This person is a member of a political party.

23 This person says their policy regarding age is precise and easy to understand.

24 This person does not agree with the position taken by NICE.

25 This person feels the NHS must further improve its relations with the elderly.

26 This person says that NICE does not discriminate on the grounds of age.

<p>A Michael Rawlins B Steve Webb C Jonathan Ellis</p>
--

READING PASSAGE 3**The Romantic Poets**

One of the most evocative eras in the history of poetry must surely be that of the Romantic Movement. During the late eighteenth and early nineteenth centuries a group of poets created a new mood in literary casting off their predecessors' styles in favour of a gripping and forceful art which endures with us to this day.

Five poets emerged as the main constituents of this movement - William Wordsworth, Samuel Taylor Coleridge, George Gordon Byron, Percy Bysshe Shelley and John Keats. The strength of their works lies undoubtedly in the power of their imagination. Indeed, imagination was the most critical attribute of the Romantic poets. Each poet had the ability to portray remarkable images and visions, although differing to a certain degree in their intensity and presentation. Nature, mythology and emotion were of great importance and were used to explore the feelings of the poet himself.

The lives of the poets often overlapped and tragedy was typical in most of them. Byron was born in London in 1788. The family moved to Aberdeen soon after, where Byron was brought up until he inherited the family seat of Newstead Abbey in Nottinghamshire from his great uncle. He graduated from Cambridge University in 1808 and left England the following year to embark on a tour of the Mediterranean. During this tour he developed a passion for Greece which would later lead to his death in 1824. He left for Switzerland in 1816 where he was introduced to Shelley.

Shelley was born to a wealthy family in 1792. He was educated at Eton and then went on to Oxford. Shelley was not happy in England, where his colourful lifestyle and unorthodox beliefs made him unpopular with the establishment. In 1818 he left for Italy, where he was reunited with Byron. However, the friendship was tragically brought to an end in July 1819, when Shelley was drowned in a boating accident off the Italian coast. In somewhat dramatic form, Shelley's body was cremated on the beach, witnessed by a small group of friends, including Byron.

Historically, Shelley and Byron are considered to have been the most outspoken and radical of the Romantic poets. By contrast, Wordsworth appears to have been of a pleasant and acceptable personality, even receiving the status of Poet laureate in 1843. He was born in 1770 in Cockermouth, Cumbria. By the time he entered his early teens, both his parents had died. As he grew older, Wordsworth developed a passion for writing.

In 1798 Wordsworth published a collection of poems with Coleridge, whom he had met, a few years earlier, when he settled in Somerset with his sister Dorothy. He married in 1802 and as time passed he deserted his former political views and became increasingly acceptable to popular society. Indeed, at the time of his death in the spring of 1850, he had become one of the most sought-after poets of his time.

Wordsworth shared some of the years at DOVE Cottage in Somerset with his friend and poetical contemporary, Coleridge. Coleridge was born in Devon in 1772. He was a bright young scholar but never achieved the same prolific output of his fellow Romantic poets. In 1804 he left for a position in Malta for three years. On his return he separated from his wife and went to live with the Wordsworths, where he produced a regular periodical.

With failing health he later moved to London. In 1816 he went to stay with a doctor and his family. He remained with them until his death in 1834. During the latter years, his poetry was abandoned for other forms of writing equally outstanding in their own right.

Perhaps the most tragic of the Romantic poets was Keats. Keats was born in London in 1795. Similar to Wordsworth, both his parents had died by his early teens. He studied as a surgeon, qualifying in 1816. However poetry was his great passion and he decided to devote himself to writing. For much of his adult life Keats was in poor health and fell gravely ill in early 1820. He knew he was dying and in the September of that year he left for Rome hoping that the more agreeable climate might ease his suffering. Keats died of consumption in February 1821 at the age of twenty five.

It is sad that such tragedy often accompanies those of outstanding artistic genius. We can only wonder at the possible outcome had they all lived to an old age. Perhaps even Byron and Shelley would have mellowed with the years, like Wordsworth. However, the contribution to poetry by all five writers is immeasurable. They introduced the concepts of individualism and imagination, allowing us to explore our own visions of beauty without retribution. We are not now required to restrain our thoughts and poetry to that of the socially acceptable.

**Questions 27-32**

Do the following statements agree with the information given in Reading Passage 3? Write

- TRUE if the statement agrees with the information
- FALSE if the statement contradicts the information
- NOT GIVEN if there is no information on this

- 27. The Romantic Movement lasted for more than a century.
- 28. The Romantic poets adopted a style dissimilar to that of poets who had come before them.
- 29. Unfortunately, the works of the Romantics had no lasting impression on it.
- 30. The Romantics had no respect for any style of poetry apart from their own.
- 31. The Romantics were gifted with a strong sense of imagination.
- 32. Much of the Romantics' poetry was inspired by the natural world.

**Questions 33-39 Complete the table below.**

Write NO MORE THAN THREE WORDS for each answer.

	Date of birth	Education	
Byron	1788	Cambridge University	went on a journey around 33.....; came to love 34.....
Shelley	1792	Eton and Oxford University	some people disapproved of 35.....and the beliefs he held
Wordsworth	1770		became more accepted when he changed his 36.....
Coleridge	1772	bright scholar	his 37.....was smaller than the other Romantic poets'; left the Wordsworths due to 38.....
Keats	1795	qualified as a surgeon	left England for a change of 39.....

**Question 40**

Complete the sentence. Choose NO MORE THAN THREE WORDS from the passage for the answer

- 40. According to the writer, the Romantic poet left us with the ideas of .....



IELTS INTENSIVE READING 2  
READING PASSAGE 1

## The Rise and Fall of the British Textile Industry

Textile production in Britain can be said to have its roots as an industry at the beginning of the 18<sup>th</sup> century, when Thomas Crotchet and George Sorocold established what is thought to be the first factory built in Britain. It was a textile mill with a waterwheel as its source of power, the latest machinery, and even accommodation for the workers. As well as possibly being the first sweatshop in the modern sense, it was the beginning of the end for traditional textile production.

For hundreds of years the spinning and weaving of cloth had been done manually by men, women and children in their own homes. The yarn would be combed and spun using a spindle, then woven on a hand-loom, and what they produced would be mainly for local consumption. Technology far more sophisticated than the spindle and hand-loom would change all that.

The demand for cotton textiles had been growing since the Middle Ages, fostered by the importation of high quality cotton fabrics from the Middle East and India. So how were local producers to fight off the competition? The imported fabrics were of course expensive, so textile makers (not just in Britain but throughout Europe) produced mixed fabrics and cotton substitutes. They also had foreign textiles banned. But the key to the increased productivity needed to meet the demand, was machine production. It would be faster cheaper and the finished products would be consistent in quality. Not least of the advantages was that it would allow manufacturers to market their goods on a large, if not yet global, scale.

The story of the growth of the British textile industry from about 1733 and for the next two hundred years is one of constant technological innovation and expansion. In 1733 John Kay invented the fly-shuttle, which made the hand-loom more efficient, and in 1764 James Hargreaves came up with the spinning jenny, which among other things had the effect of raising productivity eight fold. The next great innovator was Richard Arkwright, who in 1768 employed John Kay (of the fly-shuttle) to help him build more efficient machinery. He was a man with a vision - to mechanise textile production - and by 1782 he had a network of mills across Britain. As the water-powered machinery, though not yet fully mechanised, became more complex, Kay began to use steam engines for power. The first power-loom, however, which was invented in 1785 by Dr Edmund Cartwright, really did mechanise the weaving stage of textile manufacture.

The pace of growth quickened with the expansion of Britain's influence in the world and the acquisition of colonies from which cheap raw materials could be imported. For example, in a single decade, from 1781 to 1791, imports of cotton into Britain quadrupled, going on to reach 100 million pounds in weight in 1815 and 263 million in 1830. The increase in exports is equally impressive; in 1751 £46,000 worth of cloth was exported and by the end of the century this had risen to £5.4 million. By the end of the 19<sup>th</sup> century the figure had soared to close on £50 million. Britain was now supplying cheaper and better quality clothing to a global market. Yet during the course of the 20<sup>th</sup> century Britain lost its position as a major textile manufacturer.

So what happened? There are a number of views on this question, not all of them conflicting, and where there is disagreement it is usually about when the decline began. Whether it began before the First World War (1914-18), or during the inter-war years (1919-1939), or after 1945, most economists would give roughly the same reasons. To start with, there was competition from abroad, especially from developing countries in the Far East, notably Japan. It was thought by manufacturers that the best way to combat this increased competition was to modernise. However, management and the labour unions were unable to agree on how to handle this situation.

Modernisation would mean people losing their jobs and possibly a change in labour practices. Such changes as were made served only to slow down the industries decline rather than help regain its predominant position. Economically less developed countries, on the other hand, had

the advantage of being able to provide low wage competition, without the problem of powerful labour unions.

There are, of course, many other reasons for the textile industry's decline, two of which became particularly noticeable in the late twentieth century and are related. The first is out-sourcing, when manufacturers establish factories in countries where there is cheap labour. This obviously leads to less demand for locally-produced goods. Related to this, the textile and clothing industries have acquired a bad reputation for exploiting workers, often illegal immigrants, in sweatshops where they are forced to work long hours and are paid far less than the minimum wage.

We seem to be back with Crotchet and Sorocold and their first live-in factory. The globalizing trend of out-sourcing, however was a rational response to the growing competition from overseas, which, it goes without saying, does not excuse the exploitation of workers. The British industry itself while no longer holding a key place in the global textile market has adapted itself and now concentrates more on the world of fashion and design, where it seems to be doing quite well.

### Questions 1-6

Complete the notes below. Write NO MORE THAN THREE WORDS for each answer.

#### Textile Manufacture

##### Early history

- Begins as a cottage industry
- Products hand-woven and made for 1.....
- Local producers face 2..... from overseas
- Ways found to deal with situations
- Imported fabrics 3....., mixed cottons produced

##### Early technology

- Machine production needed to 4 .....for cotton fabrics
- Improved technology (such as the fly-shuttle) more 5.....and productive
- Machinery begins to be powered by 6.....

### Questions 7-9

Choose the correct letter, A, B, C or D.

7. Which of the following innovations increased productivity by 800%
  - A. the power-loom
  - B. the steam engine
  - C. the spinning jenny
  - D. the f]y
8. During which period was the British textile industry at its peak?
  - A. 1733- 1785
  - B. 1781 – 1791
  - C. 1791 – 1830
  - D. 1830- 1900
9. Which of the following was a major cause of the British textile industry's decline?
  - A. the expansion of foreign textile industries
  - B. the loss of overseas markets
  - C. there being no demand for products
  - D. labour becoming too expensive

### Questions 10- 13

Do the following statements agree with the information given in Reading Passage 1? Write

True if the statement agrees with the information  
 False if the statement contradicts the information  
 Not given if there is no information on this

10. Foreign textiles were banned because of their inferior quality.
11. Richard Arkwright built the first fully-mechanised textile mill.
12. In less developed countries, the industry could rely on cheap labour.
13. Out-sourcing was one method used to compete with foreign manufacturers.

READING PASSAGE 2What is an ASBO?

Ask somebody to make a list of crimes and they will probably come up with the usual suspects that you or I would: murder, robbery, assault, burglary and so on. They might even include acts which are merely against the law, like parking on a double yellow line. But if you ask them to make a list of antisocial behaviours, you are getting into an area where there is going to be considerable disagreement. This didn't stop the UK government, which introduced Anti-Social Behaviour Orders, or ASBOs, in 1998 as part of the Crime and Disorder Act - legislation designed to deal with practically all aspects of criminal activity and disorderly behaviour.

A subjective definition of anti-social behaviour permits you to cast your net wide and include anything you find personally disagreeable; the legal definition is also widely inclusive. To quote the Crime and Disorder Act, it is behaviour which causes or is likely to cause harassment, alarm or distress to one or more people who are not in the same household as the perpetrator. This includes, among many other things, foul and abusive language, threatening behaviour, shouting, disorderly conduct, vandalism, intimidation, behaviour as the result of drug or alcohol misuse, graffiti and noise which is excessive, particularly at night.

The idea is that ASBOs are sanctions designed to deal with issues that affect everyone in the community and as such are civil sanctions, not criminal ones, and need the co-operation of the community to be effective. For example, a private individual cannot apply for an ASBO; he or she must make a complaint to the police or local authority, who will then work together to gather more information and build up evidence. This involves getting witnesses, among whom will no doubt be neighbours and acquaintances, to make statements to the authorities. When the authorities are satisfied that they have enough evidence, the local council applies to the magistrates court to have an ASBO imposed.

We still haven't decided what constitutes anti-social behaviour. It doesn't have to be physical violence, of course, but is far easier to identify and deal with if it is. What about threatening behaviour? We're not talking here about direct threats such as if you come round here again, I'll beat you up, but situations perceived as threatening. Let's say a pensioner or a person of timid disposition is on their way home and they run into a group of young people who are shouting, swearing and kicking a ball about and who happen to make a few unkind remarks as the person passes. Let's say the person is alarmed or feels threatened by the situation. Does it merit getting the ASBO process going?

In fact, young people merely hanging out in public places, however boisterous their behaviour might seem to be to some people, are not considered to be indulging in anti-social behaviour. However, there is a proviso. Such behaviour in its own right is not considered anti-social unless it is thought it is being done with other more serious, behavioural attitudes involved. This, of course, can be very subjective.

A person faced with an ASBO can argue in their defence that their behaviour was reasonable and unthreatening. This too is subjective, and both sides' claims are open to wide interpretation. Something else that has to be taken into account here is that ASBOs are made on an individual basis even if that person is part of a group of people committing anti-social behaviour. If a case reaches the magistrates' court, witnesses can be called to provide further evidence for or against the defendant. However, the magistrate, as well as considering the complaints made against the defendant, will take into account his or her family situation, welfare issues, and whether or not he or she has been victimised or discriminated against. It is worth bearing in mind, though, that witnesses can be intimidated or otherwise persuaded not to appear in court and give evidence.

When the Crime and Disorder Act came into force, ASBOs were generally intended to be a measure to deal with adult anti-social behaviour, yet within the Act it states that an order can be applied for against any individual over the age of ten years old. It is a striking fact that the majority

of ASBOs imposed since the law was enacted have been handed out to young people and children.

The question is, have they been effective? The government naturally, claims that they have brought about a real improvement in the quality of life in communities around the country. Nay-Sayers, such as civil rights campaigners, claim the measures are far too open to abuse. Some say they go too far and some that they don't go far enough and lack bite. However, a genuine impediment to their effectiveness is that to impose an ASBO takes a lot of time and paperwork, involving the cooperation of community, police and local council and they are very expensive to implement. One estimate is that an ASBO can cost in excess of £20,000. What all this means is that ASBOs are being used very rarely in many parts of the country. So the jury is still out as to how effective they really are.

#### Questions 14-16

Choose THREE letters A-H. NB Your answers may be given in any order.

Which THREE of the following statements are true of ASBOs, according to the text?

- A. They were introduced to deal with specific crimes.
- B. Parking on a double yellow line could get you served with an ASBO.
- C. Swearing is one of the offences referred to in the Crime and Disorder Act.
- D. As a private householder you can apply for an ASBO against a noisy neighbour.
- E. It is not illegal for young people to gather in groups in public places.
- F. An ASBO cannot be served on a group of people behaving in a disorderly manner.
- G. A large proportion of those served with ASBOs are over the age of 21.
- H. Most people agree that ASBOs have been effective all over the country.

#### Questions 17-19

Choose the correct letter, A, B, C or D.

17. The writer suggests that
- A. anti-social behaviour should be seen as a crime.
  - B. Few people agree on how to define a crime.
  - C. anti-social behaviour is difficult to define.
  - D. the legal definition of crime is too exclusive.
18. What surprised the writer about the imposition of ASBOs?
- A. the number of ten-year olds that had been given one
  - B. that very few adults had been served with ASBOs
  - C. that most of those served with ASBOs were youngsters
  - D. how few ASBOs had been imposed since 1998
19. In the writer's opinion, how effective have ASBOs been?
- A. There isn't enough evidence to decide.
  - B. They are too expensive to be effective.
  - C. They are ineffective because they are not strict enough.
  - D. Being open no abuse renders them ineffective.

#### Questions 20-26

Complete the sentences. Choose NO MORE THAN THREE WORDS from the passage for each answer.

20. The official .....says that antisocial behaviour is behaviour which can cause alarm or distress.
21. Along with swearing and destruction of public or private property, making .....noise is considered anti-social behaviour.
22. ASBOs are considered to be part of .....law rather than criminal law.
23. Citizens have to .....to either the local council or the police before any action can be taken.
24. In their efforts to collect evidence the authorities may call on .....to get more information.
25. ASBOs are issued at a.....
26. .... is the most straightforward form of anti-social behaviour to determine.

**READING PASSAGE 3****The Climate Changers**

The romantic notion that early humans lived in harmony with their environment has taken quite a battering lately. Modern humans may have started eliminating other species right from the start: our ancestors stand accused of wiping out mega fauna - from giant flightless birds in Australia to mammoths in Asia and the ground sloth of North America - as they spread across the planet.

Even so, by around 6,000 years ago there were only about 12 million people on earth – less than a quarter of the current population of Great Britain. That's a far cry from today's 6.6 billion, many of us guzzling fossil fuels, churning out greenhouse gases and messing with our planet's climate like there's no tomorrow. So it may seem far-fetched to suggest that humans have been causing global warming ever since our ancestors started burning and cutting forests to make way for fields at least 7,000 years ago.

Yet that's the view of retired climate scientist William Ruddiman, formerly of the University of Virginia, Charlottesville. Ancient farmers were pumping climate warming carbon dioxide and methane into the atmosphere long before recorded history began, he says. Far from causing catastrophe, however early farmers halted the planet's descent into another ice age and kept Earth warm and stable for thousands of years.

Could a few primitive farmers really have changed the climate of the entire globe? If you found this hard to believe, you're not the only one. Ruddiman's idea has been hugely controversial ever since he proposed it in 2003. Most new ideas, especially controversial ones, die out pretty fast. It doesn't take science long to weed them out, he says. Yet five years on, his idea is still not dead. On the contrary, he says the latest evidence strengthens his case. 'It has become clear that natural explanations for the rise in greenhouse gases over the past few thousand years are the ones that are not measuring up, and we can reject them,' he claims. There is no doubt that the soaring levels of carbon dioxide and other greenhouse gases that we see in the atmosphere today - causing a 0.7° C rise in average global temperature during the 20<sup>th</sup> century - are the result of human activities. In the late 1990s, however, Ruddiman started to suspect that our control button to the global greenhouse began to become significant long before the Industrial age began. This was when an ice core drilled at the Vostok station in Antarctica revealed how atmospheric CO<sub>2</sub> and methane levels have changed over the past 400,000 years. Bubbles trapped in the ice provide a record of the ancient atmosphere during the past three interglacials.

What we see is a regular pattern of rises and falls with a period of about 100,000 years, coinciding with the coming and going of ice ages. There are good explanations for these cycles: periodic changes in the planet's orbit and axis of rotation alter the amount of sunlight reaching the Earth. We are now in one of the relatively brief warm interglacial periods that follow an ice age.

Within this larger pattern there are regular peaks in methane every 22,000 years that coincide with the times when the Earth's orbit makes summers in the northern hemisphere warmest. This makes sense, because warm northern summers drive strong tropical monsoon in southern Asia that both encourage the growth of vegetation and cause flooding, during which vegetation rotting in oxygen-poor water will emit methane. Around the Arctic, hot summers thaw wetlands for longer, again promoting both vegetation growth and methane emission.

In recent times, however, this regular pattern has changed. The last methane peak occurred around 11,000 years ago, at about 700 parts per billion (ppb), after which levels began to fall. But instead of continuing to fall to what Ruddiman says should have been a minimum of about 450 ppb today, the atmospheric methane began to climb again 5,000 years ago.

Working with climate modellers Stephen Verves and John Kutzbach, Ruddiman has shown that if the levels of these gases had continued to fall rather than rising when they did, ice sheets would

now cover swathes of northern Canada and Siberia. The world would be heading into another ice age.

So why did both methane and CO<sub>2</sub> rise over the past few thousand years? In other words, why has this Interglacial period been different from previous ones? Could humans be to blame?

Agriculture emerged around the eastern Mediterranean some 11,000 years ago, then shortly afterwards in China and several thousand years later in the Americas. Farming can release greenhouse gases in various ways; clearing forests liberates lots of stored carbon as the wood rots or is burned, for instance, while flooded rice paddles release methane just as wetlands do.

To find out more about early farming, Ruddiman began to dig around in studies of agricultural history. These revealed that there was a sharp rise in rice cultivation in Asia around 5,000 years ago, with the practice spreading across China and south-east Asia. Here at least was a possible source for the unexpected methane rise.

#### Questions 27-29

Choose the correct letter, A, B, C or D

27. One of the claims Ruddiman makes is that
  - A. population growth is responsible for global warming.
  - B. people have affected the climate for thousands of years.
  - C. his ideas are not in the least bit controversial.
  - D. so far scientists have been wrong about global warming.
28. What information did the research at Vostok reveal for the first time?
  - A. that methane levels stabilised about 11,000 years ago
  - B. that Antarctic ice contains methane bubbles
  - C. that the methane levels increased about 5,000 years ago
  - D. that we are now living in a warm interglacial period
29. The 'climate changers' of the title are
  - A. modern humans
  - B. climate modellers
  - C. primitive farmers
  - D. natural causes

#### Questions 30-34

Complete the summary. Choose NO MORE THAN TWO WORDS from the passage for each answer.

To many people the controversial idea that our 30..... were responsible for global warming appears 31..... Yet Ruddiman believes that high levels of carbon dioxide and methane - both 32 ....., or greenhouse, gases - were being released into the Earth's atmosphere in times prior to 33..... However, Ruddiman claims that this had a positive effect, as it may well have saved us from another 34.....

#### Questions 35-40

Do the following statements agree with the information given in Reading Passage 3? Write

True: if the statement agrees with the information

False: if the statement contradicts the information

Not given: if there is no information on this

35. Some mega fauna have been eliminated by humans in the past 100 years.
36. Agriculture is considered a primary cause of global warming today.
37. Ruddiman's idea caused a great deal of argument among scientists.
38. New scientific evidence proves for certain that Ruddiman's theory is correct.
39. The 20<sup>th</sup> century has seen the greatest ever increase in global temperatures.
40. Changes in the Earth's orbit can affect global temperatures.

IELTS INTENSIVE TEST 3  
READING PASSAGE 1

## How Mobile Telephony Turned into a Health Scare

The technology which enabled mobile phones was previously used in the kind of two-way radio which could be found in taxis and emergency vehicles. Although this was a great development, it was not really considered mobile telephony because it could not be used to dial into existing phone networks. It was known as simplex technology, operating on the same principles as a walkie-talkie, which required that a user press a button, meaning that only one person at a time could talk. Simplex meant that there was only one communication frequency in use at any one time.

The first mobile phones to connect to telephone networks were often installed in cars before the hand-held version came on the market and the revolution in mobile technology began. The first generation of mobile phones (called 1G) were large, heavy and analogue and it was not until the invention of the second generation (2G) in the 1990s that digital networks could be used the digital element enabled faster signaling. At the same time, developments in battery design and energy-saving electronics allowed the phones themselves to become smaller and therefore more truly mobile. The second generation allowed for text messaging too, and this began with the first person-to-person text message in Finland in 1993, although a machine-generated text message had been successfully sent two years earlier.

None of this would have been possible without the development of duplex technology to replace the relatively primitive simplex technology of the first phase of mobile communication. In duplex technology, there are two frequencies available simultaneously. These two frequencies can be obtained by the principle of Frequency Division Duplex (FDD). To send two signals wirelessly; it is necessary to create a paired spectrum, where one band carries the uplink (from phone to antenna) and the other carries the downlink (from antenna to phone). Time Division Duplex (TDD) can achieve the same thing, but instead of splitting the frequency, the uplink and downlink are switched very rapidly, giving the impression that one frequency is used.

For mobile telephony to work to its fullest potential, it needs to have a network through which it can relay signals. This network depends on base stations which send and receive the signals. The base stations tend to be simple constructions, or masts, on top of which are mounted the antennas, with the rapid increase in demand for mobile services. The infrastructure of antennas in the United Kingdom is now huge.

Many thousands of reports have appeared claiming that the signals relayed by these antennas are harmful to human and animal health. The claims focus on the fact that the antennas are transmitting radio waves in microwave form. In some ways, public demand is responsible for the increase in the alleged threat to health. Until quite recently, voice and text messages were transmitted using 2G technology. A 2G mast can send a low-frequency microwave signal approximately 35 kilometres. Third generation (3G) technology allows users to wirelessly download information from the internet and is extremely popular. The difference is that 3G technology uses a higher frequency to carry the signals, allowing masts to emit more radiation. This problem is intensified by the need to have masts in closer proximity to each other and to the handsets themselves. Whatever danger there was in 2G signals is greatly multiplied by the fact that the 3G masts are physically much closer to people.

Government authorities have so far refused to accept that there is a danger to public health, and tests carried out by governments and telecommunications companies have been restricted to testing to see if heat is being produced from these microwaves. According to many, however the problem is not heat, but electromagnetic waves which are found near the masts.

It is believed that some people, though not all, have a condition known as electro-sensitivity or electro-hypersensitivity (EHS), meaning that the electromagnetism makes them ill in some way. The actual health threat from these pulsed microwave signals is an area which greatly needs more

research. It has been claimed that the signals affect all living organisms, including plants, at a cellular level and cause symptoms in people ranging from tiredness and headaches to cancer. Of particular concern is the effect that increased electromagnetic fields may have on children and the fear is that the negative effects on their health may not manifest themselves until they have had many years of continued exposure to high levels. Tests carried out on animals living close to this form of radiation are particularly useful because scientists can rule out the psychological effect that humans might be exhibiting due to their fear of possible contamination.

Of course, the danger of exposure exists when using a mobile phone but since we do this for limited periods, between which it is believed our bodies can recover, it is not considered as serious as the effect of living or working near a mast (sometimes mounted on the very building we occupy) which is transmitting electromagnetic waves 24 hours a day.

#### Questions 1-6

Answer the questions below. Write **NO MORE THAN THREE WORDS** for each answer.

1. What were early two-way radios unable to use?
2. What did you have to do in order to talk on a radio using simplex technology?
3. Where were early mobile phones generally used?
4. What development introduced digital technology into mobile telephony?
5. Apart from the area of electronics, in which area did developments help make phones more mobile?
6. What type of text message was the first one ever sent?

#### Questions 8-10

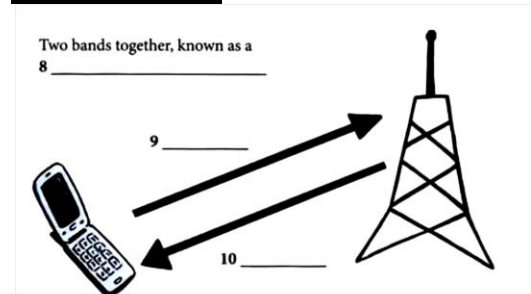

#### Questions 11 -13

Choose the correct letter. A, B, C or D.

11. 3G technology is believed to be more of a threat to health because
  - A. the signals are transmitted over much greater distances than before.
  - B. the masts are closer together and emit higher frequencies.
  - C. the signals are carrying both voice and text messages.
  - D. the modern handsets needed emit more radiation.
12. Why might the testing of animals give us more reliable results?
  - A. because most of them live closer to the masts
  - B. because they are continually exposed to higher levels of radiation
  - C. because they are not affected at a cellular level
  - D. because they are not afraid of the effects of radiation
13. What is believed to limit the danger from mobile phones?
  - A. not using them continuously
  - B. turning them off when not in use
  - C. mounting a mast on the building where you live or work
  - D. keeping healthy and getting enough sleep



**READING PASSAGE 2****Some Facts and Theories about Flu**

The flu, more properly known as influenza, takes its name from the fact that it is so easily transmitted from person to person (influenza is the Italian word for 'influence'). Usually contamination occurs through direct contact with secretions from an infected person. Its spread is also possible from contaminated air borne particles, such as those that occur when someone coughs or sneezes. However, it should be made clear that the risk is not great from simply being in the same room as an infected person, since the flu virus, unlike other respiratory viruses, does not dissolve in the air. Within 4-6 hours of someone catching the flu, the virus multiplies in infected cells and the cells burst, spreading the virus to other cells nearby.

The spread continues for up to 72 hours, the exact length of time depending on the body's immune system response and the strength of the particular strain of flu. The range of human responses to the flu virus has been of interest to scientists for many years. This is because the effect can vary from no infection to a rapid and deadly spread of the virus to many people. One area of study that has received particular attention is the immune system response of the individual. Where a person's immune system is healthy, the virus is attacked as it enters the body, usually in the respiratory tract. This lessens the severity of the illness. In contrast, people with compromised immune systems (typical in the young, where it is not fully developed, or in the old and the sick, where it is not working efficiently), often suffer the worst effects.

One of the body's responses to flu is the creation of antibodies which recognise and destroy that particular strain of flu virus. What fascinates most researchers in the field is that the human body seems capable of storing these antibodies over a whole lifetime in case of future attack from the same or similar strains of flu. It was while researching these antibodies that scientists turned their attention back to what was possibly the worst ever flu pandemic in the world. The actual number of deaths is disputed, but the outbreak in 1918 killed between 20 and 50 million people. It is also estimated that one fifth of the population of the world may have been infected.

Through tests done on some of the survivors of the 1918 outbreak, it was discovered that 90 years later, they still possessed the antibodies to that strain of flu, and some of them were actually still producing the antibodies. Work is now focused on why these people survived in the first place. With one theory being that they had actually been exposed to an earlier, similar strain, therefore developing immunity to the 1918 strain. It is hoped that, in the near future, we might be able to isolate the antibodies and use them to vaccinate people against further outbreaks.

Yet vaccination against the flu is an imprecise measure. At best, the vaccine protects us from the variations of flu that doctors expect that year. If their predictions are wrong in any particular year, being vaccinated will not prevent us from becoming infected. This is further complicated by the fact that there are two main types of flu, known as influenza A and influenza B. Influenza B causes less concern as its effects are usually less serious. Influenza A, however, has the power to change its genetic makeup. Although these genetic changes are rare, they create entirely new strains of flu against which we have no protection. It has been suggested that this is what had happened immediately prior to the 1918 outbreak, with research indicating that a genetic shift had taken place in China.

In 2005, another genetic shift in an influenza A virus was recorded, giving rise to the H5N1 strain, otherwise known as avian flu, or bird flu. Typical of such new strains, we have no way of fighting it and many people who are infected with it die. Perhaps more worrying is that it is a strain only previously found in birds but which changed its genetic make-up in a way that allowed it to be transmitted to humans. Most of the fear surrounding this virus is that it will change again, developing the ability to pass from human to human. If that change does happen, scientists and doctors can reasonably expect a death rate comparable to that which occurred in 1918 and, given that we can now travel more quickly and more easily between countries, infecting many more people than was previously possible, it could be several times worse.

#### Questions 14-20

Do the following statements agree with the information given in Reading Passage. Write

True: if the statement agrees with the information

False: if the statement contradicts the information

Not Given: if there is no information on this

14. The only way to catch flu is if someone coughs or sneezes near you.
15. You become aware of the symptoms of flu within 4-6 hours of infection.
16. The effect of a flu infection can depend on how strong the strain is.
17. Those who are more likely to suffer badly with the flu include very young or very old people.
18. Although antibodies last a lifetime, scientists have found they get weaker with age.
19. Vaccination is largely ineffective against flu.
20. Another change in the genetic make-up of the H5N1 strain could kill more people than the 1918 epidemic.

#### Questions 21 -24

Classify the following statements as characterising

- A. something known by scientists to be true
- B. something believed by scientists to be true
- C. something known by scientists to be false

Write the correct letter, A, B or C.

21. Sharing a room with a flu sufferer presents a very high risk to your health.
22. One fifth of the people in the world caught the flu in 1918.
23. Influenza A viruses do not change their genetic make-up frequently
24. The H5N1 strain evolved in or before 2005.

#### Questions 25 and 26

Answer the questions below.

Write NO MORE THAN THREE WORDS for each answer.

25. In which part of the body do antibodies normally attack the flu virus?
26. What kind of transmission of the H5N1 strain are people afraid might become reality?

### READING PASSAGE 3

## Changes in International Commerce

### How ethics and fair trade can make a difference

The purpose of international commerce is to buy things from and sell things to people in other countries. Hundreds, and indeed thousands, of years ago, this actually worked quite well. People, who travelled to foreign lands, often by ship, would take with them items for trade. Agricultural countries would, for example, trade olive oil or wine for weapons or other worked items. All that needed to be negotiated was a fair 'price' for the items. (How many axes is a barrel of oil worth, for example?) Currency did not enter into the first deals but, even when it did, few problems existed to complicate matters barring disagreements over the value of goods.

Today, fixing a fair price remains at the centre of international commerce. When we look at the deal from the point of view of the seller, market research must determine the price at which the goods will be sold. This may vary greatly from country to country and people are often surprised to see exactly the same item for sale at two or three times the price it sells for in another country. Taxation and local government controls are sometimes behind this, but often it comes down to the fact that people in poor countries simply cannot afford to pay the same amount of money as those in rich countries. These are the things a seller has to bear in mind when preparing a price list for goods in each country.

In most cases, the purpose of setting a suitable price is to sell the maximum number of units. Usually, this is the way to guarantee the biggest profit. One exception is in the selling of luxury or specialist goods. These are often goods for which there is a limited market. Here, slightly different rules apply because the profit margin (the amount of money a producer makes on each item) is much higher. For instance, nearly everyone wants to own a television or a mobile phone, and there is a lot of competition in the area of production, forcing the prices to be competitive too. The producers have to sell a large number of items to make a profit because their profit margin is small. But not everyone wants to buy hand-made jewellery, or a machine for sticking labels onto bottles. This enables the producer to charge a price much higher than the cost of making the item, increasing the profit margin. But at the heart of any sale, whether they sell many items for a small profit, or a few items for a large profit, the prime motivation for the producer is to make as much profit as possible.

At least, that was the case until relatively recently when, to the great surprise of many, companies started trading without profit as their main objective. Ethical trade began as an attempt to cause as little damage as possible to the producers of raw materials and manufactured goods in poor countries. This movement put pressure on the industry to see to it that working conditions and human rights were not damaged by the need for poorer people to produce goods. In short, it drew to the world's attention the fact that many poor people were being exploited by big businesses in their drive to make more profit.

There have been many examples throughout the developing world where local producers were forced by economic pressure to supply cash crops such as tea, coffee and cotton to major industries. These people are frequently not in a position to fix their prices, and are often forced by market conditions to sell for a price too low to support the producers and their community. Worse still, while the agricultural land is given over to cash crops, it robs the local people of the ability to grow their own food. In time, through over-production, the land becomes spent and infertile, leading to poverty, starvation, and sometimes the destruction of the whole community.

Fair trade policies differ from ethical trade policies in that they take the process a stage further. Where ethical policies are designed to keep the damage to a minimum, fair trade organisations actually work to improve conditions among producers and their communities. Fair trade organisations view sustainability as a key aim. This involves implementing policies where producers are given a fair price for the goods they sell, so that they and their communities can continue to operate.

Although many big businesses are cynical about an operation that does not regard profit as a main driving force, the paradox is that it will help them too. With sustainability as their main aim, fair trade organisations not only help the poorer producers obtain a reasonable standard of living, but they also help guarantee a constant supply of raw materials. This form of sustainability benefits everyone, whether their motive is making a profit or improving the lives of the world's poorer people.

**Questions 27-31**

Classify the following as being a result of

- A. fair trade policies
- B. ethical trade policies
- C. a country being poor

Write the correct letter, A, B or C.

- 27. Manufactured goods are obtainable at a lower price than elsewhere.
- 28. Harm to producers of raw materials is minimised.
- 29. Human rights are respected.
- 30. Land is not used to produce food for the local population.
- 31. The local community has more chance of survival.

**Questions 32-36**

Complete the flow chart below. Use NO MORE THAN THREE WORDS from the passage for each answer.

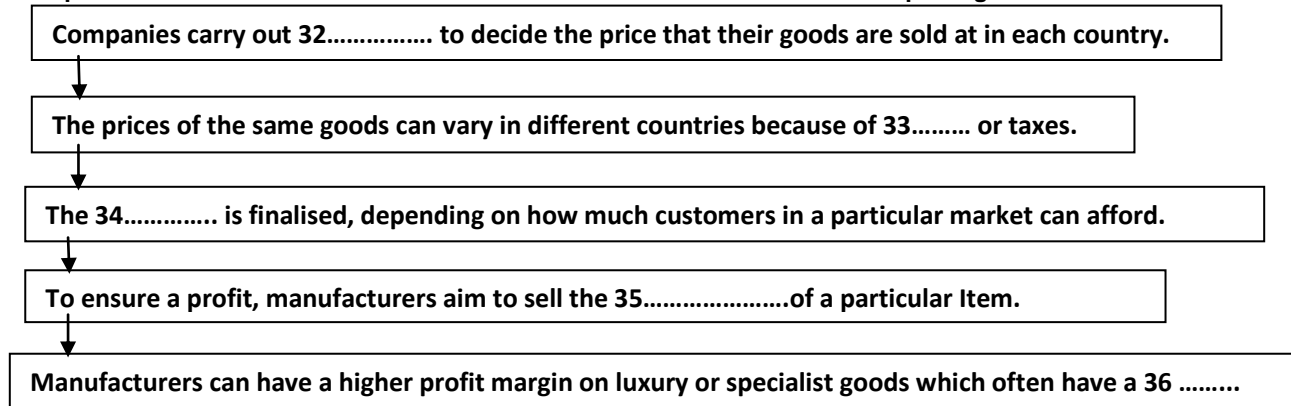
**Questions 37-40**

Choose the correct letter, A, B, C or D.

- 37. According to the writer, what might early traders have disagreed about?
  - A. the comparative values of the goods
  - B. which currency to use for their deal
  - C. which items they wanted as exchange
  - D. the quality of the goods being traded
- 38. What is the main consequence of a product being in demand?
  - A. higher prices
  - B. smaller profit margins
  - C. fewer items being produced
  - D. less market competition
- 39. How might an agricultural community be destroyed?
  - A. because companies in richer countries steal from them
  - B. because they ask an unrealistically high price for their produce
  - C. because they over-use the land in order to grow cash crops
  - D. because the crops take much too long to grow
- 40. The word paradox in the final paragraph refers to the fact that
  - A. poorer people will become richer than the people who run big businesses.
  - B. by being cynical. the big businesses have helped produce a result they do not want.
  - C. the suppliers of raw materials will sell them to big businesses for a huge profit.
  - D. big businesses will gain from these policies although they don't support them.

IELTS INTENSIVE READING 4  
READING PASSAGE 1

## **Prehistoric Cave Paintings Took up to 20,000 Years to Complete**

It may have taken Michelangelo four long years to paint his fresco on the ceiling of the Sistine Chapel, but his earliest predecessors spent considerably longer perfecting their own masterpieces. Scientists have discovered that prehistoric cave paintings took up to 20,000 years to complete. Rather than being created in one session, as archaeologists previously thought, many of the works discovered across Europe were produced over hundreds of generations, who added to, refreshed and painted over the original pieces of art.

Until now it has been extremely difficult to pinpoint when prehistoric cave paintings and carvings were created, but a pioneering technique is allowing researchers to date cave art accurately for the first time and show how the works were crafted over thousands of years. Experts now hope the technique will provide a valuable insight into how early human culture developed and changed as the first modern humans moved across Europe around 40,000 years ago.

Dr Alistair Pike, an archaeologist at Bristol University who is leading the research, said: 'The art gives us a really intimate window into the minds of the individuals who produced it, but what we don't know is exactly which individuals they were as we don't know exactly when the art was created. If we can date the art then we can relate that to the artefacts we find in the ground and start to link the symbolic thoughts of these individuals to where, when and how they were living.'

Hundreds of caves have been discovered across Europe with elaborate prehistoric paintings and carvings on their walls. It is thought the designs, which often depict scenes of animals, were created up to 40,000 years ago - sometime after humans began moving from southern Europe into northern Europe during the last ice age.

Traditional dating techniques have relied on carbon dating the charcoal and other pigment used in the paintings, but this can be inaccurate as it only gives the date the charcoal was created not when the work was crafted. 'When you go into these caves today there is still charcoal lying on the ground, so the artists at the time could have been using old charcoal rather than making it fresh themselves', explained Dr Pike.

'If this was the case, then the date for the painting would be very wrong. Taking samples for carbon dating also means destroying a bit of these precious paintings because you need to take away a bit of the pigment. For carvings, it is virtually impossible to date them as there is no organic pigment containing carbon at all.'

The scientists have used their technique to date a series of famous Paleolithic paintings in Altamira cave, northern Spain, known as the 'Sistine Chapel of the Paleolithic,' the elaborate works were thought to date from around 14,000 years ago. But in research published by the Natural Environment Research Council's new website Planet Earth, Dr Pike discovered some of the paintings were between 25,000 and 35,000 years old. The youngest paintings in the cave were 11,000 years old. Dr Pike said: 'We have found that most of these caves were not painted in one go, but the painting spanned up to 20,000 years. This goes against what the archaeologists who excavated in the caves found. It is probably the case that people did not live in the caves they painted. It seems the caves they lived in were elsewhere and there was something special about the painted caves.'

Dr Pike and his team were able to date the paintings using a technique known as uranium series dating, which was originally developed by geologists to date rock formations such as stalactites and stalagmites in caves. As water seeps through a cave, it carries extremely low levels of dissolved radioactive uranium along with the mineral calcium carbonate. Over time small amounts

of calcium carbonate are deposited to form a hard layer over the paintings and this layer also traps the uranium. Due to its radioactive properties, the uranium slowly decays to become another element known as thorium. By comparing the ratio of uranium to thorium in the thin layers on top of the cave art, the researchers were able to calculate the age of the paintings.

The researchers have also applied their technique to engravings found in rocks around Creswell Crags in Derbyshire, which are Britain's only examples of ice age cave art. They proved the engravings were made at least 12,000 years ago. Professor Pablo Arias, an expert on Paleolithic cave art at the University of Cantabria, Spain, said: 'Until about ten years ago it was only possible to date cave art by using the style of the figures, but this new technique developed by Bristol University allows that date to be accurately bracketed, we want to study how the people of the time behaved and how they felt and Paleolithic art gives us a way of looking at the type of symbols that were important to them, so we need to know when the people who were making the art actually lived.'

#### **Questions 1-5**

Do the following statements agree with the information given in Reading Passage 1? Write

TRUE if the statement agrees with the information  
 FALSE if the statement contradicts the information  
 NOT GIVEN if there is no information on this

1. Cave paintings inspired Michelangelo to paint the ceiling of the Sistine Chapel
2. It now seems that cave paintings were painted in one go and then left untouched.
3. Dr Pike is focussing on dating artefacts found on the ground in the caves.
4. There are a number of disadvantages to using carbon dating to date paintings and carvings.
5. The Altamira cave contains more cave paintings than any other cave in Europe.

#### **Questions 6-8** Choose the correct letter, A, B, C or D.

6. Dr Pike believes that
  - A. most caves remained undiscovered for thousands of years.
  - B. archaeologists should not have excavated the caves at all.
  - C. the caves were uninhabited but were treated as important.
  - D. the paintings were painted by the people living in the caves.
7. Uranium series dating
  - A. was previously used for other purposes.
  - B. is a technique which was invented by Dr Pike.
  - C. relies on the presence of stalactites in the caves.
  - D. only works with caves which are underwater.
8. Professor Pablo Arias
  - A. is sceptical about the benefits of the new dating technique.
  - B. is enthusiastic about what the new technique will achieve.
  - C. used the technique to successfully date Creswell Crags.
  - D. believes it is necessary only to study the symbols in the art.

#### **Questions 9-14**

What is said about each of these things found in the caves? Write the letters A—H next to Question 9-14

- |   |
|---|
| <ol style="list-style-type: none"> <li>A. When this is removed, it damages the painting.</li> <li>B. This can damage the stalactites and stalagmites in the caves.</li> <li>C. Over time, this turns into a different element.</li> <li>D. We could determine when it was made, but not when it was used.</li> <li>E. This is produced as a result of radioactive decay.</li> <li>F. Scientists used to think that this was a mineral.</li> <li>G. This contains no carbon-based elements at all.</li> <li>H. This can act as a thin coating over something.</li> </ol> |
|---|

- |  |
|--|
| <ol style="list-style-type: none"> <li>9. Charcoal</li> <li>10. Pigment</li> <li>11. Carving</li> <li>12. Uranium</li> <li>13. calcium carbonate</li> <li>14. thorium</li> </ol> |
|--|

## READING PASSAGE 2

**Children Tested to Destruction?**

*English primary school pupils subjected to more tests than in any other country.*

English primary school pupils have to deal with unprecedented levels of pressure as they face tests more frequently, at a younger age, and in more subjects than children from any other country, according to one of the biggest international education inquiries in decades. The damning indictment of England's primary education system revealed that the country's children are now the most tested in the world. From their very earliest days at school they must navigate a set-up whose trademark is 'high stakes' testing, according to a recent report.

Parents are encouraged to choose schools for their children based on league tables of test scores. But this puts children under extreme pressure which could damage their motivation and self-esteem, as well as encouraging schools to 'teach to the test' at the expense of pupils' wider learning, the study found. The findings are part of a two-year inquiry - led by Cambridge University — into English primary schools. Other parts of the UK and countries such as France, Norway and Japan used testing but it was, 'less intrusive, less comprehensive, and considerably less frequent', Cambridge's Primary Review concluded.

England was unique in using testing to control what is taught in schools, to monitor teaching standards and to encourage parents to choose schools based on the results of the tests, according to Kathy Hall, from the National University of Ireland in Cork, and Kamil Ozerk, from the University of Oslo, who conducted the research. 'Assessment in England, compared to our other reviewed countries, is pervasive, highly consequential, and taken by officialdom and the public more generally to portray objectively the actual quality of primary education in schools,' their report concluded. Teachers' leaders said the testing regime was 'past its sell-by date' and called for a fundamental review of assessment.

Steve Sinnott, General Secretary of the National Union of Teachers, said England's testing system was having a 'devastating' impact on schools. Uniquely, England is a country where testing is used to police schools and control what is taught,' he said. 'When it comes to testing in England, the tail wags the dog. It is patently absurd that even the structure and content of education is shaped by the demands of the tests. I call on the Government to initiate a full and independent review of the impact of the current testing system on schools and on children's learning and to be prepared to dismantle a system which is long past its sell-by date'.

John Dunford, General Secretary of the Association of School and College Leaders, warned that the tests were having a damaging effect on pupils. 'The whole testing regime is governed by the need to produce league tables,' he said. 'It has more to do with holding schools to account than helping pupils to progress.'

The fear that many children were suffering intolerable stress because of the tests was voiced by Mick Brookes, General Secretary of the National Association of Head Teachers. 'There are schools that start rehearsing for key stage two SATs [Standard Assessment Tests] from the moment the children arrive in September. That's just utterly ridiculous,' he said. 'There are other schools that rehearse SATs during Christmas week. These are young children we are talking about. They should be having the time of their lives at school not just worrying about tests. It is the breadth and richness of the curriculum that suffers. The consequences for schools not reaching their targets are dire — heads can lose their jobs and schools can be closed down. With this at stake it's not surprising that schools let the tests take over.'

David Laws, the Liberal Democrat schools spokesman, said: 'The uniquely high stakes placed on national tests mean that many primary schools have become too exam focused.' However the Government rejected the criticism. 'The idea that children are over-tested is not a view that the Government accepts,' a spokesman said. 'The reality is that children spend a very small

percentage of their time in school being tested. Seeing that children leave school up to the right standard in the basics is the highest priority of the Government.

In another child-centred initiative, both major political parties in the UK — Labour and the Conservatives — have announced plans to make Britain more child-friendly following a report by UNICEF which ranked the UK the worst place to be a child out of 21 rich nations. Parents were warned that they risked creating a generation of 'battery-farmed children' by always keeping them indoors to ensure their safety. The family's minister, Kevin Brennan, called for an end to the 'cotton wool' culture and warned that children would not learn to cope with risks if they were never allowed to play outdoors.

**Questions 15-19** Complete the sentences.

Choose NO MORE THAN TWO WORDS from the passage for each answer.

15. According to the inquiry, the amount of testing puts a lot of .....on young children.
16. The education report describes testing in England as .....testing.
17. Parents often select their children's schools after studying test results in.....
18. Kathy Hall and Kamil Ozerk believe testing in England is also used to evaluate.....in schools.
19. The major political parties have promised to make Britain.....in view of the UNICEF report.

**Questions 20-23**

Do the following statements agree with the information given in Reading Passage. Write

- TRUE if the statement agrees with the information  
 FALSE if the statement contradicts the information  
 NOT GIVEN if there is no information on this

20. Steve Sinnott says what is taught at school should be more tightly controlled
21. According to John Dunford, children would make more progress with much shorter and easier tests.
22. Mick Brookes wants to see earlier student preparation for SATs.
23. David Laws agrees with the opinions of Mick Brookes.

**Questions 24-27**

Choose the correct letter, A, B, C or D.

24. What does the government argue?
  - A. There is not enough testing at present.
  - B. Tests at primary school are too easy.
  - C. Tests are not given too frequently.
  - D. Teachers should take more tests
25. The government spokesman
  - A. is extremely critical of the way exams are written.
  - B. accepts many of the points made by the teachers' leaders.
  - C. thinks education is what the government is most interested in,
  - D. argues it is the teachers' fault that students are tested so much.
26. According to UNICEF children in the UK
  - A. often spend too much time in the worst kind of places.
  - B. are not so well behaved as in other countries.
  - C. are not as rich as children in 21 other countries.
  - D. could be having much more fulfilling childhoods,
27. What is the point Kevin Brennan makes?
  - A. Children use too many electrical devices.
  - B. Children would learn by being outside more.
  - C. It's too risky for children to be outside on their own.
  - D. The most important thing is children's safety.

**READING PASSAGE 3**

**Three ways to Levitate a Magic Carpet**

It sounds like a science fiction joke, but it isn't. What do you get when you turn an invisibility cloak on its side? A mini flying carpet. So say physicists who believe the same exotic materials used to make cloaking devices could also be used to levitate tiny objects. In a further



breakthrough, two other research groups have come a step closer to cracking the mysteries of levitation.

Scientists have levitated objects before, most famously using powerful magnetic fields to levitate a frog. But that technique, using the repulsive force of a giant magnet, requires large amounts of energy. In contrast, the latest theories exploit the natural smaller amounts of energy produced by the quantum fluctuations of empty space.

In May 2006, two research teams led by Ulf Leonhardt at St Andrews University, UK, and John Pendry at Imperial College, London, independently proposed that an invisibility cloak could be created from exotic materials with abnormal optical properties. Such a cloaking device working in the microwave region - was manufactured later that year.

The device was formed from so-called 'metamaterials' exotic materials made from complex arrays of metal units and wires. The metal units are smaller than the wavelength of light and so the materials can be engineered to precisely control how electromagnetic light waves travel around them. They can transform space, tricking electromagnetic waves into moving along directions they otherwise wouldn't,' says Leonhardt.

Leonhardt and his colleague Thomas Philbin, also at St Andrews University, realised that this property could also be exploited to levitate extremely small objects. They propose inserting a metamaterial between two so-called Casimir plates. When two such plates are brought very close together, the vacuum between them becomes filled with quantum fluctuations of the electromagnetic field. As two plates are brought closer together fewer fluctuations can occur within the gap between them, but on the outer sides of the plates, the fluctuations are unconstrained. This causes a pressure difference on either side of the plates, forcing the plates to stick together, in a phenomenon called the Casimir effect.

Leonhardt and Philbin believe that inserting a section of metamaterial between the plates will disrupt the quantum fluctuations of the electromagnetic field. In particular, metamaterials have a negative refractive index, so that electromagnetic light waves entering a metamaterial bend in the opposite way than expected, says Leonhardt. That will cause the Casimir force to act in the opposite direction - forcing the upper plate to levitate. The work will appear in the *New Journal of Physics*.

Federico Capasso, an expert on the Casimir effect at Harvard University in Boston, is impressed. 'Using metamaterials to reverse the Casimir effect is a very clever idea,' he says. However he points out that because metamaterials are difficult to engineer, it's unlikely that they could be used to levitate objects in the near future.

But there are good signs that quantum levitation could be achieved much sooner, by other methods. Umar Mohideen at the University of California Riverside and his colleagues have successfully manipulated the strength of the Casimir force by increasing the reflectivity of one of the plates, so that it reflects virtual particles more efficiently. Modifying the strength of the Casimir force is the first step towards reversing it, says team member Galina Klimchitskaya at North-West Technical University in St Petersburg, Russia.

Capasso and his colleagues have also been working on an alternative scheme to harness a repulsive Casimir effect. Their calculations show that a repulsive Casimir force could be set up between a 423 micrometre-wide gold-coated polystyrene sphere and a silicon dioxide plate, if the two are immersed in ethanol. 'Although the Casimir force between any two substances — the ethanol and gold, the gold and the silicon dioxide, or the silicon dioxide and the ethanol - is positive, the relative strengths of attraction are different, and when you combine the materials, you should see the gold sphere levitate: he says.

Capasso's early experiments suggest that such repulsion could occur, and that in turn could be used to levitate one object above another. 'It's very early work, and we still need to make certain this is really happening, but we are slowly building up experimental evidence for quantum levitation,' says Capasso, who presented his results at a conference on Coherence and Quantum Optics in Rochester, New York, in June.

'This is a very exciting experimental result because it is the first demonstration that we can engineer a repulsive Casimir force,' says Leonhardt.

#### Questions 28-32

Do the following statements agree with the claims of the writer in Reading Passage 3? Write

- YES if the statement agrees with the writer's claims  
 NO if the statement contradicts the writer's claims  
 NOT GIVEN if it is impossible to say what the writer thinks about this

28. A mini flying carpet is a possibility according to some scientists.  
 29. Cloaking devices can be used for levitation.  
 30. Scientists now know all about levitation.  
 31. Things can be transported from place to place using empty space technology.  
 32. The most recent research into levitation has made use of large magnets.

#### Questions 33-37

Choose the correct letter, A, B, C or D.

33. Ulf Leonhardt and John Pendry

- A. worked together on a project in 2006.  
 B. both came up with the same idea.  
 C. invented the microwave oven.  
 D. used only basic objects in their research.

34. Metamaterials are

- A. similar to light, but with a smaller wavelength.  
 B. a combination of simple metals and wires.  
 C. able to change where electromagnetic waves go.  
 D. engineered when light waves travel around them.

35. The importance of the Casimir effect is that it

- A. doesn't require a vacuum in order to work.  
 B. increases the number of plates that can be used.  
 C. creates large and frequent fluctuations  
 D. creates pressure difference and stickiness.

36. Leonhardt and Philbin think that putting a metamaterial between two plates will

- A. cause the top plate to rise above the bottom plate.  
 B. stop electromagnetic light waves bending.  
 C. stop the Casimir force from working.  
 D. not affect electromagnetic fluctuations.

37. Why is it important to change the strength of the Casimir force?

- A. to reflect the plates  
 B. to help reverse the force  
 C. to see virtual particles better  
 D. to enable other scientists to progress

#### Questions 38-40

Complete each sentence with the correct ending A-F below.

38. Capasso is unconvinced that

39. Capasso has calculated that

40. Capasso has admitted that

- A. gold can be used to produce levitation.  
 B. a particular type of ethanol has to be used.  
 C. the levitation will last for only a few seconds.  
 D. using metamaterials will help lead to levitation in the short term.  
 E. his experiment will be extremely costly to perform.  
 F. his idea is still only a theory.

**IELTS INTENSIVE READING 5****READING PASSAGE 1****The Need to Belong**

No one likes to feel left out, ignored by colleagues at meetings or not be invited to the big party that everyone is talking about. Imagine not being part of a joke, or worse still, if the joke is on you. For most people, living the life of an outsider can have a negative effect on self-esteem and mood. It can even lead to negative behaviour. The pull to belong is extremely strong. Scientists believe that, in part, there is an evolutionary explanation for why we have this need to belong.

In the past, people hunted and cooked together in tribes and each member of the group would be assigned a role. As each member had a purpose, it meant that in the event of the loss of one person, the group as a whole would suffer. For this reason, they had a vested interest in protecting each other. To our prehistoric ancestors, membership of a group meant the difference between survival and death. Those who were rejected and excluded from joining a group had to fend for themselves and struggled to stay alive alone in the wild. Apart from protection, being part of a group also ensured that genes could be passed on to future generations. Although it is very different now from the way our primitive ancestors lived, our brains have not had time to evolve to fit today's lifestyles. In this day and age, it is no longer a matter of survival to be affiliated to a tribe or group, but the evolutionary instinct to find protection still lingers.

This inherent feeling of security that comes with being part of a group is powerful enough to make people employ both conscious and unconscious strategies to gain membership. One obvious way people try to be accepted into a group is self-presentation, which is the act of portraying yourself in the best possible light. An individual will attempt to outwardly display the characteristics which are important to the group's advancement. At the same time, they will conceal any parts of their personality that may be seen as undesirable or not useful to a group. An example of self presentation is the job application process. A candidate applying for a job will promote themselves as motivated, but is likely to hide the fact that they are disorganised. These conscious tactics that people use are not a surprise to anyone, but we also use other strategies unknowingly.

Psychologists Jessica Larkin, Tanya Chartrand and Robert Arkin suggested that people often resort to automatic mimicry to gain affiliation into groups, much like our primitive ancestors used to do. Before humans had the ability to speak, physical imitation was a method of begging for a place in the group. Most will be unaware they are doing it. Larkin and her co-workers decided to test this hypothesis. They took a group of student volunteers and had them play a game called Cyber ball a ball-tossing arcade game that resembled American football. The volunteers were led to believe they were all playing against each other, but in actual fact they were not. The computer was manipulating the game by passing the ball to some volunteers and excluding others.

The 'accepted' and 'rejected' students were then asked if they enjoyed the game and about their opinions of the other players. Participants were then put alone in a room and their natural foot movements were filmed. Then a female entered the room under the pretence of conducting a fake photo description task. The female deliberately moved her foot during the task, but not in a way that would be noticeable to the volunteer. It turned out that the rejected students mimicked the female's foot movements the most. This revealed that after exclusion, people will automatically mimic to affiliate with someone new.

However, Larkin and her colleagues wanted to go further. They believed that more often than not, in the real world, we actually know the people that reject us. How do we behave towards the group that we know has excluded us? The experiment was repeated with this question in mind. In the second experiment, only female volunteers played the Cyber ball game, during which they experienced rejection by either men or women. Then each volunteer did the fake photo task, but this time with a man and then a woman. The results clearly indicated that the female students that felt rejected would unconsciously make more of an effort to mimic members of their own in-group - that is, other women - rather than men. This deep-wired instinct to mimic was not only directed

towards random people, as initially thought, but targeted to specific groups, the particular group that did the rejecting in the first place.

To some, it is inconceivable why people will go to great lengths to be accepted into one of life's social groups or clubs, enduring rejection and sometimes humiliation in order to be accepted. You only have to look at college campuses, which are notorious for strict initiations inflicted on candidates desperately seeking membership. But it happens and will continue to happen, because the desire to belong is a very powerful force and a fundamental part of human nature.

#### Questions 1-5

Complete the summary. Choose **NO MORE THAN TWO WORDS** from the passage for each answer.

Modern man's basic need to belong to clubs and groups dates back to early history. Each person within the group had a 1.....to play and was considered integral to the entire groups dynamics and success. For an individual belonging to a group could affect their chances of 2..... In those times, few could avoid death living alone in 3..... Living with other humans offered is 4..... from danger. Staying in a group also meant that 5..... could be passed down no descendants.

#### Questions 6-10

Complete the flow chart below. Use **NO MORE THAN THREE WORDS** from the passage for each answer.

#### THE PROCEDURE FOR LARKIN'S EXPERIMENT

Volunteers believed they were playing a computer game similar to 6 .....

The computer was controlling the game play, 7..... to some and not others.

The volunteers gave their 8..... after the game.

Each volunteer first sat on their own in a room and had their foot movements 9.....

The volunteer took part in a task with a woman who 10..... on purpose.

#### Questions 11 -13

Choose the correct letter, A, B, C or D.

11. Which of the following is **NOT** mentioned in the first paragraph?

- A. one expert's view on evolution
- B. the consequences of being excluded
- C. being made fun of by the people around you
- D. a social event that people are eagerly awaiting

12. According to the article, which method do people consciously use to obtain membership into their chosen group?

- A. They tell the group they are strongly motivated.
- B. They convey the best parts of their personality to the group.
- C. They show how the group will be important to their lives.
- D. They alter aspects of their personality to suit others.

13. The writer's main purpose in writing this article is to

- A. explain how people feel when they face rejection.
- B. encourage people to go it alone and not be part of a group.
- C. show the unconscious drive behind the need to belong.
- D. compare how the modern lifestyle is different to the past.

## READING PASSAGE 2

**Is Technology Harming our Children's Health?**

Technology is moving at such a breakneck speed that it is enough to make your head spin. It can be difficult to keep up. However, with each new technological marvel come consequences. Much of the research conducted has shown the extent of the damage being done to our hearth by technology. It is a scary thought, and with teenagers and children being heavy consumers and users of these gadgets, they run the risk of being harmed the most.

The digital revolution in music has enabled people to download, store and listen to songs on a tiny portable device called an MP3 player. The process is quick and afterwards you can have access to a library of thousands of songs that can fit into your palm. But experts say that continuously listening to loud music on these small music players can permanently damage hair cells in the inner ear resulting in hearing loss. For instance, old-fashioned headphones have been replaced with smaller ones that fit neatly into the ear; instead of over them, which intensifies the sound. In addition to that, digital music does not distort and keeps its crystal clear sound even on loud settings which encourages children to crank up the volume. Combine that with the fact that many children will spend hours listening to their iPods and you have the recipe for hearing loss. Put into further perspective, most MP3 players can reach levels of 120 decibels, which is louder than a chainsaw or lawnmower. When you consider 85 decibels is the maximum safe decibel level set by treating experts over the course of a working day and that children will listen to music at higher decibel levels than that for long periods of time, hearing will invariably suffer.

Apart from hearing damage, there are other serious health risks. We are living in a wireless age. Calls can be made and received on mobiles from anywhere and the internet can be accessed without the need for cables. The advantages are enormous bringing ease and convenience to our lives. It is clear that mobiles and wireless technology are here to stay but are we paying the price for new technology? Studies have shown that the rapid expansion in the use of wireless technology has brought with it a new form of radiation called 'electro-pollution'.

Compared to two generations ago, we are exposed to 100 million times more radiation. The human body consists of trillions of cells which use faint electromagnetic signals to communicate with each other so that the necessary biological and physiological changes can happen. It is a delicate, natural balance. But this balance is being upset by the constant exposure to electromagnetic radiation (EMR) that we face in our daily lives and it is playing havoc with our bodies. EMR can disrupt and alter the way in which our cells communicate and this can result in abnormal cell behaviour. Some studies have shown that exposure to wireless technology can affect our enzyme production, immune systems, nervous system and even our moods and behaviour. The most dangerous part of the phone is around the antenna. This area emits extremely potent radiation which has been shown to cause genetic damage and an increase in the risk of cancer.

Research shows that teenagers and young adults are the largest group of mobile phone users. According to a recent *Eurobarometer* survey, 30 per cent of Europeans aged 12-13 own a mobile phone and the number of children five to nine years old owning mobiles has greatly increased over the years. Children are especially vulnerable because their brains and nervous systems are not as immune to attack as adults. Sir William Stewart, chairman of the National Radiological Protection Board, says there is mounting evidence to prove the harmful effects of wireless technologies and that families should monitor their children's use of them.

Besides the physical and biological damage, technology can also have serious mental implications for children. It can be the cause of severe addictive behaviour. In one case, two children had to be admitted into a mental health clinic in Northern Spain because of their addiction to mobile phones. An average of six hours a day would be spent talking, texting and playing games on their phones. The children could not be separated from their phones and showed disturbed behaviour that was making them fail at school. They regularly deceived family

members to obtain money to buy phone cards to fund their destructive habit. There have been other cases of phone addiction like this.

Technology may also be changing our brain patterns. Professor Greenfield, a top specialist in brain development, says that, thanks to technology, teenage minds are developing differently from those of previous generations. Her main concern is over computer games. She claims that living in a virtual world where actions are rewarded without needing to think about the moral implications makes young people lose awareness of who they are. She claims that technology brings a decline in linguistic creativity.

As technology keeps moving at a rapid pace and everyone clamours for the new must-have gadget of the moment, we cannot easily perceive the long-term effects on our health. Unfortunately, it is the most vulnerable members of our society that will be affected.

**Questions 14-18**

Complete the table below. Write NO MORE THAN TWO WORDS AND/OR A NUMBER from the passage for each answer.

**How MP3 players can threaten health**

MP3 player features		Harmful results	Effects
Problem A	new 14 ..... fit inside ears	creates intense sound	Damage to hear cells and loss of hearing
Problem B	15.....is distortion-free with clear quality sound	invites children to increase 16.....	
Problem C	capable of producing sound at 17.....	as loud as a lawnmower or chainsaw – over recommended safe 18.....	

**Questions 19-23**

Do the following statements agree with the claims of the writer in Reading Passage 2. Write

- Yes if the statement agrees with the writers views
- No if the statement contradicts the writer’s views
- NOT GIVEN if it is impossible to say what the writer thinks about this

- 19. There are considerable benefits to our wireless world.
- 20. Wireless technology is a permanent part of our lives.
- 21. Exposure to EMR can lead to criminal behaviour.
- 22. It is possible to become obsessed with technology.
- 23. Using technology always helps with academic success.

**Questions 24-26**

Answer the questions below using NO MORE THAN THREE WORDS for each answer.

- 24. According to Professor Greenfield, what kind of world do children occupy when playing computer games?
- 25. What does Professor Greenfield feel children don't pay attention to when playing computer games?
- 26. According to Professor Greenfield, what may be lower in teenagers who play a lot of computer games?

## READING PASSAGE 3

**A History of Finger printing**

A

To detectives, the answers lie at the end of our fingers. Fingerprinting offers an accurate and infallible means of personal identification. The ability to identify a person from a mere fingerprint is a powerful tool in the light against crime. It is the most commonly used forensic evidence, often outperforming other methods of identification. These days, older methods of ink fingerprinting, which could take weeks, have given way to newer, faster techniques like fingerprint laser scanning, but the principles stay the same. No matter which way you collect fingerprint evidence, every single person's print is unique. So, what makes our fingerprints different from our neighbours?

B

A good place to start is to understand what fingerprints are and how they are created. A fingerprint is the arrangement of skin ridges and furrows on the tips of the fingers. This ridged skin develops fully during foetal development as the skin cells grow in the mother's womb. These ridges are arranged into patterns and remain the same throughout the course of a person's life. Other visible human characteristics, like weight and height, change over time whereas fingerprints do not. The reason why every fingerprint is unique is that when a baby's genes combine with environmental influences such as temperature. It affects the way the ridges on the skin grow. It makes the ridges develop at different rates, buckling and bending into patterns. As a result, no two people end up having the same fingerprints. Even identical twins possess dissimilar fingerprints.

C

It is not easy to map the journey of how the unique quality of the fingerprint came to be discovered. The moment in history it happened is not entirely clear. However, the use of fingerprinting can be traced back to some ancient civilisations, such as Babylon and China, where thumbprints were pressed onto clay tablets to confirm business transactions. Whether people at this time actually realised the full extent of how fingerprints were important for identification purposes is another matter altogether. One cannot be sure if the act was seen as a means to confirm identity or a symbolic gesture to bind a contract, where giving your fingerprint was like giving your word.

D

Despite this uncertainty, there are those who made a significant contribution towards the analysis of fingerprinting. History tells us that a 14<sup>th</sup> century Persian doctor made an early statement that no two fingerprints are alike. Later in the 17<sup>th</sup> century, Italian physician Marcello Malpighi studied the distinguishing shapes of loops and spirals in fingerprints. In his honour, the medical world later named a layer of skin after him. It was, however, an employee for the East India Company, William Herschel who came to see the true potential of fingerprinting. He took fingerprints from the local people as a form of signature for contracts, in order to avoid fraud. His fascination with fingerprints propelled him to study them for the next twenty years. He developed the theory that fingerprints were unique to an individual and did not change at all over a lifetime. In 1880 Henry Faulds suggested that fingerprints could be used to identify convicted criminals. He wrote to Charles Darwin for advice, and the idea was referred on to Darwin's cousin Sir Francis Galton. Galton eventually published an in-depth study of fingerprint science in 1892.

E

Although the fact that each person has a totally unique fingerprint pattern had been well documented and accepted for a long time, this knowledge was not exploited for criminal identification until the early 21<sup>st</sup> century. In the past, branding, tattooing and maiming had been used to mark the criminal for what he was. In some countries, thieves would have their hands cut off. France branded criminals with the fleur-de-lis symbol. The Romans tattooed mercenary soldiers to stop them from becoming deserters.

F

For many years police agencies in the Western world were reluctant to use fingerprinting, much preferring the popular method of the time, the Bertillon System, where dimensions of certain body parts were recorded to identify a criminal. The turning point was in 1903 when a prisoner by the

name of Will West was admitted into Leavenworth Federal Penitentiary. Amazingly, Will had almost the same Bertillon measurements as another prisoner residing at the very same prison, whose name happened to be William West. It was only their fingerprints that could tell them apart. From that point on fingerprinting became the standard for criminal identification.

G

Fingerprinting was useful in identifying people with a history of crime and who were listed on a database. However, in situations where the perpetrator was not on the database and a crime had no witnesses, the system felt short. Fingerprint chemistry is a new technology that can work alongside traditional fingerprinting to find more clues than ever before. From organic compounds left behind on a print, a scientist can tell if the person is a child, an adult, a mature person or a smoker, and much more. It seems, after all these years, fingers continue to point the way.

**Questions 27-32**

Reading Passage 3 has seven paragraphs, A-G. Choose the correct heading for paragraphs B-G from the list of headings below.

List of Headings

- i. Key people that made a difference
- ii. An alternative to fingerprinting
- iii. The significance of prints
- iv. How to identify a criminal
- v. Patterns in the making
- vi. Family connections
- vii. Exciting new developments
- viii. A strange coincidence
- ix. Punishing a criminal
- x. An uncertain past

- |   |
|---|
| <p>Example: paragraph A – iii</p> <p>27. Paragraph B</p> <p>28. Paragraph C</p> <p>29. Paragraph D</p> <p>30. Paragraph E</p> <p>31. Paragraph F</p> <p>32. Paragraph G</p> |
|---|

**Questions 33-35**

Complete the sentences. Choose NO MORE THAN TWO WORDS from the passage for each answer.

- 33. Unlike other ..... that you can see, fingerprints never change.
- 34. Although genetically the same, .....do not share the same fingerprints.
- 35. A fingerprint was a substitute for a ..... in Indian contracts.

**Questions 36-40**

Do the following statements agree with the information given in Reading Passage 3?

Write

- True if the statement agrees with the information
- False if the statement contradicts the information
- Not given if there is no information on this

- 36. Fingerprinting is the only effective method for identifying criminals.
- 37. The ridges and patterns that make up fingerprints develop before birth.
- 38. Malpighi conducted his studies in Italy.
- 39. Roman soldiers were tattooed to prevent them from committing violent crimes.
- 40. Fingerprint chemistry can identify if a fingerprint belongs to an elderly person.



## IELTS INTENSIVE READING 6

## READING PASSAGE 1

**Australia's Convict Colonies**

A

The 1700s in Britain saw widespread poverty and rising crime, and those convicted of crimes faced harsh penalties, including transportation to one of Britain's overseas colonies. Since 1615, convicts had been transported to Britain's American colonies, both as punishment and a source of labour, but this practice was halted by the Revolutionary War in America (1775-1783). The British government decided to establish a new prison colony, and Botany Bay in New South Wales was chosen as the site. (Captain Cook, exploring the southeast coast of Australia in 1770, had named the land New South Wales and claimed it for Britain.) Between 1787 and 1868, almost 160,000 convicts, of whom about 25,000 were women, were sent to Australia to serve sentences ranging from 7 years to life.

B

Eleven ships set sail from England in 1787 to take the first group of about 750 British convicts to Australia. The fleet reached Botany Bay in January 1788, but nearby Sydney Cove was selected as a more suitable site for the new settlement, which later became the city of Sydney. The first few years were difficult, with severe food shortages; by 1792, however, there were government farms and private gardens. Convicts worked on these farms, or on construction projects such as building roads and bridges. Although the settlement was a prison colony, few convicts served their sentences in jail. They lived in houses they had built themselves, and established families, businesses and farms. A settlement was also established on Norfolk Island, where some convicts were sent for crimes committed after arrival in the colony. Two more settlements were established on Van Diemen's Land (now Tasmania), in 1803 and 1804.

C

Convicts not involved in public work were assigned to free settlers, providing labour in exchange for food, clothing and shelter. Some masters treated the convicts cruelly, and the punishment of convicts, particularly in the early days, could be arbitrary and savage. Lachlan Macquarie, governor of New South Wales from 1809 to 1819, adopted a more humane approach. He encouraged convicts to reform by rewarding good behaviour, even granting pardons to convicts before their sentence was completed. These emancipists, as they were called, were given land and government assistance to help them start farming. His policies were unpopular both with British authorities and wealthy free settlers, however, and the next governors were under orders to ensure that life for convicts became much stricter and more controlled. There were harsher punishments for second offenders, such as working in the 'iron gangs' where men were chained together to carry out exhausting work on the roads, or being sent to penal settlements where punishment was deliberately brutal so that it would act as a deterrent.

D

In the early years of settlement, the convicts greatly outnumbered free immigrants and settlers. In 1810, convicts made up almost 60 percent of the population, and over 20,000 new convicts arrived between 1821 and 1830. Even in 1831, convicts still comprised 45 percent of the population, with ex-convicts and emancipists making up another 30 percent. 25 percent of the population now consisted of people born in the colonies, and free people outnumbered convicts

E

The first group of free settlers had arrived in Australia in 1793 to seek their fortune in the new land. Their numbers grew, with about 8,000 free settlers arriving in the 1820s to take advantage of free land grants and cheap convict labour. In 1831, the British government offered money to support new settlers, hoping to attract skilled workers and single women as immigrants. Between 1831 and 1840, more than 40,000 immigrants arrived in Australia.

F

During the 1820s there was a lengthy campaign to win certain rights for emancipists, which was opposed by wealthy free settlers. In the 1830s, free immigrants to New South Wales and Van Diemen's Land, unhappy about living in a prison colony where civil liberties were restricted and convict labour resulted in low wages, increasingly voiced their opposition to transportation. Again, wealthy landowners disagreed, but a growing number of reformers in England were also

opposed to convict transportation. In 1838, a committee set up by the British Parliament recommended that the government end transportation to New South Wales and Van Diemen's Land, and abolish assignment. The British duly abolished assignment, and transportation - at least to New South Wales - was halted in 1840.

**G**

Transportation continued, however, to other colonies and settlements, in the 1840S, most British convicts were sent to Van Diemen's Land, where the British government introduced a convict system based on stages of reform, with the convicts gaining increasing levels of freedom for continued good behaviour. Transportation to the eastern colonies was abolished in 1852. In contrast, the convict system in Western Australia began in 1850, at the request of the Western Australian government, and continued until 1868. Convicts served part of their sentences in Britain before being transported to the colony, where they worked on badly-needed public construction projects under a system similar to that tried in Van Diemen's Land.

### Questions 1-3

Which THREE of the following statements are true of free settlers in the Australian prison colonies, according to the text? Choose THREE letters A-H. NB Your answers may be given in any order.

- A. They were mainly skilled Workers and single women.
- B. They all welcomed Governor Macquarie's policies.
- C. 25 percent of them were born in the Colonies.
- D. 160,000 of them went to Australia between 1787 and 1868.
- E. 8,000 of them arrived in Australia in the 1820s.
- F. They established families, businesses and farms.
- G. Convicts who were assigned to them provided them with labour.
- H. They campaigned in favour of emancipist rights.

### Questions 4-9

Reading Passage 1 has seven paragraphs, A—G. Choose the correct heading for paragraphs B—G from the list of headings below.

#### List of Headings

- i. Free settlers
- ii. Transportation of convicts
- iii. The end of transportation
- iv. Convict life
- v. The colonial population
- vi. The treatment of convicts
- vii. Opponents of transportation
- viii. The first settlements

Example Paragraph A - ii (answer)

4. Paragraph B
5. Paragraph C
6. Paragraph D
7. Paragraph E
8. Paragraph F
9. Paragraph G

### Questions 10- 13

Complete the notes below. Write NO MORE THAN THREE WORDS for each answer.

#### Australia's Convict Colonies Events preceding first settlement

- 1615 - convicts first transported to 10..... Controlled by Britain
- 1770 - Cook claims SE Australian coast for Britain, calling it 11.....
- 1775 - 1783 - Revolutionary War in America halts transportation there
- 1787 - Botany Bay chosen as site for new 12..... ; first convict fleet sets sail
- 1788 - fleet reaches Botany Bay but 13..... chosen instead

## READING PASSAGE 2

**Crows Can be Craftsmen too**

A remarkable colony of inventors has emerged on an isolated Pacific island. They can fashion tools out of materials scavenged from the rainforest. They can even customise a tool for a given job, Meet the crows of New Caledonia.

Thinkers as diverse as Freud, Engels and Thomas Carlyle once pointed to the use of tools as being a defining behaviour of human beings. Then it was found that many animals also used them, from the 'fishing sticks' of apes to the rocks dropped on ostrich eggs by Egyptian vultures. Crows are particularly crafty. Earlier studies showed that they are almost human-like in their use of tools, with technological features that match the stone and bone tool cultures that emerged among primitive humans between 2.5 million and 70,000 BC.

But only humans were thought to have the brain power required for cumulative technological evolution. This is the skill for innovation that took our ancestors two million years ago from creating flakes of flint, for use in cutting, to honing knives, blades, arrowheads and axe-heads. Now this unique attribute of humans has also turned out to be a flattering delusion. A new study shows that the crows of New Caledonia are inventive. 'With their evolving leaf tools, the birds have levered man off his pedestal.

Dr Gavin Hunt and Dr Russell Gray of the University of Auckland have spent the past decade studying feathered technology in New Caledonia, 900 miles north-east of Australia. After an intensive field survey of local crow industry, the scientists found that the birds rip the leaves of the pandanus tree to fashion three distinct types of tool for grub and insect extraction: wide, narrow and tapered.

Long ago, the birds discovered that they could rip the serrated edge off the leaves to make a wide tool. The skill spread and the crows honed tools with finer working tips, by either narrowing tools or tapering them. (Because the leaves are reinforced by tough parallel fibres, the tapered design is made in steps. The crow nips the leaf ribs along the fibres, makes another cut and tears again, repeating until it has a tool with usually two, three or four steps.)

Leaf tool manufacture is an example of culture: the birds learn through example and their tool-making wisdom grows in sophistication down the generations. The crows appear to have the cognitive requirements for cumulative, though rudimentary, technological evolution, said Dr Gray. 'Tool manufacture in New Caledonian crows shows striking flexibility and innovation. The ability of the birds to innovate is further shown by their making of other tools. They often strip a twig of leaves and cut it off just below a shortened offshoot to create a hook to get bugs out. They also use simpler tools to extract grubs from the dead wood of trees.

Prof Alex Kacelnik, fellow of Pembroke College, Oxford, praised the study as 'extremely important'. It complements his own research, with Dr Jackie Chappell and Alex Weir which has turned Betty the New Caledonian crow into a star by revealing her to be the first animal, other than man, to show a basic understanding of cause and effect.

Betty began making tools after her partner snatched away a hook made for her by the researchers, forcing her to make her own from garden wire to fish out morsels from a tube. She wedged the end of the wire into the base of the food tube and turned her head to form the hook. What amazed the researchers is that she can even adapt her hooks if they are not up to the job. Something that even chimpanzees are unable to do. Although chimps use sticks in experiments, they have not shown any human-like understanding of basic physical laws. 'When she starts bending the wire it is as if she has a clear objective, even correcting the angle of the hook if it is not right', Said Prof Kacelnik. Although many animals use tools, purposeful modification of objects to solve new problems, without training or prior Experience, is virtually unknown.

While we have been emphasising the Individual ability of animals like Betty to solve problems, the New Zealand team has been emphasising tool manufacture, the cultural traditions and transmission of information in the wild,' said Prof Kacelnik. Both strands of research are related by how the crows are not genetically programmed to use a tool, like a spider and his web. Instead, the birds creatively invent new kinds of tools to solve problems and can share skills with others.

The crow family are the Einsteins of the avian world, though Prof Kacelnik added that, at least in terms of tool making, the Pacific crows are smarter than their British cousins. 'We have not yet identified what it is that makes these crows so special, though it is something to do with ecological circumstances', said Prof Kacelnik.

Once scientists have got to the bottom of what makes Pacific crows master toolmakers, they may have to think again about how this skill evolved in humans

**Questions 14-17**

Complete the diagrams. Choose **NO MORE THAN TWO WORDS** from the passage for each answer.

14. The crow makes a cut in the leaf then .....away a section



15. ....leaf  
Evolution of the crows leaf tool

16. ....tool   
narrow tool 

17.....tool with 2, 3 or 4 steps 

**Questions 18—22**

Classify the following statements as referring to the crow(s) in

- A. the study by Hunt and Gray
- B. the study by Kacelnik, Chappell and Weir
- C. both studies

Write the correct letter, A, B or C.

- 18. can share tool-making skills with other crows
- 19. can make special tools for at particular purpose
- 20. can solve problems by understanding rather than learning
- 21. can make tools better than British crows can
- 22. can manufacture hooks to extract food

**Questions 23-26**

Complete the summary, Choose **NO MORE THAN TWO WORDS** from the passage for each answer.

It used to be thought that only human beings used tools. Even after we learned that many other 23. .... also do so, it was still believed that only humans were intelligent enough to gradually evolve better tools. A study of crows in 24 ..... however, shows that these birds use a leaf tool which has been evolved over Several generations. A crow in another study has shown the human-like ability to understand 25..... in order to manufacture tools, which not even 26..... can do.

## READING PASSAGE 3

**Coming into the World** - *A little-known Island community comes in from the cold.*

Back in early 1961, few outside the corridors of dwindling British power had heard of the archipelago centred on the main island of Tristan da Cunha, from which the scattered islands that make up the group took their name.

It would take a dramatic volcanic eruption, and an emergency evacuation that would grab the attention of the media, to bring attention to this mysterious outpost of the British Empire. It seemed that the islands, no more than pin-pricks in the Southern Atlantic Ocean, almost equidistant between Buenos Aires in South America and Cape Town in South Africa, preferred not to be found.

The same can be said of the 290 or so residents of Tristan da Cunha at that time. They lived on the remotest island on the entire planet. There was no airport, nor was there space to build one on this mountainous carbuncle projecting from the ocean. The only harbour, impenetrable during rough weather, was 1,500 miles distant from the nearest mainland port, Cape Town. Communications with the outside world relied predominantly on signals to passing fishing boats and the annual visit of the vessel that supplied the islanders with the goods they could not produce themselves.

For this was a self-reliant community, proud of their ability to survive and help each other in times of adversity. Colonised early in the 19<sup>th</sup> century, until December 1942, money had not been exchanged on the Island. However, war-time conditions and new development, in particular a new fishing industry, saw the beginnings of links which meant that the Islanders had to accept they were now part of the modern world, however much the older members of the community might resist such change.

The lives of the islanders ticked quietly along, largely ignored as the government of Britain struggled with larger events on the world stage, until the beginning of August 1961. Earth tremors and rock falls began on the 6<sup>th</sup>, but by October the situation had got so bad that the island had to be evacuated. The entire population eventually found themselves in England, where they were met with unwanted and unexpected attention from the media. They were housed at a military camp just outside the port of Southampton.

Coming from a sub-tropical Island and having had little exposure to the illnesses and chill endured by the natives of the British Isles during winter, several of the elder islanders succumbed. The government did not seem to know what to offer the islanders. There was no news about what was happening to their homeland, and the future looked very bleak. These were people who had built up their own way of life for over one hundred and fifty years. They were a compact community who shared only seven family names between them, and now it seemed that their way of life was to be destroyed.

Fortunately, and despite the islanders reluctance to have any dealings with the media, who they suspected looked on them as historical curiosities, the attention helped keep their plight in the public eye. Eventually, word came through that the island was again habitable and, despite strong resistance from the British Government, the vast majority of the Islanders voted to return, turning their backs on the temptations of the brighter lights of their temporary home in favour of their own.

The last of the returning islanders arrived on November 1963 and, with the rebuilding of the crawfish canning industry and a growing demand for the island's stamps amongst dedicated collectors following the publicity caused by the volcanic eruption, the local economy soon recovered, although communications remained as difficult as they had ever been. Michael Parsons, a young British teacher who was employed on the island, recalls that there was no

television and mail from the outside world arrived just eight times a year. 'I was allowed to send a 100-word telegram home once a month' he recalls, 'and getting news from home brought a lump to my throat.'

Things have changed with developments in technology, but at the beginning of the present century the island was again cut off from the rest of the world when, on May 23<sup>rd</sup> 2001, a hurricane tore through the area. It caused extensive damage, knocking out the radio station and satellite telephone link as well as leaving the islanders without electricity. It would be a week before news of the disaster reached London and several more weeks before a rescue package could be agreed to help the islanders rebuild.

Today the island boasts its own Internet cafe. For the first time people can see what the items they wish to obtain from abroad actually look like before they purchase them — a big bonus in a place where you have to wait many months to receive an order which might prove to be unsuitable for the purpose you had in mind. At last, it seems, Tristan da Cunha has joined the world.

**Questions 27 and 28** Choose the correct letter, A, B, C or D.

27. The writer describes the islands of Tristan da Cunha as
- difficult to find in an emergency.
  - a place the media didn't understand.
  - somewhere different countries claimed to own.
  - unknown to most members of the public.
28. What does the writer say about the islanders?
- They could go for years with no contact with outsiders.
  - They had no means of leaving the island to speak to others.
  - They exchanged messages with boats that went past them.
  - They travelled to the mainland on the supply ship.

**Questions 29-34**

- YES if the statement agrees with the Writer's views  
 NO if the statement contradicts the writer's views  
 NOT GIVEN if it is impossible to say what the writer thinks about this

- People living on Tristan da Cunha are totally self-sufficient.
- The islanders often get ill.
- Some islanders were reluctant to return after the volcanic eruption.
- The selling of postage stamps has generated revenue for the islanders.
- There is no television service on Tristan da Cunha.
- Communications with the island are often interrupted.

**Questions 35-40**

Complete the summary. Choose NO MORE THAN TWO WORDS from the passage for each answer.

First colonized in the early part of the 19th century; Tristan da Cunha remained unknown to many people in the rest of the world until a 35..... forced the small population of this remote island to evacuate their homes and brought their existence to the attention of 36..... After spending two years as refugees in 37....., the British Government reluctantly allowed them to return to the island once it had been established that the danger had passed. The 38..... of the island improved when rebuilding work had been completed, partly because of a new interest in the 39..... Disaster was to strike the island again nearly forty years later when a 40..... destroyed many buildings on the island.



Recent years have seen more novel construction developments around the world. In the past, in many countries, Holland and the UK included, marshes and flood plains have been reclaimed from the sea. Like the city of Venice in Italy, housing complexes and even airports have now been constructed off-shore to amazing effect. In Japan, Kansai International Airport has been built off-shore on a man-made island at vast expense and in Dubai a very imaginative and expensive housing complex in the shape of a palm tree is being built just off the coast on land created by a construction company. However, these and other developments are at risk from rising sea levels as a consequence of global warming.

#### Section D

But where will the human race go when planet earth is full? There have been many theories put forward about the human population moving to outer space. Marshall Savage (1992, 1994), for example, has projected that the human population will reach five quintillion throughout the solar system by the year 3000, with the majority living in the asteroid belt. Arthur C Clarke, a fervent supporter of Savage, now argues that by the year 2057 there will be humans on the Moon, Mars, Europa, Ganymede, Titan and in orbit around Venus, Neptune and Pluto. Feeman Dyson (1999) favours the Kuiper belt as the future home of humanity, suggesting this could happen within a few centuries.

#### Section E

Habitation in outer space in huge stations is no longer just a dream, but a reality. A permanent international space station now orbits the earth. The first commercial tourist recently went into outer space with more trips planned for the near future. This is only a beginning, but the development of space hotels is not far-off. There is no knowing where mankind may end up. But the ideas about off-world habitation are not fanciful and I am sure I am not alone in fantasizing about summer holidays spent watching the moons rising in some far-flung planet or on a floating hotel somewhere on the Andromeda nebula.

#### Questions 5-8

Complete the sentences below. Choose NO MORE THAN TWO WORDS from the passage for each answer.

5. The movement of rural people to cities is a.....
6. Land is now a very....., as a result of the growing demand for space.
7. The feeding of the human race will perhaps be guaranteed by changes in.....
8. Besides the demands of accommodation, land is needed for various.....

#### Questions 9-13

Do the following statements agree with the claims of the writer in Reading Passage ? In boxes 9-13 on your answer sheet write

- |           |  |
|-----------|--|
| YES       | if the statement reflects the claims of the writer           |
| NO        | if the statement contradicts the claims of the writer        |
| NOT GIVEN | if it is impossible to say what the writer thinks about this |

9. The destruction of land for food and firewood is linked to desertification.
10. Shortage of space has also led to underground building construction.
11. The building of the airport in Japan cost much more than that of the housing complex in Dubai.
12. Arthur C Clarke was the only person to predict that mankind will inhabit other parts of the solar system.
13. The concept of the habitation of outer space by mankind is unimaginable.

### Reading Passage 2

## THE HISTORY OF SALT

1. Salt is so simple and plentiful that we almost take it for granted. In chemical terms, salt is the combination of a sodium ion with a chloride ion, making it one of the most basic molecules on earth. It is also one of the most plentiful: it has been estimated that salt deposits under the state of Kansas alone could supply the entire world's needs for the next 250,000 years.
2. But salt is also an essential element. Without it, life itself would be impossible since the human body requires the mineral in order to function properly. The concentration



of sodium ions in the blood is directly related to the regulation of safe body fluid levels. And while we are all familiar with its many uses in cooking, we may not be aware that this element is used in some 14,000 commercial applications. From manufacturing pulp and paper to setting dyes in textiles and fabric, from producing soaps and detergents to making our roads safe in winter, salt plays an essential part in our daily lives.

3. Salt has a long and influential role in world history. From the dawn of civilization, it has been a key factor in economic, religious, social and political development. In every corner of the world, it has been the subject of superstition, folklore, and warfare, and has even been used as currency.
4. As a precious and portable commodity, salt has long been a cornerstone of economies throughout history. In fact, researcher M.R. Bloch conjectured that civilization began along the edges of the desert because of the natural surface deposits of salt found there. Bloch also believed that the first war - likely fought near the ancient city of Essalt on the Jordan River - could have been fought over the city's precious supplies of the mineral.
5. In 2200 BC, the Chinese emperor Hsia Yu levied one of the first known taxes. He taxed salt. In Tibet, Marco Polo noted that tiny cakes of salt were pressed with images of the Grand Khan to be used as coins and to this day among the nomads of Ethiopia's Danakil Plains it is still used as money. Greek slave traders often bartered it for slaves, giving rise to the expression that someone was "not worth his salt." Roman legionnaires were paid in salt - a *salarium*, the Latin origin of the word "salary."
6. Merchants in 12th-century Timbuktu - the gateway to the Sahara Desert and the seat of scholars - valued this mineral as highly as books and gold. In France, Charles of Anjou levied the "gabelle," a salt tax, in 1259 to finance his conquest of the Kingdom of Naples. Outrage over the gabelle fueled the French Revolution. Though the revolutionaries eliminated the tax shortly after Louis XVI, the Republic of France re-established the gabelle in the early 19th Century; only in 1946 was it removed from the books.
7. The Erie Canal, an engineering marvel that connected the Great Lakes to New York's Hudson River in 1825, was called "the ditch that salt built." Salt tax revenues paid for half the cost of construction of the canal. The British monarchy supported itself with high salt taxes, leading to a bustling black market for the white crystal. In 1785, the earl of Dundonald wrote that every year in England, 10,000 people were arrested for salt smuggling. And protesting against British rule in 1930, Mahatma Gandhi led a 200-mile march to the Arabian Ocean to collect untaxed salt for India's poor.
8. In religion and culture, salt long held an important place with Greek worshippers consecrating it in their rituals. Further, in Buddhist tradition, salt repels evil spirits, which is why it is customary to throw it over your- shoulder before entering your house after a funeral: it scares off any evil spirits that may be clinging to your back. Shinto religion also uses it to purify an area. Before sumo wrestlers enter the ring for a match - which is in reality an elaborate Shinto rite - a handful is thrown into the center to drive off malevolent spirits.
9. In the Southwest of the United States, the Pueblo worship the Salt Mother. Other native tribes had significant restrictions on who was permitted to eat salt. Hopi legend holds that the angry Warrior Twins punished mankind by placing valuable salt deposits far from civilization, requiring hard work and bravery to harvest the precious mineral. In 1933, the Dalai Lama was buried sitting up in a bed of salt. Today, a gift of salt endures in India as a potent symbol of good luck and a reference to Mahatma Gandhi's liberation of India.

10. The effects of salt deficiency are highlighted in times of war, when human bodies and national economies are strained to their limits. Thousands of Napoleon's troops died during the French retreat from Moscow due to inadequate wound healing and lowered resistance to disease - the results of salt deficiency.

**Questions 14-16** Choose THREE letters A-H.

Which THREE statements are true of salt?

- A. A number of cities take their name from the word salt.
- B. Salt contributed to the French Revolution.
- C. The uses of salt are countless.
- D. Salt has been produced in China for less than 2000 years.
- E. There are many commercial applications for salt.
- F. Salt deposits in the state of Kansas are vast.
- G. Salt has few industrial uses nowadays.
- H. Slaves used salt as a currency.

**Questions 17-21** Complete the summary.

Choose NO MORE THAN TWO WORDS from the passage for each answer. Write your answers in boxes 17-21 on your answer sheet.

Salt is such an 17.....that people would not be able to live without it. As well as its uses in cooking, this basic mineral has thousands of business 18.....ranging from making paper to the manufacture of soap. Being a prized and 19....., it has played a major part in the economies of many countries. As such, salt has not only led to war, but has also been used to raise 20.....by governments in many parts of the world. There are also many instances of its place in religion and culture, being used as a means to get rid of evil 21.....

**Questions 22-27**

Do the following statements agree with the information in Reading Passage 2?

TRUE if the statement agrees with the information  
 FALSE if the statement contradicts the information  
 NOT GIVEN if there is no information about the statement

- 22. It has been suggested that salt was responsible for the first war.
- 23. The first tax on salt was imposed by a Chinese emperor.
- 24. Salt is no longer used as a form of currency.
- 25. Most of the money for the construction of the Erie Canal came from salt taxes.
- 26. Hopi legend believes that salt deposits were placed far away from civilization to penalize mankind
- 27. A lack of salt is connected with the deaths of many of Napoleon's soldiers during the French retreat from Moscow.

Reading Passage 3

## Volunteering:

*enriching others and helping oneself*

- A. Volunteering, some might mistakenly think, embraces a plethora of people from all walks of life as well as activities, but data from the other side of the world suggest otherwise. A 2001 survey on who participated in volunteering by the Office for National Statistics (ONS) in the United Kingdom (UK) revealed that people in higher income households are more likely than others to volunteer. In England and Wales, 57 per cent of adults with gross annual household incomes of £75,000 or more, have volunteered formally (such as raising or handling money for a charity or being a member of a committee) in the 12 months prior to the survey date. They were almost twice as likely to have done so than those living in households with an annual income under £10,000.

- B. As well as having high household incomes, volunteers also tend to have higher academic qualifications, be in higher socio-economic groups and be in employment. Among people with a degree or postgraduate qualification, 79 per cent had volunteered informally and 57 per cent had volunteered formally in the previous 12 months. For people with no qualifications the corresponding proportions were 52 per cent and 23 per cent. But voluntary work is certainly not the exclusive preserve of the rich, nor should it be. Does the answer not lie perhaps in the fact that the rich tend to have money to allow them the time to become involved in voluntary work compared to less well-off people?
- C. A breakdown in the year 2000 of the range of volunteering activities taken from The Australian Bureau of Statistics gives an idea of the scale of activities in which people are typically involved. Eleven sectors are given ranging from Community and Welfare, which accounted for just over a quarter of the total hours volunteered in Australia, to Law/justice/politics with 1.2 percent at the other end of the scale. Other fields included sport/recreation, religious activities and education, following at 21.2 per cent, 16.9 and 14.3 per cent respectively. Foreign/international volunteer work accounted for 2.4 per cent of the total hours. The data here also seem to point to a cohort of volunteers with expertise and experience.
- D. The knock-on effect of volunteering on the lives of individuals can be profound. Voluntary work helps foster independence and imparts the ability to deal with different situations, often simultaneously, thus teaching people how to work their way through different systems. It therefore brings people into touch with the real world; and, hence, equips them for the future.
- E. Initially, young adults in their late teens might not seem to have the expertise or knowledge to impart to others that say a teacher or agriculturalist or nurse would have, but they do have many skills that can help others. And in the absence of any particular talent, their energy and enthusiasm can be harnessed for the benefit of their fellow human beings, and ultimately themselves. From all this, the gain to any community no matter how many volunteers are involved is immeasurable.
- F. Employers will generally look favourably on people who have shown an ability to work as part of a team. It demonstrates a willingness to learn and an independent spirit, which would be desirable qualities in any employee. So to satisfy employers' demands for experience when applying for work, volunteering can act as a means of gaining experience that might otherwise elude would-be workers and can ultimately lead to paid employment in the desired field.
- G. But what are the prerequisites for becoming a volunteer? One might immediately think of attributes like kindness, selflessness, strength of character, ability to deal with others, determination, adaptability and flexibility and a capacity to comprehend the ways of other people. While offering oneself selflessly, working as a volunteer makes further demands on the individual. It requires a strength of will, a sense of moral responsibility for one's fellow human beings, and an ability to fit into the ethos of an organization or community. But it also requires something which in no way detracts from the valuable work done by volunteers and which may seem at first glance both contradictory and surprising: self-interest.
- H. Organizations involved in any voluntary work have to be realistic about this. If someone, whatever the age, is going to volunteer and devote their time without money, they do need to receive something from it for themselves. People who are unemployed can use volunteer work as a stepping-stone to employment or as a means of finding out whether they really like the field they plan to enter or as a way to help them find themselves.
- I. It is tempting to use some form of community work as an alternative to national service or as punishment for petty criminals by making the latter for example clean up parks, wash away graffiti, work with victims of their own or of other people. This may be

acceptable, but it does not constitute volunteer work, two cardinal rules of which are the willingness to volunteer without coercion and working unpaid.

**Questions 28-33**

Reading Passage 3 has nine paragraphs A-I. Which paragraph contains the following information? Write the correct letter, A-I, in boxes 28-33 on your answer sheet.

- 28. a description of what does not satisfy the criteria for volunteer work
- 29. the impact of voluntary work on the development of individuals
- 30. the requirement for both selflessness and self-interest in volunteers
- 31. various areas in which people volunteer
- 32. the benefit of voluntary work for the young
- 33. a mistaken view of volunteering

**Questions 34-37**

Choose the correct letters A, B, C or D.

Write the correct letter in boxes 34-37 on your answer sheet.

- 34. The ONS survey was done to find out
  - A. why people undertook volunteering.
  - B. how many people participated in volunteering.
  - C. how many rich people did volunteer work.
  - D. which people were involved in volunteering.
- 35 The ONS survey found that people with university qualifications were
  - A. as likely to volunteer as those with no qualifications.
  - B. more likely to volunteer than those with no qualifications.
  - C. less likely to volunteer than those with no qualifications.
  - D. the only group likely to do formal volunteer work.
- 36 It is suggested that rich people volunteer as a result of having
  - A. clearer goals.
  - B. fewer children.
  - C. more spare time.
  - D. greater guilt.
- 37 Volunteer work benefits people by teaching them how to
  - A. function in systems.
  - B. communicate clearly.
  - C. deal with failure.
  - D. overcome shyness.

**Questions 38-40**

Complete each sentence with the correct ending, A-F below.

Write the correct letter, A-F, in boxes 38-40 on your answer sheet.

- 38 One of the requirements of being a volunteer is being able to .....
- 39 Volunteering can be used as a way for the unemployed to .....
- 40 Employers in general tend to .....

- A. consider workers with volunteer work experience an asset.
- B. gain a very well paid job.
- C. gain access to a job in a field of interest.
- D. benefit most from volunteer work.
- E. understand how people behave.
- F. want much younger workers.

## **Seaweed for human consumption**

Seaweeds are algae that live in the sea or in brackish water. Scientists often call them 'benthic marine algae', which just means 'attached algae that live in the sea'. Seaweeds come in three basic colours: red, green, and brown: dulse is the red seaweed; sea lettuce is amongst the green algae; and the brown is a wrack. Red and brown algae are almost exclusively marine, whilst green algae are also common in freshwater and in terrestrial situations. Many of these algae are very ancient organisms, and although lumped together as 'algae' are not actually closely related, having representatives in four of the five kingdoms of organisms. There are about 10,500 species of seaweeds, of which 6,500 are red algae (Rhodophyta).

The trend today is to refer to marine algae used as food as 'sea-vegetables'. The main species used in Ireland at present are dulse, carrageen moss, and various kelps and wracks. Dulse - also known as dillisk in a number of areas - is a red alga that is eaten on both sides of the North Atlantic. Generally only eaten in Ireland after it has been dried, it is frequently sold in small packets, most commonly in the west and north. About 16 tonnes are used in Ireland at present; the species is also eaten in Canada, Iceland, Norway, France and Scotland. About 53 tonnes of carrageen moss were gathered in Ireland in 1994.

Whilst dulse and carrageen moss are worthy sea-vegetables with a history of utilisation and a small but proven market, other species also show considerable promise. Our kelp resources are considerably under-utilised. All of the kelp species are edible but *Laminaria saccharina* is probably the most palatable as it has a somewhat sweet taste, probably due to its high levels of mannitol, and it also cooks better.

Two other brown algae with potential as food are currently under investigation by us: *Himanthalia elongata*, known in some places as thongweed, and *Alaria esculenta*, also known as dabberlocks or murlins. *Himanthalia* is eaten in France after drying or pickling ('Spaghettis demer'), and plants are sold in Ireland dried. After soaking in water it makes a surprisingly fine accompaniment to a mixed salad; it does not have the strong seaweedy taste that some dislike. With the aid of a basic research grant from Forbairt, the Irish research and development body, we are examining the growth and life cycle of populations of this species on the west coast. Plants are easy to collect but must be dried quickly and packaged well to preserve their excellent taste and mouth feel.

*Alaria* is a large, kelp-like brown alga that grows on exposed shores; In Ireland, plants grow to considerable sizes, being found up to 6m in length in some areas, but these are dwarfed by some Pacific species that may grow to 18m in length and to 2m in width. With Marine Research Measure funding, a study of the possibility of developing fast-growing hybrids of this species by crossing species from the Atlantic and Pacific is being carried out. We have growing in culture isolates of *A. esculenta* from Ireland, Scotland, France, Norway, and Atlantic Canada and other species from British Columbia and Japan. Species of this genus are ideal for cross-breeding studies as the males and females are tiny filamentous plants that are relatively easy to grow and propagate in culture under red light which stimulates reproduction in our growth rooms. Male and female reproductive structures occur on different plants so that we can put plants from one country in with those from another to see if they are sexually compatible.

To date, we have obtained interesting results with *A. praelonga*, a large species from Japan that co-operates sexually with *A. esculenta* from the Aran Islands and other Irish sites. The resulting Irish/Japanese progeny are grown initially in sample bottles agitated on a small shaker and their growth rates compared with plants that have resulted from self crosses. Preliminary results are very encouraging, with hybrid plants showing relatively high growth rates. We hope by this method to obtain sterile hybrids that will not reproduce in the wild so that we can introduce foreign genetic material without the fear that some sort of a tryffid will be introduced that will take over the west coast of Ireland.

While studies of these two food species are very promising, we must bear in mind that the market -for such sea-vegetables is very small and needs development and investment. Nutritionally, sea-vegetables are as good as any land-vegetable and are superior in their vitamin, trace element and even protein content. The increase in catholic food tastes in Europe should see greater utilisation of sea-vegetables in the next 20 years.

**Questions 1-5**

Classify the following features as characterizing

- A. brown algae
- B. green algae
- C. red algae
- D. brown and red algae

Write the correct letter A, B, C or D in boxes 1-5 on your answer sheet.

1. are being investigated as possible food sources.
2. are now called sea-vegetables.
3. make up more than half of all seaweed species.
4. are found on land and in freshwater.
5. are nearly all marine.

**Questions 6-9 Complete the table below.**

Choose NO MORE THAN THREE WORDS from Reading Passage 1 for each answer. Write your answers in boxes 6-9 on your answer sheet.

Types of brown algae	Himanthalia elongata	Alaria esculenta
Potential	food	food
Common name	thongweed	dabberlocks or 6 .....
Research funded	with a 7 ..... from Forbairt	by Marine Research Measure
Purpose	to examine growth and life cycle populations	creation of fast-growing 8 .....
Advantage	easy to collect	just right for 9 .....

**Questions 10-13** Answer the questions below. Choose NO MORE THAN THREE WORDS from the passage for each answer. Write your answers in boxes 10-13 on your answer sheet.

10. What does the red light in the growth rooms do?
11. What are initial growth rates shown to be?
12. What does the sea-vegetable market need?
13. What increasingly should lead to greater consumption of sea-vegetables?

Reading Passage 2

**Designing and shipping after the Restriction of Hazardous Substances (RoHS) directive**

1. Almost two months after the European Union's ban on the use of six environmentally unfriendly materials went into effect, designers have clear evidence that failure to meet the Restriction of Hazardous Substances (RoHS) directive means lost sales. Palm Inc. recently announced that its Treo 650 smart phone is no longer being shipped to Europe, since it doesn't meet RoHS requirements. And several Apple Computer Inc. products will not be sold in Europe for the same reason.
2. The EU directive, which took effect on 1<sup>st</sup> July, covers lead, mercury, cadmium, hexavalent chromium, polybrominated biphenyls and polybrominated diphenyl ethers. Electronics vendors worldwide are working to eliminate those substances from nearly all new products developed for the European market, while also adapting their manufacturing processes to a lead (Pb)-free environment.

3. But that is only the beginning. Other countries, including China, Taiwan and South Korea, and certain U.S. states are creating their own "green" or RoHS-like legislation. That means RoHS compliance must become an integral part of a designer's development process, with RoHS checks at each step: concept, development, prototype, first builds and volume production.
4. Major companies will run the gamut from finding component databases of qualified green components to taking due care to prove compliance and developing processes that allow for the higher-temperature requirements of Pb-free manufacturing. And for designers, those are just the tip of the iceberg. A host of technical and reliability issues remain to be sorted out in Pb-free board processing and soldering.
5. What it comes down to is what Ken Stanvick, senior vice president at Design Chain Associates, calls a lack of 'tribal knowledge' on design RoHS compliant systems. 'We had a great tribal knowledge when it came to dealing with leaded systems, but we haven't built up that same amount of knowledge for Pb-free,' he said. 'Every problem will be blamed on Pb-free until it's been worked out. We need to figure out tests that replicate more of the environment and different stresses that we're going to see in this new system.'
6. Manny Marcano, president and CEO of EMA Design Automation Inc. (Rochester, N.Y.), cited the impact of parts obsolescence, including the need to redesign older products and the resultant emphasis on component engineering at the expense of conceptual design. A key challenge is identifying RoHS design specifications as early as possible in the design process, he said.
7. But even before they get to that point, designers must understand whether they are designing a fully compliant product or one that's subject to some exemptions, said Robert Chinn, director for consultant firm PRTM (Mountain View, Calif.). 'This affects their design parameters,' he said. 'Previously, they looked at components based on size, performance, electrical parameters, features and functionality. Now they have to add on a new constraint, revolving around environmental compliance: Is it RoHS 6-compliant or is it RoHS 5-compliant?' (RoHS 6 components eliminate all six of the banned substances, while RoHS 5 models, because of exemptions, still contain lead.)
8. If designers do not take RoHS seriously, any country that can prove a product does not comply can levy fines against the vendor. That can cost market share, Marcano said, since noncompliant companies become noncompetitive. And then, not being prepared can mean belatedly diverting resources to RoHS compliance, causing missed market opportunities.
9. But many industry observers believe smaller and medium-size companies will continue to be complacent about the RoHS transition until some major company is cited for non-compliance. 'When that happens, there will be an earthquake throughout the industry, and it will wake up every design engineer,' said Steve Schultz, director of strategic planning and communications at Avnet Logistics and program manager for the distributor's compliance efforts for RoHS in the Americas.
10. 'The product developer's RoHS concerns center on the fear of lost revenue - from a product ban, a customer who demands a RoHS-compliant product that the company doesn't have, or competition', said Harvey Stone, managing director for consultancy GoodBye Chain Group (Colorado Springs, Colo.). 'With price, quality and service being relatively equal, a savvy customer is going to choose a RoHS-compliant product,' he said.
11. Meanwhile, designers are looking over their shoulders at several other - and potentially stricter - environmental regulations in the pipeline. These include the EU's Registration, Evaluation and Authorization of Chemicals legislation, which could restrict the use of thousands of chemicals, and its Energy- using Products (EuP) directive, which will initially target energy-efficiency requirements.

#### Questions 14-17

Look at the following people and the list of statements below. Match each person with the correct statement. Write the correct letter A-G in boxes 14-17 on your answer sheet.

14. Manny Marcano
15. Harvey Stone
16. Steve Shultz
17. Ken Stanvick

#### List of Statements

- A. believes that the ED directive requires no action
- B. claims that old products need to be redesigned
- C. claims that customers will want a RoHS compliant product
- D. states that many products will be RoHS exempt
- E. is involved in planning and communications
- F. predicts that design engineers will like RoHS
- G. claims that more knowledge about Pb-free systems is needed

**Questions 18-24**

Complete the summary using the list of words A-P below. Write the correct letter A-P in boxes 18-24 on your answer sheet.

The EU has banned the use of six materials that are 18.....to the environment. This means that if designers do not meet the Restriction of Hazardous Substances (RoHS) directive, sales will 19.....Similar legislation is being put together around the world, which indicates that RoHS compliance needs to become a 20.....part of a designer's development process. RoHS checks, at every step from concept to mass production, is also a necessity. But 21.....technical and reliability problems remain to be 22.....Previously, the performance etc. of components were 23.....but now a new 24.....needs to be taken into account: environmental compliance.

- A. requirement
- B. friendly
- C. hostile
- D. increase
- E. big
- F. basic
- G. insignificant
- H. numerous
- I. variety
- J. decline
- K. solved
- L. important
- M. idea
- N. small
- O. recognised
- P. need

**Questions 25-27**

Do the following statements agree with the information in Reading Passage 2?

- TRUE           if the statement agrees with the information  
 FALSE         if the statement contradicts the information  
 NOT GIVEN   if there is no information about the statement

25. Countries can impose fines on the sellers of products that do not comply with RoHS.

26. Smaller companies are taking the changeover to RoHS seriously.

27. The Energy-using directive will be introduced in the very near future.

**Reading Passage 3**

Reading Passage 3 has seven paragraphs A-G. Choose the correct heading for paragraphs A and C-G from the list of headings below. Write the correct number, i-ix, in boxes 28-33 on your answer sheet.

**List of Headings**

- i. Some criticisms of video-conferencing
- ii. The future of conferencing by video
- iii. The transmission of education to remote areas
- iv. The first stages of video-conferencing
- v. The necessity of having two TVs
- vi. How video-conferencing can benefit organizations
- vii. How video-conferencing became more accessible to the general public
- viii. The various pieces of equipment needed
- ix. The lack of exploitation of video-conferencing in education



Example Paragraph B

Answer vii

- 28. Paragraph A
- 29. Paragraph C
- 30. Paragraph D
- 31. Paragraph E
- 32. Paragraph F
- 33. Paragraph G

## **Seeing the future in with video-conferencing**

- A. Video-conferencing (or Video teleconferencing-VTC) as a means of communication intra- and inter-business has essentially been possible since the dawn of television. But the early systems, first demonstrated in 1968, were in fact so prohibitively expensive and of such poor picture quality that they were not viable applications for general public use.
- B. However, in the 1980s, digital telephone networks like ISDN began to proliferate, so that by the 1990s the decrease in cost brought the equipment necessary for video-conferencing within the reach of the masses. The 1990s also saw the arrival of IP (Internet Protocol) based video-conferencing with more efficient video compression technologies being introduced, thus permitting desktop, or personal computer (PC)-based videoconferencing. VTC had come on the scene in a big way as free services, web plugins and software, such as NetMeeting, and MSN Messenger, Skype and others brought cheap, albeit low quality, VTC to the public at large.
- C. Video-conferencing has been disparaged for the lack of eye-contact that can affect the efficacy of the medium and for the fact that participants can be camera conscious. But these obstacles are not insurmountable. The size of modern televisions along with the vast improvement in picture quality as a result of the arrival of the digital age has enhanced the potential of the latest video-conferencing equipment, going somewhat towards solving the former problem. Early studies by Alphonse Chapanis found that the addition of video hindered rather than improved communication. However, as with video and sound recording of meetings, interviews etc, awareness of the presence of the technology diminishes with time to the point that its presence is not felt. A further drawback common to all technology is the ever present possibility of technical hitches. But in the end video-conferencing is no different from any electronic device like a PC or a telephone and so in time, any problems will be ironed out.
- D. Conferencing by video has enhanced the performance of different organizations through its efficiency and effectiveness, saving both time and money for businesses and, in this carbon-conscious age, by the reduction in the environmental cost of business travel from one corner of the world to another. These apart, video-conferencing has an immediacy that is difficult to challenge. It is now essential in any work situation where organizations with employees on different sites or in different parts of the globe can contact each other rapidly. Like a telephone line permanently connected it is easy to dial up a colleague in seconds anywhere in the world.
- E. And what about the equipment? The equipment for video-conferencing is relatively straightforward to use. It has, in fact, been commonplace in the news media for a number of years as corporations have broadcast live from the back of a truck or van in news hotspots around the world. Two ISDN lines are needed at each location: one for video output and the other for video input; a high quality camera with omni directional microphones or microphones which can be hand-held, clipped on or central are required; and for data transfer a LAN is also needed. And, of course, a television screen at each end is essential.
- F. The potential use of video-conferencing in the educational field has yet to be fully exploited. In this day and age when academic institutions are supposed to be more revenue conscious and

much more flexible, video-conferencing could be employed to bring business into the educational field and vice versa. The system can also be used to take expertise anywhere in the world. It is no longer necessary for experts to travel vast distances for conferences or to teach. In certain areas, say remote islands like the Outer Hebrides in Scotland or the Cape Verde Islands off West Africa, where it may be difficult to find teachers in specialist subjects like languages, videoconferencing is a perfect way to bring education within the reach of everyone. Video-conferencing is certainly not a panacea for every problem, not an end in itself, but a useful tool that can complement rather than supplant existing teaching methods.

- G. Like the electronic or smart whiteboard, whose introduction in the classroom has met with resistance, video-conferencing may take some time to become mainstream, if ever. But, perhaps with the mounting concern about our carbon footprint, the environment will ultimately be the biggest spur. A sobering thought is whether classrooms and offices of the future will consist solely of TV screens.

**Questions 34-36** Choose the correct letter A, B, C or D.

Write your answers in boxes 34-36 on your answer sheet.

34. Video-conferencing was not common initially because of
- the cost and poor image quality.
  - poor advertising and marketing.
  - the lack of skilled technicians.
  - constant electronic failures.
35. Video-conferencing became more practical on personal computers once
- the Internet became more widespread.
  - the picture quality became perfect.
  - the software became free for the general public.
  - D video compression technology worked better.
36. Video-conferencing has been attacked for
- several problems that cannot be solved.
  - the lack of large TV screens.
  - there not being direct eye contact.
  - the failure of new digital technology.

**Questions 37-39** Choose THREE letters A-F.

Write your answers in boxes 37-39 on your answer sheet. NB Your answers may be given in any order.

Which THREE of the following statements are true of video-conferencing?

- It is cost-effective for businesses to use.
- Operating VC equipment is not complicated.
- It will solve many problems in the classroom.
- More people now have the necessary skills to use video-conferencing.
- Modern equipment rarely breaks down.
- People in remote areas can have expertise taken to them.

**Question 40**

Choose the correct letter A, B, C or D.

Write your answer in box 40 on your answer sheet.

40 The writer concludes that the success of video-conferencing in the classroom

- is less likely than that of the whiteboard.
- will certainly be short-lived.
- may be linked to many unknown factors.
- may finally depend on the environment.

## Testbuilder 2 test 3

## Reading Passage 1

**CAVES**

1. Caves are natural underground spaces commonly those into which man can enter. There are three major types: the most widespread and extensive are those developed in soluble rocks, usually limestone or marble, by underground movement of water; on the coast are those formed in cliffs generally by the concentrated pounding of waves along joints and zones of crushed rock; and a few caves are formed in lava flows, where the solidified outer crust is left after the molten core has drained away to form rough tunnels, like those on the small basalt volcanoes of Auckland.
2. Limestone of all ages, ranging from geologically recent times to more than 450 million years ago, is found in many parts of New Zealand, although it is not all cavernous. Many caves have been discovered, but hundreds still remain to be explored. The most notable limestone areas for caves are the many hundreds of square kilometres of Te Kuiti Group (Oligocene) rocks from Port Waikato south to Mokau and from the coast inland to the Waipa Valley - especially in the Waitomo district; and the Mount Arthur Marble (upper Ordovician) of the mountains of northwest Nelson (fringed by thin bands of Oligocene limestone in the valleys and near the coast).
3. Sedimentary rocks (including limestone) are usually laid down in almost horizontal layers or beds which may be of any thickness, but most commonly of 5-7.5 cm. These beds may accumulate to a total thickness of about a hundred metres. Pure limestone is brittle, and folding due to earth movements causes cracks along the partings, and joints at angles to them. Rain water percolates down through the soil and the fractures in the underlying rocks to the water table, below which all cavities and pores are filled with water. This water, which is usually acidic, dissolves the limestone along the joints and, once a passage is opened, it is enlarged by the abrasive action of sand and pebbles carried by streams. Extensive solution takes place between the seasonal limits of the water table. Erosion may continue to cut down into the floor, or silt and pebbles may build up floors and divert stream courses. Most caves still carry the stream that formed them.
4. Caves in the softer, well-bedded Oligocene limestones are typically horizontal in development, often with passages on several levels, and frequently of considerable length. Gardner's Gut, Waitomo, has two main levels and more than seven kilometres of passages. Plans of caves show prominent features, such as long, narrow, straight passages following joint patterns as in Ruakuri, Waitomo, or a number of parallel straights oriented in one or more directions like Te Anaroa, Rockville. Vertical cross sections of cave passages may be tall and narrow following joints, as in Burr Cave, Waitomo; large and ragged in collapse chambers, like Hollow Hill, Waitomo (233m long, 59.4m wide, and 30.48m high); low and wide along bedding planes, as in Luckie Strike, Waitomo; or high vertical water-worn shafts, like Rangitaawa Shaft (91 m). Waitomo Caves in the harder, massive Mount Arthur Marble (a metamorphosed limestone) are mainly vertical in development, many reaching several hundred metres, the deepest known being Harwood Hole, Takaka (370m).
5. The unique beauty of caves lies in the variety of mineral encrustations which are found sometimes completely covering walls, ceiling, and floor. Stalactites (Gk. stalaktos, dripping) are pendent growths of crystalline calcium carbonate (calcite) formed from solution by the deposition of minute quantities of calcite from percolating ground water. They are usually white to yellow in colour, but occasionally are brown or red. Where water evaporates faster than it drips, long thin straws are formed which may reach the floor or thicken into columns. If the source of water moves across the ceiling, a thin drape, very like a stage curtain, is formed. Helictites are stalactites that branch or curl. Stalagmites (Gk. stalagmos, that which dripped) are conical or gnarled floor growths formed by splashing, if the water drips faster than it evaporates. These may grow toward the ceiling to form columns of massive proportions. Where calcite is deposited by water spreading thinly over the walls or floor, flowstone is formed and pools of water may build up their edges to form narrow walls of rimstone. Gypsum (calcium sulphate) is a white cave deposit of many crystal habits which are probably dependent on humidity. The most beautiful form is the gypsum flower which extrudes from a point on the cave wall in curling and diverging bundles of fibres like a lily or orchid.

**Questions 1-3 Complete the summary.**

Choose ONE WORD ONLY from the passage for each answer.

There are several 1.....of caves with the most common and largest being located in limestone or marble. Coastal caves are created in cliffs usually by waves. In lava flows, the solidified outer crusts that remain once the molten core has drained away also form 2.....Limestone is to be found all over New Zealand, but not all of it contains caves. While many caves are known, there are large numbers that have yet to be uncovered. The main 3.....for limestone caves are Te Kuiti Group rocks.

**Questions 4-8 Complete the flow-chart.**

Choose ONE WORD ONLY from the passage for each answer.

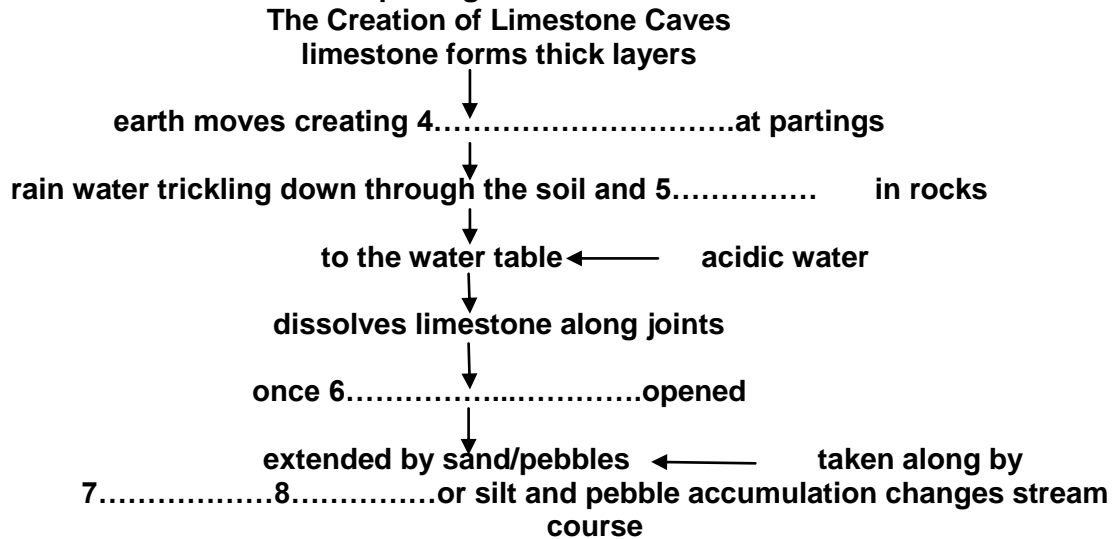

**Questions 9 and 10 Choose TWO letters A-E.**

Which TWO of the following features of caves in the softer limestones are mentioned in the text?

- A. they are often long
- B. they are all at least 7.2km long
- C. most of them are vertical
- D. they only ever have one passage
- E. they are characteristically horizontal

**Questions 11-13**

Do the following statements agree with the information in Reading Passage I? Write

- TRUE if the statement agrees with the information
- FALSE if the statement contradicts the information
- NOT GIVEN if there is no information about the statement

- 11. The limestone found in New Zealand is more than 450 million years old.
- 12. Stalactites are more often white to yellow than brown or red.
- 13. Stalagmites never grow very large.

**Reading Passage 2**

1. Left- or right-handed bath water? This seems a silly question, but it was the subject of a serious scientific investigation sponsored by the Daily Mail in 1965. The investigation showed that the direction water swirls down the plug-hole vortex depends on which side of the Equator you are.
2. As for homo sapiens, between 5 and 30% of the population are estimated to be left-handed, with more males than females,' although .in one test, 95% of foetuses were found to suck their right thumb in the womb. The general consensus of opinion is that left-handedness is determined by a dominant right cerebral hemisphere controlling the left side of the body, and vice versa. Hereditary factors have been ruled out. So too have earlier theories concerning the

need for soldiers to shield their hearts, and the desirability of learning to use Stone Age tools and implements with the hand they were designed for, as well as Plato's idea that it all boiled down to which arm a baby was cradled with. However, the almost universal human preference for dextrality, or right-handedness, remains a mystery.

3. Prejudice against the left hand dates back to ancient times and is so entwined with religious beliefs and superstitions that it still exists today, in everyday speech. Sinister, the Latin for left hand, means 'suggestive of evil' in English, while the French gauche is awkward, or clumsy. Left itself derives from Anglo Saxon *lef* (weak and fragile). The nonjudgmental term southpaw, by contrast, originates from the Chicago baseball stadium where pitchers faced west, so the pitching arm of a lefthander is to the South.
4. Other negative terms include pen pushers, while a left-handed compliment is actually an insult. Thomas Carlyle, who described right-handedness as the oldest institution in the world, introduced the political concept of 'left' in his work on the French Revolution - in the 1789 Paris Assembly the nobles sat on the right, opposite the radicals.
5. Associations with luck also go back to early history. The ancient Greek and Roman augurs foretold the future from bird-flight. While the former faced North, with the propitious sunrise side to their right, the latter, before changing later, when sinister took on its' ominous meaning, looked southward, so the left was for good omens.
6. Superstitions world-wide reflect this bias. In Morocco, as in many countries, an itchy left palm means losing money, and a twitching left eyelid denotes the death of a relative or sorrow, whereas the right side has felicitous indications. We throw salt over our left shoulder to thwart the demons creeping up on us, but bless with the right hand. One pours wine with this hand and passes it round the table clockwise, the direction of the sun.
7. Our relatives, the primates, appear to be ambidextrous, or able to use both hands, although gorillas have heavier left arms seemingly due to greater utilization. Aristotle observed that crabs and lobsters had larger right claws. Rats are 80% dextral, yet polar bears are believed to be left-pawed. Flat fish provide interesting data: in northern seas plaice and sole have their eyes and colour on the right side, but tropical halibut are the other way round. If this is to do with light and sun rotation, it may explain why Indian Ocean sole are reversed, but not why northern halibut are' just as sinistral as their southern cousins. In the plant kingdom, honeysuckle is a rare example of a left-handed climber that twines anticlockwise, or widdershins!
8. Although we live in a more tolerant age, not so long ago in the UK youngsters were forced to use their right hand, 'to learn the value of conformity' (A. N. Palmer), often resulting in the stuttering speech defects common in 'switched sinistrals' like George VI. In the 1950s the American psychiatrist Abram Blau accused left-handed children of infantile perversity and a stubborn refusal to accept dextrality.
9. Not all experts were so anti- sinistral, however. The 17th century Norfolk scholar Sir Thomas Browne wrote of the prejudices against left handedness, but accepted that a small proportion of people would always be so and saw no reason to prevent them. Apart from being considered difficult, anti-social troublemakers, left-handers have also been thought to be artistic, creative and gifted.
10. Famous lefties include Leonardo da Vinci, Michelangelo, Benjamin Franklin, Bill Clinton, Joan of Arc, Lewis Carroll, Paul McCartney, Jimi Hendrix, , Jean Genet, Beethoven and many others.
11. Finally, in defence of all sinistrals, if the left side of the body is really controlled by the right hemisphere of the brain, then left-panders are the only people in their right minds!

**Questions 14-18** Choose the correct letter A, B, C or D.

14. The direction of water going down the plug-hole
  - A. is not related to where you are.
  - B. is independent of the side of the Equator you are on.
  - C. is linked to the side of the Equator you are on.
  - D. was first discovered by the Daily Mail in the 1950s.
15. In determining left-handedness, hereditary factors are generally considered
  - A. as important.
  - B. as having no impact.
  - C. as being a major influence.
  - D. as being the prime cause.

16. The reason why
- almost everyone is right-handed is unknown.
  - some people are right-handed is ambiguous.
  - Plato worked out the mystery of left-handedness is not known.
  - many people are right-handed is now clear.
17. The word 'southpaw' is
- an Anglo-Saxon term.
  - not a negative term.
  - suggestive of evil.
  - a negative term.
18. The left was connected with
- being unclean by the Greeks.
  - goodness by the French.
  - fortune and bird-flight by many cultures.
  - good fortune in ancient Greece and Rome.

**Questions 19-22**                      **Answer the questions below.**

Choose NO MORE THAN TWO WORDS from the passage for each answer.

- Who was the originator of the political concept of left?
- What did the ancient Romans use to predict the future?
- What does an itchy palm in the left hand mean?
- In which direction is wine passed round the table?

**Questions 23-26**                      **Complete each sentence with the correct ending A-G.**

- Gorillas, unlike other primates,
- Fish colour and eye position
- Most plant climbers
- In the past some experts

- |   |
|---|
| <ol style="list-style-type: none"> <li>appear to have been against left-handedness.</li> <li>are usually the same in both hemispheres.</li> <li>are apparently not always dependent on hemisphere.</li> <li>seem to have difficulty using both hands.</li> <li>looked on left-handedness with indifference.</li> <li>tend to grow clockwise rather than anti-clockwise.</li> <li>seem to use their left-hand more.</li> </ol> |
|---|

**Question 27**                      **Choose the correct letter A, B, C, D or E.**

Which of the following is the most suitable title for Reading Passage 2?

- Left-handedness and primates
- A defence of right-handedness
- A defence of left-handedness
- Left-handedness and good luck
- Left-handedness and bad luck

Reading Passage 3

**PHYSICIAN, RULE THYSELF!**

*Professions and self-regulation*

- A. When is an occupation a profession? There appears to be no absolute definition, but only different ways of looking at the issue, from historical, cultural, sociological, moral, political, ethical or philosophical viewpoints. It is often said that professions are elites who undertake specialized, selfless work, in accordance with ethical codes, and that their work is guaranteed by examination and a licence to practise. In return, however, they request exclusive control over a body of knowledge, freedom to practise, special rewards and higher financial and economic status.

- B. The public needs experts to offer them specialist advice, but because this advice is specialized they are not in a position to know what advice they need: this has to be defined in conversation with the professional. Professional judgement could be at odds with client satisfaction since the latter cannot then be "the chief measure of whether the professional has acted in a trustworthy fashion." Professional elites have negative potential: to exploit their power and prestige for economic goals; to allow the search for the necessary theoretical or scientific knowledge to become an end in itself; to lose sight of client well-being in the continuing fragmentation of specialist knowledge.
- C. Professions in different cultures are subject to different levels of state intervention, and are shaped by this. In England our relatively weak state and the organic growth of professional groups, many of them licensed by Royal Charter, means that regulation became an arrangement among elites. Similarly, in the US. where liberal market principles have had a free rein, academic institutions have had more influence than the state in the development of the professions. By contrast, in many European countries the state has defined and controlled the market for the professions since the late eighteenth and early nineteenth centuries. In all cases, the activities of the professions affect public interest, and so the state has a legitimate interest in them.
- D. In general, the higher the social status of a profession the greater the degree of public trust in it, and the more freedom to operate it enjoys. There are, however, certain features which appear to be common to most, if not all, professions. In addition to a specialised knowledge base, it appears that there is an agreed set of qualifications and experience which constitutes a licence to practise. There is also frequently an agreed title or form of address, coupled with a particular, often conservative, public image, and an accepted mode of dress. Standards are maintained mainly through self-regulatory bodies. Also, financial rewards may be increased through private practice.
- E. Within different cultures, and at different times, the relative status of different professions may vary. For example, in Western Europe, the status of politicians has been in long-term decline since the middle of the twentieth century. Teachers would appear to have higher status in France and Italy than in the UK, where medicine and the law have traditionally been the 'elite professions'.
- F. The higher a profession's social status the more freedom it enjoys. Therefore, an occupation wanting to maintain or improve its status will try to retain as much control as possible over its own affairs. As in so many other areas, socio-cultural change has affected the professions considerably in recent years. Market forces and social pressures have forced professionals to be more open about their modes of practice. In addition, information technology has enabled the public to become much better informed, and therefore more demanding. Moreover, developments in professional knowledge itself have forced a greater degree of specialisation on experts, who constantly have to retrain and do research to maintain their position.
- G. Self-regulation then becomes an even more important thing for a profession to maintain or extend. But in whose interests? Is self-regulation used to enable a profession to properly practise without undue interference, or is it used to maintain the status of the profession for its own ends? Is it used to enable those with appropriate education and training to join the profession? Another question that needs to be answered is whether self-regulation restricts access so that the profession retains its social and economic privileges? Or again is it used to protect clients by appropriately disciplining those who have transgressed professional norms, or to protect the public image of the profession by concealing allegations that would damage it?
- H. These are all questions which the medical profession in the UK has recently had to address, and which remain the subject of continuing debate. One thing is clear, however: the higher a profession's status, the better equipped it is to meet these challenges.

### Questions 28-32

Reading Passage 3 has eight paragraphs A-H. Which paragraph contains the following information?

28. how professionals have adjusted to socio-cultural developments
29. the typical characteristics that a profession has
30. the role that is played by governments in different countries
31. a description of the relationship between professionals and their clients
32. the fact that there is no clear definition of what a profession is

**Questions 33-37 Complete the sentences.**

Choose NO MORE THAN THREE WORDS from the passage for each answer.

- 33. Professionals cannot always ensure that the.....given will satisfy the client.
- 34. Liberal market principles in the US have meant that the state has had less impact on the development of the professions than.....
- 35. An agreed set of qualifications and experience give professionals a.....
- 36. Over the past 50 years or so, the status of politicians has been in.....
- 37. There is a doubt as to whether.....is a mechanism to safeguard a profession's social and economic privileges.

**Questions 38-40 Complete the table.**

Choose NO MORE THAN TWO WORDS from the passage for each answer. Write your answers in boxes 38-40 on your answer sheet.

**Impact of socio-cultural change on professions**

Factors	Implications
Various public influences	professionals 38 ..... about work.
Modern technology	people more knowledgeable and so more 39 .....
Progress in professional knowledge	a greater degree of 40 ..... needed



## Testbuilder 2 Test 4

## Reading Passage 1

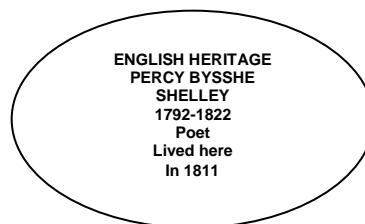
English Heritage Blue Plaques Scheme 2

- A. The blue plaques scheme has been running for over 140 years and is one of the oldest of its kind in the world. The idea of erecting 'memorial tablet was first proposed by William Ewart MP in the House of Commons in 1863. It had an immediate impact on the public imagination, and in 1866 the Society of Arts (later Royal Society of Arts) founded an official plaques scheme. The Society erected its first plaque - to the poet Lord Byron - in 1867. In all, the Society of Arts erected 35 plaques; today, less than half of them survive, the earliest of which commemorates Napoleon III (1867). In 1901, the plaques scheme was taken over by London County Council (LCC), which erected nearly 250 plaques over the next 64 years and gave the scheme its popular appeal. It was under the LCC that the blue plaque design as we know it today was adopted, and the selection criteria were formalised. On the abolition of the LCC in 1965, the plaques scheme passed to the Greater London Council (GLC). The scheme changed little, but the GLC was keen to broaden the range of people commemorated. The 262 plaques erected by the GLC include those to figures such as Sylvia Pankhurst, campaigner for women's rights; Samuel Coleridge-Taylor, composer of the Song of Hiawatha; and Mary Seacole, the Jamaican nurse and heroine of the Crimean War. Since 1986, English Heritage has managed the blue plaques scheme. So far, English Heritage has erected nearly 300 plaques, bringing the total number to over 800.
- B. English Heritage receives about 100 suggestions for blue plaques each year, almost all of which come from members of the public. The background of each case is very different. Each nominated person has to meet basic selection criteria before they can be considered. Most importantly, they must have been dead for 20 years or have passed the centenary of their birth, whichever is the earlier. This delay allows a person's reputation to mature and ensures that their fame is long-lasting.
- C. English Heritage's Blue Plaques Panel - representatives of various disciplines from across the country - considers all the suggestions which meet the basic criteria; on average, around 1 in 3 proposals are accepted. If a figure is rejected, proposers must wait a further 10 years before their suggestion can be considered again. Detailed research is carried out into the surviving addresses of shortlisted candidates, using sources such as autobiographies, electoral registers and post office directories.
- D. As only one plaque is allowed per person, the house to be commemorated has to be chosen very carefully. Factors which are considered include length of residence and the accomplishments of a candidate during the relevant years. A significant place of work can also be considered.
- E. Before a plaque can be erected, the owners and tenants of the building in question have to give their consent. Where listed buildings are involved, Listed Building Consent is sought from the relevant local authority. If such consents are granted, the plaque is designed, and then produced by a specialist manufacturer. It is normally ready within about two months. Plaques are set into the fabric of the building, flush with the wall face. The cost of plaque manufacture and installation are borne entirely by English Heritage. In all, it can take between 2 and 5 years from the initial suggestion to the erection of a plaque.
- F. The exact form of the blue plaque, as we see it now, was a relatively late development, though certain guiding principles had been in place from the outset. The earliest plaques, erected in 1867, were blue. Their format, a circle with the name of the Society of Arts worked into a pattern around the edge, was used consistently by the Society over its 35 years of management.
- G. Manufacture of each plaque is undertaken by the mixing and pouring of a thick clay slip into a casting mould. When sufficiently dry, the cast is removed and the outline of the inscription and border is piped onto the face of the plaque and filled with white glaze. Blue glaze is then applied to the background before firing. This process produces gently raised characters and border, a

unique feature of English Heritage plaques. After firing, plaques usually have a thickness of 2 inches (50mm) and a final diameter of 19.5 inches (495mm), although smaller diameter plaques are sometimes used to meet special circumstances.

- H. Plaques have been found to be extremely durable and have an almost indefinite life expectancy. Similar plaques erected by the Society of Arts have lasted, perfectly legible, for over one hundred years. Due to the slightly domed design, they are self-cleansing and require virtually no maintenance.

© Emily Cole, English Heritage

### Questions 1-6

Reading Passage 1 has eight paragraphs A-H. Which paragraph contains the following information? Write the correct letter, A-H, in boxes 1-6 on your answer sheet.

1. the toughness of the plaques
2. the length of time it takes to produce a plaque
3. the way the Blue Plaques Panel functions
4. the conditions which need to be met in each case
5. the reasons behind selecting a house to be honoured
6. how the Blue Plaques scheme first started

### Questions 7-10 Complete the diagram below.

Choose NO MORE THAN TWO WORDS AND/OR A NUMBER from the passage for each answer.

#### A Blue Plaque

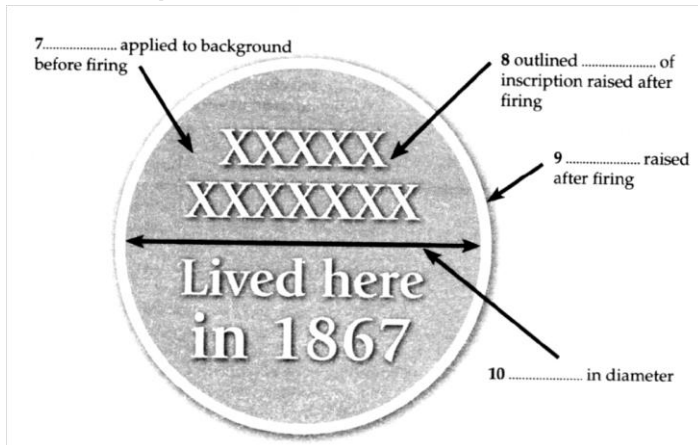

### Questions 11-13

Do the following statements agree with the information in Reading Passage 1? Write

TRUE if the statement agrees with the information  
 FALSE if the statement contradicts the information  
 NOT GIVEN if there is no information about the statement

11. The GLC did not erect as many plaques as English Heritage has.
12. Rejected proposals are given a detailed explanation of their refusal.
13. The form of the blue plaque has not changed since it was first made.

**Reading Passage 2****Questions 14-19**

Reading Passage 2 has eight paragraphs A-H. Choose the correct heading for paragraphs B and D-H from the list of headings below. Write the correct number, i-xi, in boxes 14-19 on your answer sheet.

**List of Headings**

- i. Testing acquired knowledge
- ii. The way future performance is forecast through testing
- iii. The Minnesota Multiphasic Personality Inventory
- iv. Software tools in research explained
- v. The use of a five-point scale in testing
- vi. A test used to obtain a summary score of an individual's intelligence
- vii. The method most widely used by psychologists in various situations
- viii. Subjective interests employed to predict future behaviour
- ix. The different classes of standardized tests
- x. The importance of prior learning in tests
- xi. Information gathered by self-reporting

Example	Paragraph A	Answer	iv
---------	-------------	--------	----

14. Paragraph B			
-----------------	--	--	--

Example	Paragraph C	Answer	i
---------	-------------	--------	---

15. Paragraph D			
-----------------	--	--	--

16. Paragraph E			
-----------------	--	--	--

17. Paragraph F			
-----------------	--	--	--

18. Paragraph G			
-----------------	--	--	--

19. Paragraph H			
-----------------	--	--	--

- A. The software tools of research are typically more abundant than hardware tools in the social sciences. Software is usually thought of as meaning computer programs that tell the hardware what to do, but any tool not related to a physical device can be considered software. Included in this category are published tests and questionnaires.
- B. Often researchers want to gather information related to a general area such as personality or intelligence. For these instances, the use of a standardized test may be the best choice. With already published tests you can be sure of both validity and reliability and can save a lot of time that might otherwise be spent on test construction. Standardized tests can be classified into five main categories: achievement, aptitude, interest, personality, and intelligence.
- C. Achievement tests are designed specifically to measure an individual's previously learned knowledge or ability. They are available for many topic areas related to psychology, education, business, and other fields. Achievement tests require that prior learning take place and that this learning be demonstrated in order to pass.
- D. Aptitude tests attempt to predict an individual's performance in some activity at some point in the future. They do not require any specific prior learning although basic knowledge related to reading and writing is usually required and some preparation, such as studying up on math formulas or sentence structure, can be helpful. A well-known example of this type is the Scholastic Achievement Test (SAT), designed to predict future college performance.
- E. Interest inventories also require only general knowledge but no preparation is needed. These tests look at an individual's subjective interests in order to make predictions about some future behavior or activity. Perhaps the most used interest inventory is the Strong Interest Inventory, which compares interests related to specific careers in order to help guide an individual's career path. Endorsed interests are compared with the interests of successful individuals in various fields and predictions are made regarding the test-taker's fit with the various career fields.
- F. Typically designed to assess and diagnose personality and mental health related disorders, personality tests are used extensively by psychologists in clinical, educational, and business related settings. By far the most widely used test of this type is the Minnesota Multiphasic Personality Inventory, Second Edition (MMPI-2), which compares an individual's responses on a series of true-false items to those suffering from various mental disorders such as depression, schizophrenia, and anxiety. The theory behind the test argues that if you endorse

items similar to the items endorsed by those with depression, for example, then the chances that you are also depressed increases.

- G. Intelligence tests could be classified as aptitude tests since they are sometimes used to predict future performance. They could also be classified as personality tests since they can be used to diagnose disorders such as learning disabilities and mental retardation. However, because of their limited scope, we will place them in their own category. The purpose of an intelligence test is to attain a summary score or intelligence quotient (IQ) of an individual's intellectual ability. Scores are compared to each other and can be broken down into different subcategories depending on the intelligence test used. The most commonly used tests of this type are the Wechsler Scales, including the Wechsler Adult Intelligence Scale (WAIS), the Wechsler Intelligence Scale for Children (WISC), and the Wechsler Preschool and Primary Scale of Intelligence (WPPSI).
- H. Self-response questionnaires are a great way to gather large amounts of information in a relatively short amount of time. A questionnaire, similar to a survey you might see on a web page, allows subjects to respond to questions, rate responses, or offer opinions. Their responses can then be used to place them in specific categories or groups or can be compared to other subjects for data analysis. A concern with self report, however, is the accuracy of the responses. Unlike direct observation, there is no way of knowing if the subject has told the truth or whether or not the question was understood as intended. There are several different methods for gathering information on a questionnaire or survey, including a Likert scale, the Thurstone technique, and the semantic differential. The Likert scale is a popular method used in surveys because it allows the researcher to quantify opinion based items. Questions are typically grouped together and rated or responded to based on a five-point scale. This scale typically ranges in order from one extreme to the other, such as (1) very interested; (2) somewhat interested; (3) unsure; (4) not very interested; and (5) not interested at all. Items that might be rated with this scale representing the subject's level of interest could include a list of careers or academic majors, for example.

### Questions 20-23

Choose the correct letter A, B, C or D. Write your answers in boxes 20-23 on your answer sheet.

20. Tests that are already on the market
- need some form of reconstruction.
  - fail to ensure validity and reliability.
  - guarantee validity and reliability.
  - waste large amounts of time.
- 21 Some knowledge of reading and writing
- is commonly not necessary in aptitude tests.
  - is normally a requirement in aptitude tests.
  - is less important in aptitude tests than other tests.
  - is as important as prior learning in aptitude tests.
- 22 With interest inventories, subjective interests are examined to
- test people's general knowledge.
  - help people change their career.
  - compare individual's backgrounds.
  - forecast future behaviour or activity.
- 23 Intelligence tests could come under aptitude tests
- because they can be used to forecast future performance.
  - since they are not used very widely.
  - as they can be broken down into different sub-groups.
  - because they are sometimes used to diagnose learning disabilities.

### Questions 24-26

Do the following statements agree with the claims of the writer in Reading Passage 2?

- YES if the statement reflects the claims of the writer  
 NO if the statement contradicts the claims of the writer  
 NOT GIVEN if it is impossible to say what the writer thinks of this

24. The Wechsler Scales are the only type of intelligence test now used.

25. Where large quantities of data need to be collected fairly quickly self-response questionnaires work well.

26. The Likert Scale ensures greater accuracy than other techniques.

#### Question 27

Choose the correct letter A, B, C or D.

27 Which of the following is the most suitable heading for Reading Passage 2

- A. Different types of intelligence test
- B. How personality can be tested
- C. The importance of aptitude tests
- D. The various software tools of research

#### Reading Passage 3

### Much ado about almost nothing

*The public outcry over genetically modified food offers several lessons for those working and investing in nanotechnology*

#### Profit of doom

1. "THE time for discussion of the rights and wrongs of GM crops has passed. Intense and consistent economic sabotage and intimidation are what will make the commercialisation of GM crops an unattractive option."
2. Words like these, from an article in the current edition of Earth First!, a radical environmental journal, send shivers down the spines of those involved in commercialising biotechnology. The strength of public disapproval of genetically modified organisms (GMOs) was a shock and a surprise to most of those involved. Now, some people are wondering whether nanotechnology - a term that covers the manipulation of matter at scales of a millionth of a millimetre - could be in for similar treatment and, if so, whether there are lessons that its protagonists can learn from the public backlash against biotechnology.
3. In a neglected corner, amid thousands of participants at a Nanotech conference held in Boston last week, Jeffrey Matsuura, a law professor at the University of Dayton, in Ohio, stood next to his unprepossessing poster of his work. His warning, however, was pertinent to everyone there - especially the investors who were scouring the conference for opportunities. And this is that several of the factors that created a public backlash against biotechnology are already at work within nanotechnology. Dr Matsuura says that biotechnologists assumed that the public would quickly recognise and appreciate biotech's potential for improving the quality of life. Instead, the risks captured the attention of the media and much of the general public. Well-fed European consumers met the suggestion of cheaper food, in particular, with scepticism. Many felt that the gains would accrue to the companies which had developed GMOs, while the risks of growing and consuming the crops would be taken on by the public.
4. Dr Matsuura believes that public perception of nanotechnology is developing along a similar track. Like those of biotechnology, the first applications of nanotechnology will bring little obvious benefit to consumers. Better, cheaper materials, and hidden manufacturing efficiencies that benefit producers first, are redolent of the 'advantages' of biotech - namely reduced applications of agricultural chemicals, which help to keep the cost down while raising yields. Obvious consumer benefits, such as improvements in medicine, are further away.
5. This should not matter - consumers do benefit eventually, even from cost savings. And yet, in alliance with a feeling that there are hazards involved, an absence of immediate benefits could turn public opinion against nanotech quite rapidly. And potential hazards there are. Concerns over out-of-control, selfreplicating 'nanobots' that would eventually consume and transform the entire planet into a 'grey goo' are absurd. And yet, it is true that novel 'nanoparticles' might have real toxicological risks.
6. Nanoparticles are so small that, if inhaled, they could become lodged in the lungs. In theory, they are small enough to enter living cells and accumulate there. And in January Ken Donaldson, a professor of respiratory toxicology at the University of Edinburgh, told a Royal Institution seminar in London that, once inhaled, ultrafine carbon particles can move to the brain and blood.
7. There are already several products that use nanoparticles already on the market, such as sunscreen and car parts. Though all this may sound alarming, people are already exposed to

nanoparticles of many different kinds, and have been throughout history. Soot, for example, is composed of carbon nanoparticles. Nevertheless, nanoparticles from sources such as diesel soot, welding fumes and photocopier toner are already associated with ill-health. The prospect of more such particles is likely to worry many. No wonder that several people at the conference in Boston mentioned the need to address public fears over nanotechnology "aggressively".

8. One of these was Clayton Teague, the director of America's National Nanotechnology Co-ordination Office. He says the American government is as sensitive to any indication of true health risk as any member of the public. Several large and well-funded studies on the environmental and health risks of nanotechnology are now under way.
9. Dr Teague adds that any decisions about nanotechnology will be made carefully and based on solid scientific data. But even if science gives the go-ahead, another one of Dr Matsuura's lessons is that this might not necessarily win the day, and that fear over potential abuses and accidents may dominate the debate.
10. One piece of advice Dr Matsuura gives is that everyone involved should have a consistent message. If investors are told a technology will change the world, someone who is concerned about the risks cannot then be told that the same technology is no big deal. It strikes a false note to say that something can be both revolutionary and nothing to worry about, he says. Such inconsistencies will breed public mistrust and fear.

#### Product placement

11. Donald Reed is a senior consultant with Ecos, a business-advisory firm based in Sydney, Australia, that acts as an intermediary between corporations and activists. Mr Reed goes as far as to recommend that companies think about the early products they choose to pursue - in particular, whether they can demonstrate the "societal value" of these products. For example, it might be worth emphasising that one of the early products of nanotechnology could be cheap and efficient photovoltaic materials, which are used to generate electricity from sunlight.

#### Questions 28-31

Look at the following people and the list of statements below. Match each person with the correct statement.

28. Clayton Teague
29. Ken Donaldson
30. Donald Reed
31. Jeffrey Malsuura

#### List of Statements

- A. Nanotechnology is being affected by factors that created opposition to biotechnology.
- B. Europeans have the most to gain from nanotechnology development.
- C. Sound scientific data will be the basis of any decisions about nanotechnology.
- D. Governments cannot shape the development of nanotechnology.
- E. Nanotechnology is not a cause for concern.
- F. Carbon nanoparticles can be breathed in and then move to the brain and blood.
- G. Companies should show how their early nanotechnology products can benefit society.

#### Questions 32-35 Complete the sentences.

Choose NO MORE THAN THREE WORDS from the passage for each answer.

32. Strong public disapproval of.....came as a shock to those working in the area.
33. Europeans reacted to the suggestion of cheaper food with.....
34. Anxiety about 'nanobots' that would in time change the planet is .....
35. Nanoparticles from photocopier toner are already linked to.....

#### Questions 36-40

Complete the summary using the list of words A-L below.

Some people believe that nanotechnology could face a 36.....fate to biotechnology. Rather than welcoming the 37....., the media and much of the general public focused their attention on the 38.....of biotechnology. So it is important to emphasize the immediate 39.....of nanotechnology; otherwise, the public could adopt a negative 40.....towards nanotech. It is therefore important for everyone involved to be consistent.

- |            |              |            |              |          |
|------------|--------------|------------|--------------|----------|
| A worse    | B greater    | C devices  | D particles  | E costs  |
| F latter   | G dangers    | H thoughts | I advantages | J former |
| K attitude | L comparable |            |              |          |

**Oxford Reading 1**  
**READING PASSAGE 1**

**RELIGIOUS DENTISTRY**

Bali is, without doubt, one of the most culturally rich islands in the world. In fact, its carved temples, dances and immaculately manicured rice terraces do all seem too perfect to be true, even down to the people's smiles. But take a closer look at those smiles and the perfect teeth do seem a bit too perfect, and for good reason. Those flattened teeth are the result of an important piece of dentistry that every young Balinese man or woman experiences in their life, known as potong gigi, or tooth filing.

Tooth filing is part of Bali's religious traditions and is not performed for cosmetic reasons. In fact, so important is the tooth filing ceremony that without it, the Balinese believe they may experience serious social or behavioural problems later in life, or their personality may change altogether.

Balinese religious life is surrounded by a belief in a variety of deities - gods and demons that inhabit different levels of the cosmic and real worlds. These deities range from the most holy in the mountains to the lowest that inhabit the ground and the sea. There are gods and goddesses in every walk of life which have special forces of their own. They inhabit temple statues, trees, even fly through the air. They exist together in a dual concept of good and evil, clean and dirty, etc. As such, both the good and the evil spirits must be appeased, and offerings are thus made at the myriad temples on the island.

It is not only the good spirits that are worshipped, for Bali has a dark and evil side too. Terrifying demons and monsters walk the earth and although they are seldom seen, they too must be appeased. These demons can take over and inhabit the body of an animal or human and wreak havoc in the community, so it is very important to strike a balance between offerings made to all spirits that swarm the island. At every stage in a person's life, he or she is susceptible to influences of the supernatural — from demons and layak, to good spirits which may bring luck. Purification of the body and mind is therefore central to Balinese religious life and the tooth-filing ceremony represents one such rite of passage from childhood to becoming an adult.

According to the Balinese, long pointed teeth resemble the fangs of animals and these give the person characteristics of the animal sides of human nature and ferocity. The Balinese believe there are six of these evil qualities: desire, greed, anger, intoxication, irresoluteness and jealousy. These are liable to flare up, along with animal instincts, when the canines are still sharp. To prevent this, if the points of the canines are filed down, together with any prominent points of the lower teeth in a special potong gigi ceremony. Although this may prevent the person taking on animal instincts and beautify the smile, it is, unfortunately offset by early tooth decay since the protective enamel is removed from the points of the teeth, exposing them to acid decay. The situation is exacerbated in those who go on to chew betel nuts, since the caustic lime rapidly attacks the teeth.

The potong gigi ceremony usually is undertaken for members of the same family together since it is a very expensive occasion to host. It is often necessary to wait until the youngest child is of age. Girls are ready for tooth filing only when they have reached sexual maturity and boys are usually older, about 17 or at least after puberty. A person must have their teeth filed before marriage and since marriage is early, the ceremony is often undertaken as a prenuptial event.

The high priest is consulted first to choose an auspicious day from the Balinese calendar. Every day has a different function - a best day for rice planting, best day for cremations and other festivals, as well as tooth-filing days. The dentist's chair, so to speak, is specially constructed for the ceremony from bamboo in the form of a rack covered with coconut leaves, blankets and a variety of offerings and frangipani flowers. Surrounding the platform is food for the guests and a huge display of skewered suckling pig, fruit, and whole roasted chickens adorn the entrance to the ceremony room.

**Questions 1-6**

Choose the appropriate letters A—D and write them in boxes 1-6 on your answer sheet.

1. The Balinese have their teeth filed
  - A. to have a perfect smile
  - B. for cosmetic reasons
  - C. to avoid problems in life
  - D. to change their personality
2. Balinese spirits
  - A. are usually easily seen
  - B. are only found in the mountains
  - C. can all fly through the air
  - D. can be found anywhere
3. Layak are probably
  - A. good spirits
  - B. evil spirits
  - C. tooth-filing experts
  - D. people whose teeth have been filed
4. When do many Balinese have their teeth filed? —
  - A. just before getting married
  - B. as part of the marriage ceremony
  - C. in early childhood
  - D. when the high priest has time
5. Where does tooth filing take place?
  - A. in the dentist's surgery
  - B. at the village temple
  - C. on a special platform
  - D. in the family residence
6. What is the most likely source of this passage?
  - A. an undergraduate essay
  - B. a scientific journal
  - C. a current affairs news magazine
  - D. an airline magazine

**Questions 7-13**

Do the following statements agree with the views of the writer in Reading Passage

YES – if the statement agrees with the writer

NO – if the statement contradicts the writer

NOT GIVEN - if it is impossible to say what the writer thinks about this.

7. Most Balinese are nervous about having their teeth filed.
8. Only the canine teeth are filed down.
9. Tooth decay soon occurs in the filed teeth.
10. Balinese religious tradition is rich and varied.
11. The tooth filing is done by the high priest.
12. There is a feast after the filing has been done.
13. Balinese custom does not permit the filing to be done for more than one person at a time.

**READING PASSAGE 2****Questions 14-18**

Reading Passage 2 has 6 sections A—F. Choose the most suitable heading for each section from the list of headings below. Write the appropriate numbers (i-ix) in boxes 14-18 on your answer sheet. Note: There are more headings than sections so you will not use all of them. You may use any of the headings more than once.



Example      EAnswer      ix**HEADINGS**

- i. Increasing popularity of pets in Australia
- ii. Dogs in cities
- iii. Benefits of pet ownership
- iv. Pet ownership in Australia
- v. Private open space and landscaping
- vi. Criticisms of pet ownership in Australian cities
- vii. Keeping pets under control
- viii. Pet owners' obligations
- ix. Housing and precinct design
- x. Pet research

- 14. Section A
- 15. Section B
- 16. Section C
- 17. Section D
- 18. Section F

**DOMESTIC PETS IN NEW URBAN AREAS***The role of urban design in successful pet ownership*

*This paper summarises the findings of an investigation into the role of urban design in successful pet ownership. There are several reasons why planners should consider pets in decisions about residential and open space development.*

- A. People are not generally aware of the popularity of pet ownership in Australia. The Morgan Research surveys estimate that in 1992, 37% of Australian households owned one or more dogs, and 30% owned one or more cats. Fifty-three per cent of all households owned either a dog or a cat. Pet-owning households are clearly a substantial group within the community.
- B. Research shows that pets play an important role in teaching children about sharing, caring, communication and responsibility. They also act as companions and protectors, stress relievers and in some cases help to foster family cohesion. While pets are traditionally associated with family-type households, they are just as important to households without children; indeed they are often surrogates for children in childless families. This applies particularly to the elderly, who usually form very close associations with their pets. In an era when the population is ageing and more people are living alone, pets can provide valuable relief from loneliness.
- C. Urban pet management has been the subject of extensive debate among veterinarians and those involved in local government for some time. Part of the reason is that people complain more readily about other people's pets than ever before. Emphasis on urban consolidation has meant that smaller homes and back gardens and multi-dwelling developments not only discourage people from owning pets but also place greater demands on scarce public open space. Pet owners may face tougher restrictions from either their local council or resident management committee.
- D. The term socially responsible pet ownership has emerged to describe a set of responsibilities to which pet owners are now expected to adhere. In meeting their responsibilities pet owners need to consider:
  - Providing an enriching environment to reduce unwanted behaviour; e.g. excessive barking.
  - Confining dogs to their premises. The advantages of this include protection from catching disease, being run over and fighting. Ideally cats should be confined to the house at night for their own protection where practicable.
  - Training pets to alter unacceptable behaviour.
  - Exercising dogs, especially if they spend long periods on their own.
- E. It might be tempting to prescribe different pets for different types of housing. Some people already have firm views about pets and housing type, mostly in relation to dogs, e.g. that the only environment for a dog is in conventional detached housing or that a "big" dog is only suitable in the country. However, suitability is as much dependent on the quality of space as it is on the quantity.

A dwelling that overlooks areas of activity is ideal for pets because it increases the amount of stimulation that can be received from the property, e.g. dwellings that overlook a park or are adjacent to a busy street. This is one way to alleviate boredom and the negative behaviours that sometimes result.

Preferably a dog should have access to some outdoor space. Open space is not essential for a cat provided an enriching environment is maintained indoors, e. g. a bay window or internal fernery. Ideally dogs should have access to all areas of open space on a property. On the whole a dog's behaviour is likely to be better if he or she can see the street. Although the dog may bark at passers-by in the street, there will be less likelihood of excessive barking that might arise through boredom. Providing a dog with surveillance of the street also enhances public security - a very positive benefit.

- F. With adequate fencing, a dog will be confined to the property. Cats are less easily constrained and are discussed below. The standard paling fence will restrain almost all dogs. They are recommended for side and rear boundaries. Solid front fences limit the view of the outside world and are not recommended. The dog will tend to be less roused by sound stimuli if he or she can see passers-by or activities in the street. However, it is important to ensure that the dog cannot get through the fence. Furthermore, all gates should be fitted with a return spring self-closing device.

Cats are not as easily restrained as dogs as they are more agile and have quite different notions of territoriality. Mostly this does not create a problem, although difficulties may arise in environmentally sensitive areas where cats may prey on wildlife. It is recommended that cats be confined to the house at night for their own protection.

The pleasures and benefits of pet ownership should be available to everyone. However, owning a pet brings with it responsibilities to which we are increasingly being called to adhere. It is hoped that the guidelines will encourage people to think about pets in decisions about residential and community development. If they do, pet ownership will not be prejudiced by the push or urban consolidation.

#### Questions 19-24

Do the following statements reflect the claims of the writer of Reading Passage 2? Write:

- |           |  |
|-----------|--|
| YES       | if the statement agrees with the writer              |
| NO        | if the statement contradicts the writer              |
| NOT GIVEN | if there is no information about this in the passage |

19. Research shows that more than half of Australian families have both a cat and a dog.
20. Many pets get lonely when their owners are away from home.
21. Although having outdoor space available is good for cats and dogs, it is not absolutely essential.
22. While fences are good for keeping animals off the streets, they should not block the animal's view of street activities.
23. Dogs should be encouraged to bark at everybody going by.
24. It is safer for cats if they are kept in the house at night.

#### Question 25

Which of the following statements A-D best reflects the views of the writer of Passage 2

- A. Although many people keep dogs in the cities, this is not truly a suitable environment for them.
- B. Although the city is less satisfactory than the country for keeping pets, it is still recommended that families with children and older people have a pet of some kind.
- C. Keeping pets in cities is appropriate so long as the owners ensure they do not annoy others.
- D. Having a pet in the city can be a rewarding experience for all concerned provided sensible precautions are taken to ensure the pet has a satisfactory environment.

PASSAGE 3**Australian Mining Companies In The Asia-Pacific Region**  
**Environmental impact on people**

Mining operations by their very nature have major impacts, positive and negative, on the local area and on local communities. They are usually in remote places and the people affected are often isolated or neglected communities.

It is inevitable that mining operations will disturb the environment in a fairly dramatic way. Forest cover may have to be cut down to clear the site of the mine or for access roads. Tunnels or open-cut pits are dug. Overburden (worthless rock or soil covering valuable ore) is removed and dumped nearby, usually to erode slowly into nearby streams and rivers. Tailings (waste rock or ore from a mining operation) from the ore processing plant have to be put somewhere - preferably into an on-site tailings dam, but more likely straight into a river and/or the sea.

Mine tailings may contain some dangerous chemicals, but the major problem is usually the huge amounts of solid sediment that they put into the river system, and the effect this has on water quality like that and marine life. This can directly affect the livelihood of people living downstream who depend on the river for fish, for drinking water for themselves and their animals or for cooking or washing. Heavy sedimentation can silt up rivers, making transportation difficult and causing fields and forests by the river banks to flood.

Other environmental effects can include air pollution from trucks tearing along dusty access roads, or more seriously, fumes from ore processing plants. Kelera, a woman who lives with her husband and two school-age children near the Australian-owned Emperor Gold Mine in Fiji, describes it thus:

*When the gas comes, sometimes in the morning, it falls like a mist, and all the children start coughing, and we cough too. The people who get asthma, they are the ones who are really frightened to death. But what can you do? When the gas comes, you have to breathe it... You know how strong it is? I tell you. The chili and the betel leaves that we grow they just die. It's as though you took hot water and spilled it on the grass, and the next day you go and see what it looks like. It's just like that.*

**Social impact**

The social impact of a modern mining operation in a remote area can also be great. Some people may have to move off their land to make way for the mine. Many more will probably relocate themselves voluntarily, moving in from more remote areas to the mining road or the mining settlement, drawn by the prospects of jobs and money, trade stores and health clinics, or just by the general excitement of the place. In many cases, the men will come in by themselves, leaving the women to fend for themselves back in the Village. Traditional agriculture and other pursuits are as a result often neglected.

But the social environment into which they come is a culturally alien one which can undermine traditional kin and gender relations and traditional authority and control, often with bitter consequences.

Large amounts of cash will normally be injected into the local community in the form of royalties or compensation to landowners, wages to mine workers or payments to sub-contractors. While this can be very beneficial it can also lead to inequalities, disputes and problems.

Those in the local community who acquire cash from wages or compensation and the power that goes with it are not necessarily those who by tradition hold power in that society. The very advent of cash can have a disruptive effect on traditional social structures.

Also in societies where resources including cash are owned communally and shared out according to traditional rules and precedents, the injection of very large amounts of money can strain the rules and tempt some to keep more than their entitlement, thus causing internal rifts, disputes and fighting.

Disputes between landowners and mining companies over payments or compensation are also common, and can lead to violent reactions against landowners by the police or armed forces, or repression by the authorities.

**For and against**

Mining also, of course, brings considerable benefits. Locally it provides Jobs and incomes, and for those who use their income wisely, an escape from grinding poverty and a life of hardship and struggle. It also brings development services such as roads, wharfs, airstrips, stores, health clinics and schools, to areas which are usually remote and often neglected by government. The advent of health care and educational facilities to remote areas that would otherwise not have them can be especially beneficial.

Opinions about a mine will usually vary. Those most in favour tend to be those living near the mine and enjoying its facilities, who have been generously compensated for loss of land or damaged environment or who are earning good money as mine workers or sub-contractors. Among those least in favour will be women living in or near the mining settlements who have to put up with alcoholism, domestic violence, sexual harassment or other social ills, and people living downstream, far enough away from the mine to be receiving little or no compensation but who nevertheless suffer its polluting effects.

**Questions 26-31**

Using NO MORE THAN THREE WORDS, answer the following questions which are based on the first part of Reading Passage 3, 'Environmental impact on people'.

- 26. In what kind of areas do mining operations usually occur?
- 27. What will be cleared from a site before mining begins?
- 28. Where do the tailings come from?
- 29. What aspect of mining will have the major impact on the river system?
- 30. What two air pollutants are often associated with a mining operation?
- 31. What does the overburden consist of?

**Questions 32-39**

Complete the summary below which is based on the second part of Reading Passage 3, 'Social impact'. Choose your answers from the box below the summary. Note: There are more words than spaces so you will not use them all. You may use any of the words more than once.

**SUMMARY**

Once a mining operation begins the 32..... is likely to change considerably. Many people will leave the area, and not all will go 33..... Most outsiders who come into the area will find 34..... in a culturally alien social environment. Among local villagers there will often be changes in the traditional 35..... which may create dissension. There will also often be 36..... over land. Often the intervention of the 37..... will be necessary to settle them. All of these factors can have a disastrous 38..... on the society. However, improvements in infrastructure and in the provision of 39..... services will be beneficial for the community.

power structure	health and education	disputes	themselves	authorities
local population	voluntarily	away	impact	local people
outsiders	consideration	wharfs and airstrips	development	factors

Oxford Reading 2  
READING PASSAGE 1

Questions 1-6

Reading Passage 1 has 7 sections A—G. Choose the most suitable heading for each section from the list of headings below. Write the appropriate numbers (i-x) in boxes 1—6 on your answer sheet.

Note: There are more headings than sections so you will not use all of them. You may use any of the headings more than once.

Example     C                          Answer     iv    

**HEADINGS**

- (i) Daniel Defoe wrote Robinson Crusoe
- (ii) Australian culture and The Bulletin
- (iii) Magazines in Australia today
- (iv) Australia's first magazine
- (v) The first magazines
- (vi) Australians depend on England for news
- (vii) Historical value of magazines
- (viii) Improvements in printing technology
- (ix) Printing of photographs
- (x) Some magazines have died

Questions 1-6

- 1. Section A
- 2. Section B
- 3. Section D
- 4. Section E
- 5. Section F
- 6. Section G

## AUSTRALIAN POPULAR MAGAZINES

- A. The magazine as a product for leisure reading, enjoyment and information, or, as the Gentlemen of the day would have put it 'edification', had its origins in England during the early years of the eighteenth century where the innovator was Daniel Defoe, the writer of Robinson Crusoe. The word magazine comes from the French *magasin* which originally meant a store-house, an apt term since the first printed magazines were holdings for a miscellany of writings on various subjects. Defoe titled his magazine 'The Review', which, five years after the first issue, was followed by two other now famous magazines The Trailer and The Spectator, both publications founded by the same partner — writers Richard Steele and Joseph Addison.
- B. As for Australian popular magazines, initially, during the founding days of the colonies, readers at the time depended on the slow sailing ships from home to bring them, among the other necessary items, newspapers and journals.
- C. It was not until 1855 that Australia produced its own, and first popular magazine. This was the highly successful Melbourne Punch, which had a life span reaching into the first quarter of the twentieth Century.
- D. Popular illustrated magazines rapidly became an important and significant factor to the literate in Australia, who were forming our national image, as were the singers of ballads and strolling entertainers who were also making a major contribution. Out of this background the now famous old Bulletin emerged in 1880. From the start The Bulletin policy was to foster and encourage Australian writers and artists: it succeeded in making the names and reputations of Henry Lawson, 'Banjo' Paterson, Steele Rudd and scores of others. It created a new, unique school of black-and-white art which, for instance, gave Phil May his big chance and eventual world recognition. The influence of The Bulletin was such that this era of the legendary 'nineties' is regarded as the source of our national culture.

From this Australian pre-Federation era a number of fascinating magazines not only founded, but many were originated and owned by distinguished writers of the day. These included the writers Henry Kendall, Marcus Clarke, Rolf Boldrewood, Randolph Bedford, Edward Dyson, Norman Lindsay and C J Dennis among others.

- E. As they were developed technical advances were promptly exploited, the most sensational being the development of photo—process engraving which allowed, for the first time, the reproduction of 'half—tone' photographs. This ingenious method simply required a photograph to be re-photographed through a dotted glass screen on to a metal sheet where, after an acid bath, the tones are simulated by a pattern of minute, raised dots varying in size. When inked the metal



**READING PASSAGE 2****Questions 17-20**

Reading Passage 2 has 5 sections A-E. From the list of headings below choose the most suitable heading for sections B to E. Write the appropriate numbers (i-viii) in boxes 17-20 on your answer sheet. Note: There are more headings than sections so you will not use all of them. You may use any of the headings more than once.

HEADINGS	
i.	Cells affected by radiation
ii.	Effects of low-dose radiation
iii.	Effects on cell multiplication
iv.	Effects of radiation on cells
v.	Sources of radiation
vi.	Radiation in the food chain
vii.	Dissemination of radiation
viii.	Health effects of radiation

Example Section A	Answer v
17. Section B	
18. Section C	
19. Section D	
20. Section E	

## RADIATION AND HUMAN HEALTH

- A. Radioactivity occurs naturally. The main source comes from natural sources in space, rocks, soil, water and even the human body itself. This is called back-ground radiation and levels vary from place to place, though the average dose is fairly constant. The radiation which is of most concern is artificial radiation which results from human activities. Sources of this include the medical use of radioactive materials, fallout and contamination from nuclear bomb tests. discharges from the nuclear industry, and the storage and dumping of radioactive waste.
- B. While artificial radiation accounts for a small proportion of the total, its effects can be disproportionate. Some of the radioactive materials discharged by human activity are not found in nature, such as plutonium, while others which are found naturally may be discharged in different physical and chemical forms, allowing them to spread more readily into the environment, or perhaps accumulate in the food-chain.

For all these reasons simple comparisons of background and artificial radioactivity may not reflect the relative hazards. Equally important, it has never been shown that there is such a thing as a safe dose of radiation and so the fact that we are progressively raising global levels should be of as much concern to us as the possibility of another major nuclear disaster like Chernobyl. Every nuclear test, nuclear reactor or shipment of plutonium means an additional and unnecessary health risk.

- C. In general, the effects of radiation can be divided into those which affect the individuals exposed and those which affect their descendants. Somatic effects are those which appear in the irradiated or exposed individual. These include cancer and leukaemia. Hereditary or genetic effects are those which arise in subsequent generations.

Many of the elements which our bodies need are produced by nuclear industry as radioactive isotopes or variants. Some of these are released into the environment, for example iodine and carbon, two common elements used by our bodies. Our bodies do not know the difference between an element which is radioactive and one which is not. So, radioactive elements can be absorbed into living tissues, bones or the blood, where they continue to give off radiation. Radioactive strontium behaves like calcium-an essential ingredient in our bones — in our bodies. Strontium deposits in the bones send radioactivity into the bone marrow, where the blood cells are formed, causing leukemia.

- D. There are three principal effects which radiation can have on cells: firstly the cell may be killed; secondly the Way the Cell multiply may be affected, resulting in cancer; and thirdly damage may occur in the cells of the ovaries or testes, leading to the development of a child with an inherited abnormality.

In most cases, cell death only becomes significant when large numbers of cells are killed, and the effects of cell death therefore only become apparent at comparatively high dose levels. If a damaged cell is able to survive a radiation dose, the situation is different. In many cases the effect of a cell damage may never become apparent. A few malfunctioning cells will not significantly affect an organ where the large majority are still behaving normally.

However, if the affected cell is a germ cell within the ovaries or testes, the situation is different. Ionising radiation can damage DNA, the molecule which acts as the cell's 'instruction book'. If that germ cell later forms a child, all of the child's cells will carry the same defect. The localised chemical alteration of DNA in a single cell may be expressed as an inherited abnormality in one or many future generations.

In the same way that a somatic cell in body tissue is changed in such a way that it or its descendants escape the control processes which normally control cell replication, the group of cells formed may continue to have a selective advantage in growth oversurrounding tissue. It may ultimately increase sufficiently in size to form a detectable cancer and in some cases cause death by spreading locally or to other parts of the body.

- E. While there is now broad agreement about the effects of high-level radiation, there is controversy over the long term effect of low level doses. This is complicated by the length of time it takes for effects to show up, the fact that the populations being studied (bomb survivors, people exposed to nuclear tests or workers in the nuclear industry ) are small and exact doses are hard to calculate.

All that can be said is that predictions made about the effects of a given dose vary. A growing number scientists point to evidence that there is a disproportionately high risk from low doses of radiation. Others assume a directly proportionate link between the received dose and the risk of cancer for all levels of dose, while there are some who claim that at low doses there is a disproportionately low level of risk.

**Questions 21-26** Classify the following as linked in the passage to:

BR Background Radiation

AR Artificial Radiation

N Neither

B Both

Write the appropriate letters in boxes 21-26 on your answer sheet.

21. produced by the human body
22. involves only safe amounts of radiation
23. is used for medical purposes
24. includes plutonium
25. produces a constant level of radiation
26. can enter the food chain

**Questions 27—32**

Complete the summary of Section D of Reading Passage 2 below. Choose your answers from the box below the summary and write them in boxes 27—32 on your answer sheet. Note: There are more words/phrases than you will need to fill the gaps. You may use a word or phrase more than once if you wish.

**SUMMARY**

Radiation can affect an organism by damaging (27)..... which may then die or malfunction. If the (28)..... affected in this way is small, the effect will not be too drastic and may not be noticeable. Alternatively, the (29)..... may grow uncontrollably and form cancers, in which case the organism is likely to die.

If the DNA in a germ cell in the ovaries or testes is affected, any (30)..... originating from that (31)..... may display ..(32).., which can in turn be passed on to further offspring.

offspring	damaged cells	further offspring	individual cells
organisms	number of cells	cancers	germ cell
	DNA		abnormalities



**READING PASSAGE 3****ASIA'S ENERGY TEMPTATION**

Nuclear power supplies 5% of the world's energy from more than 400 plants. But with the exception of France and Japan, the rich world has stopped ordering new reactors. A technology that was once deemed both clean and "too cheap to metre" has proved to be neither. The industry's chief hope now rests on the poor world. Western firms with reactors to sell will be relying on Asia, where electricity demand is growing at 8% a year. New reactors are planned in China, Taiwan, Indonesia, South Korea, Pakistan and India. It is good news for the reactors' vendors; but these countries are making a mistake.

The economic arguments for building new nuclear plants are flawed. The marginal costs of generating electricity from nuclear energy may be tiny, but, as the technology now stands, huge and uncertain costs are involved in building the power stations, dealing with spent fuel, and decommissioning. Many western governments which sang nuclear's praises now admit that gas and hydropower can produce cheaper electricity.

The economics of nuclear power in the poor world could prove to be worse still. As in the rich world, fossil fuels such as gas and coal are invariably cheaper. In China the case for nuclear power may be a little stronger as domestic reserves of coal — though huge — are located far from some areas of growing electricity demand. But most developing countries, including China, are strapped for cash and need to increase electricity supply quickly to meet soaring demand. Nuclear plants fail on both counts: they are hugely capital-intensive, and can take as long as ten years to build.

Those still charmed by nuclear power nowadays make three new arguments in its favour; that it is a defence against climate change, against another OPEC—administered oil shock, and against the inevitable exhaustion of fossil fuels. None bears close examination.

At present rates of demand, the world has enough oil to last for more than 40 years, enough gas for more than 60 years and enough coal for more than 230 years. Naturally, demand will increase; but so will reserves as companies explore more widely and costs fall. Since 1970 viable reserves of oil have almost doubled while those of gas have leapt three-fold. One distant day a crunch will come, but as it approaches fossil-fuel prices will rise, making alternative forms of energy, perhaps including nuclear power, competitive. That is no reason to spend on nuclear now.

An oil shock is a more worrying prospect, despite today's low oil price and OPEC's present inability to budge it upwards. After all, the cartel still sits on 75% of the world's economically viable reserves, and the politics of the Middle East can change at a stroke. However, even if an oil shock is a real danger, building nuclear reactors is not a good way to avert it. A higher oil price would have a relatively small effect on the supply of electricity — the only sort of energy that nuclear power can now provide. Just over a tenth of the world's electricity (and 14% of Asia's) is generated from oil, and the proportion has fallen steadily since 1970.

Besides, there are superior, non-nuclear, ways to prepare for an oil shock. Governments could take advantage of today's low oil prices to build up their stocks. Especially where congestion and pollution are serious problems, they could try to restrict the growth of car use, or promote cars which guzzle less fuel. For governments keen to reduce electricity's remaining dependence on oil still further, there are usually cheaper alternatives to nuclear, such as coal or hydropower.

Climate change is a legitimate worry. Although still riddled with uncertainties, the science of climate change is becoming firmer: put too much carbon in the atmosphere and you might end up cooking the earth, with possibly catastrophic results. But here again, switching immediately to nuclear power is not the best response. Cutting the hefty subsidies that go to the world's coal producers would help tilt the world's energy balance towards natural gas, which gives off much less carbon dioxide. Developing countries subsidise electricity prices to the tune of up to \$120 billion a year, according to World Bank estimates. If prices reflected the true costs of generation, electricity demand would fall, thus cutting greenhouse emissions.

Once the tough job of cutting subsidies is over, governments might want to reduce greenhouse gases further. Again there are carbon-free energies that merit more subsidies than



**OUP Peter May Reading 1****Reading Passage 1**

Reading Passage 1 has seven paragraphs A-G. Choose the correct heading for paragraphs B-E and G from the list of headings below. Write the correct member (i-x) in boxes 1—5 on your answer sheet.

**List of Headings**

- i. The problem of dealing with emergencies in space
- ii. How space biomedicine can help patients on Earth
- iii. Why accidents are so common in outer space
- iv. What is space biomedicine?
- v. The psychological problems of astronauts
- vi. Conducting space biomedical research on Earth
- vii. The internal damage caused to the human body by space travel
- viii. How space biomedicine First began
- ix. The visible effects of space travel on the human body
- x. Why space biomedicine is now necessary

**Example Paragraph A****Answer iv**

- 1. Paragraph B
- 2. Paragraph C
- 3. Paragraph D
- 4. Paragraph E

**Example Paragraph F****Answer ii**

- 5. Paragraph G

**SPACE TRAVEL AND HEALTH**

- A. Space biomedicine is a relatively new area of research both in the USA and in Europe. Its main objectives are to study the effects of space travel on the human body, identifying the most critical medical problems and finding solutions to those problems. Space biomedicine centres are receiving increasing direct support from NASA and/or the European Space Agency (ESA).
- B. This involvement of NASA and the ESA reflects growing concern that the feasibility of travel to other planets, and beyond, is no longer limited by engineering constraints but by what the human body can actually withstand. The discovery of ice on Mars, for instance, means that there is now no necessity to design and develop a spacecraft large and powerful enough to transport the vast amounts of water needed to sustain the crew throughout journeys that may last many years. Without the necessary protection and medical treatment, however, their bodies would be devastated by the unremittingly hostile environment of space.
- C. The most obvious physical changes undergone by people in zero gravity are essentially harmless; in some cases they are even amusing. The blood and other fluids are no longer dragged down towards the feet by the gravity of Earth, so they accumulate higher up in the body, creating what is sometimes called 'fat face', together with the contrasting 'chicken legs' syndrome as the lower limbs become thinner.
- D. Much more serious are the unseen consequences after months or years in space. With no gravity, there is less need for a sturdy skeleton to support the body, with the result that the bones weaken, releasing calcium into the bloodstream. This extra calcium can overload the kidneys, leading ultimately to renal failure. Muscles too lose strength through lack of use. The heart becomes smaller, losing the power to pump oxygenated blood to all parts of the body, while the lungs lose the capacity to breathe fully. The digestive system becomes less efficient, a weakened immune system is increasingly unable to prevent diseases and the high levels of solar and cosmic radiation can cause various forms of cancer.
- E. To make matters worse, a wide range of medical difficulties can arise in the case of an accident or serious illness when the patient is millions of kilometres from Earth. There is simply not enough room available inside a space vehicle to include all the equipment from a hospital's casualty unit, some of which would not work properly in space anyway. Even basic things such as a drip

depend on gravity to function, while standard resuscitation techniques become ineffective if sufficient weight cannot be applied. The only solution seems to be to create extremely small medical tools and ‘smart’ devices that can, for example, diagnose and treat internal injuries using ultrasound. The cost of designing and producing this kind of equipment is bound to be, well, astronomical.

- F. Such considerations have led some to question the ethics of investing huge sums of money to help a handful of people who, after all, are willingly risking their own health in outer space, when so much needs to be done a lot closer to home. It is now clear, however, that every problem of space travel has a parallel problem on Earth that will benefit from the knowledge gained and the skills developed from space biomedical research. For instance, the very difficulty of treating astronauts in space has led to rapid progress in the field of telemedicine, which in turn has brought about developments that enable surgeons to communicate with patients in inaccessible parts of the world. To take another example, systems invented to sterilize waste water on board spacecraft could be used by emergency teams to filter contaminated water at the scene of natural disasters such as floods and earthquakes. In the same way, miniature monitoring equipment, developed to save weight in space capsules, will eventually become tiny monitors that patients on Earth can wear without discomfort wherever they go.
- G. Nevertheless, there is still one major obstacle to carrying out studies into the effects of space travel: how to do so without going to the enormous expense of actually working in space. To simulate conditions in zero gravity, one tried and tested method is to work under water, but the space biomedicine centres are also looking at other ideas. In one experiment, researchers study the weakening of bones that results from prolonged inactivity. This would involve volunteers staying in bed for three months, but the centre concerned is confident there should be no great difficulty in finding people willing to spend twelve weeks lying down. All in the name of science, of course.

**Questions 6 and 7**

Answer the questions below using **NO MORE THAN THREE WORDS** for each answer.

- 6. Where, apart from Earth, can space travelers find water? .....
- 7. What happens to human legs during space travel? .....

**Questions 8-12**

Do the following statements agree with the writer’s views in Reading Passage 1? Write

- YES if the statement agrees with the views of the writer
- NO if the statement does not agree with the views of the writer
- NOT GIVEN if there is no information about this in the passage

- 8. The obstacles to going far into space are now medical, not technological.
- 9. Astronauts cannot survive more than two years in space.
- 10. It is morally wrong to spend so much money on space biomedicine.
- 11. Some kinds of surgery are more successful when performed in space.
- 12. Space biomedical research can only be done in space.

**Questions 13-14**

Complete the table below. Choose **NO MORE THAN THREE WORDS** from the passage for each answer

Research area	Application in space	Application on Earth
Telemedicine	treating astronauts	13 ..... in remote areas
Sterilization	sterilizing waste water	14 .....in disaster zones
Miniaturization	saving weight	wearing small monitors comfortably

## Passage 2

**VANISHED**

*Who pulled the plug on the Mediterranean? And could it happen again?*

*By Douglas McInrris*

Cannes. Monte Carlo. St Tropez. Magic names all. And much of the enchantment comes from the deep blue water that laps their shores. But what if somebody pulled the plug? Suppose the Mediterranean Sea were to vanish, leaving behind an expanse of salt desert the size of India. Hard to imagine? It happened.

'It would have looked like Death Valley,' says Bill Ryan, from the Lamont-Doherty Earth in Observatory in New York, one of the leaders of the team that discovered the Mediterranean had once dried up, then refilled in a deluge of Biblical proportions. Between five and six million years ago, the great desiccation touched off what scientists call the Messinian Salinity Crisis - a global chemical imbalance that triggered a wrenching series of extinctions and plunged the Earth into an ice age.

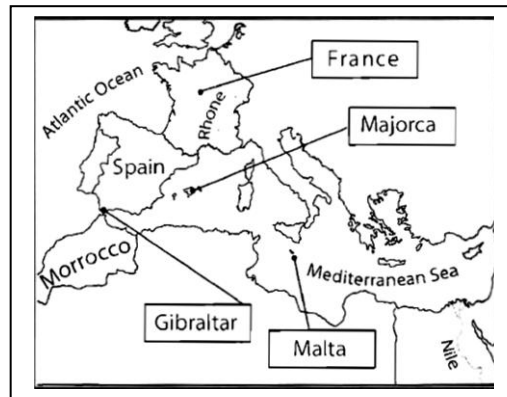

The first indications of some extraordinary past events came in the 1960s, when geologists discovered that major rivers flowing into the Mediterranean had eroded deep canyons in the rock at the bottom of the sea. River erosion of bedrock cannot occur below sea level, yet somehow the River Rhone in the South of France had managed to create a channel 1000 metres deep in the sea floor, while the Nile had cut nearly 1500 metres into the rock off the North African coast. There was more: despite the fact that the formation of caves can only take place above water, scientists so discovered a whole network beneath the island of Malta that reached an astonishing depth of 2000 metres below sea level.

Further evidence came to light in 1970, when an international team chugged across the Mediterranean in a drilling ship to study the sea floor near the Spanish island of Majorca. Strange things started turning up in core samples: layers of microscopic plants and soil sandwiched between beds of salt more than two kilometres below today's sea level. The plants had grown in sunlight. Also discovered inside the rock were fossilized shallow-water shellfish, together with salt and silt: particles of sand and mud that had once been carried by river water. Could the sea floor once have been near a shoreline?

That question led Ryan and his fellow team leader, Kenneth Hsu, to piece together a staggering chain of events. About 5.8 million years ago, they concluded, the Mediterranean was gradually cut off from the Atlantic Ocean when continental drift pinned Morocco against Spain. As the opening became both narrower and shallower, the deep outward flow from sea to ocean was progressively cutoff, leaving only the shallow inward flow of ocean water into the Mediterranean. As this water evaporated, the sea became more saline and creatures that couldn't handle the rising salt content perished. 'The sea's interior was dead as a door nail, except for bacteria,' says Ryan. When the shallow opening at Gibraltar finally closed completely, the Mediterranean, with only rivers to feed it, dried up and died.

Meanwhile, the evaporated water was falling back to Earth as rain. When the fresh water reached the oceans, it made them less saline. With less salt in it to act as an antifreeze, parts of the ocean that would not normally freeze began to turn to ice. 'The ice reflects sunlight into space,' says Ryan. 'The planet cools. You drive yourself into an ice age?'

Eventually; a small breach in the Gibraltar dam sent the process into reverse. Ocean water cut a tiny channel to the Mediterranean. As the gap enlarged, the water flowed faster and faster; until the torrent ripped through the emerging Straits of Gibraltar at more than 100 knots. 'The Gibraltar Falls were 100 times bigger than Victoria Falls and a thousand times grander than Niagara,' Hsu wrote in his book *The Mediterranean was a Desert* (Princeton University Press, 1983).

In the end the rising waters of the vast inland sea drowned the falls and warm water began to escape to the Atlantic, reheating the oceans and the planet. The salinity crisis ended about 5.4

million years ago. It had lasted roughly 400,000 years. Subsequent drilling expeditions have added a few wrinkles to Ryan and Hsu's scenario. For example, researchers have found salt deposits more than two kilometres thick — so thick, some believe, that the Mediterranean must have dried up and refilled many times. But those are just geological details. For tourists the crucial question is, could it happen again? Should Malaga start stockpiling dynamite?

Not yet, says Ryan. If continental drift does reseal the Mediterranean, it won't be for several million years. 'Some future creatures may face the issue of how to respond to nature's closure. It's not something our species has to worry about.'

**Questions 15-19** Complete the summary below. Choose NO MORE THAN THREE WORDS from the passage for each answer.

The 1960s discovery of 15 ..... in the bedrock of the Mediterranean, as well as deep caves beneath Malta, suggested something strange had happened in the region, as these features must have been formed 16 ..... sea level. Subsequent examination of the 17 ..... off Majorca provided more proof. Rock samples from 2000 metres down contained both vegetation and 18 ..... that could not have lived in deep water, as well as 19 ..... originally transported by river.

**Questions 20-22** Complete each of the following statements with the best ending from the box

20. The extra ice did not absorb the heat from the sun, so .....
21. The speed of the water from the Atlantic increased as .....
22. The Earth and its oceans became warmer when .....

- |  |
|--|
| <p>A. Africa and Europe crashed into each other.</p> <p>B. water started flowing from the Mediterranean.</p> <p>C. the sea was cut off from the ocean.</p> <p>D. all the fish and plant life in the Mediterranean died.</p> <p>E. the Earth started to become colder.</p> <p>F. the channel grew bigger, creating the waterfalls.</p> <p>G. all the ice on earth melted.</p> |
|--|

**Questions 23-27** Choose the appropriate letters A, B, C or D.

23. What, according to Ryan and Hsu, happened about 5.8 million years ago?
- A. Movement of the continents suddenly closed the Straits of Gibraltar.
- B. The water level of the Atlantic Ocean gradually fell.
- C. The flow of water into the Mediterranean was immediately cut off.
- D. Water stopped flowing from the Mediterranean to the Atlantic.
24. Why did most of the animal and plant life in the Mediterranean die?
- A. The water became too salty.
- B. There was such a lot of bacteria in the water
- C. The rivers did not provide salt water.
- D. The sea became a desert.
25. According to the text, the events at Gibraltar led to
- A. a permanent cooling of the Earth.
- B. the beginning and the end of an ice age.
- C. the formation of waterfalls elsewhere in the world.
- D. a lack of salt in the oceans that continues to this day.
26. More recent studies show that
- A. Ryan and Hsu's theory was correct in every detail.
- B. the Mediterranean was never cut off from the Atlantic.
- C. it may have been cut off more than once.
- D. it might once have been a freshwater lake.
27. At the end of the article, Ryan suggests that
- A. the Mediterranean will never dry up again.
- B. humans will have the technology to prevent it drying up again.
- C. the Mediterranean is certain to dry up again one day
- D. humans will never see the Mediterranean dry up,

## PASSAGE 3

**DOGS – A LOVE STORY**

- A. Genetic studies show that dogs evolved from wolves and remain as similar to the creatures from which they came as humans with different physical characteristics are to each Other, which is to say not much different at all. ‘Even in the most changeable mitochondrial DNA markers — DNA handed down on the mother’s side — dogs and wolves differ by not much more than one per cent,’ says Robert Wayne, a geneticist at the University of California at Los Angeles.
- B. Wolf-like species go back one to two million years, says Wayne, whose genetic work suggests dogs of some sort began breaking away about 100,000 years ago. Wolf and early human fossils have been found close together from as far back as 400,000 years ago, but dog and human fossils date back only about 14,000 years, all of which puts wolves and/or dogs in the company of man or his progenitors before the development of farming and permanent human settlements, at a time when both species survived on what they could scratch out hunting or scavenging.
- C. Why would these competitors cooperate? The answer probably lies in the similar social structure and size of wolf packs and early human clans, the compatibility of their hunting objectives and range, and the willingness of humans to accept into camp the most Suppliant wolves, the young or less threatening ones.
- D. Certain wolves or protodogs may have worked their way close to the fire ring after smelling something good to eat, then into early human gatherings by proving helpful or unthreatening. As wandering packs of twenty five or thirty wolves and clans of like numbered nomadic humans roamed the landscape in tandem, hunting big game, the animals hung around campsites scavenging leftovers, and the humans might have used the wolves’ superior scenting ability and speed to locate and track prospective kills. At night, wolves with their keen senses could warn humans of danger approaching.
- E. Times might not have been as hard back then as is commonly thought. In many instances food would have been plentiful, predators few, and the boundaries between humans and wildlife porous. Through those pores slipped smaller or less threatening wolves, which from living in packs where alpha bosses reigned would know the tricks of subservience and could adapt to humans in charge. Puppies in particular would be hard to resist, as they are today. Thus was a union born and a process of domestication began.
- F. Over the millennia, admission of certain wolves and protodogs into human camps and exclusion of larger, more threatening ones led to the development of people-friendly breeds distinguishable from wolves by size, shape, coat, ears and markings. Dogs were generally smaller than wolves, their snouts proportionally reduced. They would assist in the hunt, clean up camp by eating garbage, warn of danger, keep humans warm, and serve as food. Native Americans among others ate puppies, and in some societies it remains accepted practice.
- G. By the fourth millennium BC Egyptian rock and pottery drawings show dogs being put to work by men. Then, as now, the relationship was not without drawbacks. Feral dogs roamed city streets, stealing food from people returning from market. Despite their penchant for misbehaviour, and sometime because of it, dogs keep turning up at all the important junctures in human history.
- H. In ancient Greece, 350 years before Christ, Aristotle described three types of domesticated dogs, including speedy Laconians used by the rich to chase and kill rabbits and deer. Three hundred years later, Roman warriors trained large dogs for battle. The brutes could knock an armed man from his horse and dismember him.
- I. In seventeenth-century England, dogs still worked, pulling carts, sleds, and ploughs, herding livestock, or working as turn-spits, powering wheels that turned beef and venison over open fires. But working dogs were not much loved and were usually hanged or drowned when they got old. ‘Unnecessary’ dogs meanwhile gained status among English royalty. King James I was said to love his dogs more than his subjects. Charles II was famous for playing with his dog at Council table, and his brother James had dogs at sea in 1682 when his ship was caught in a storm. As sailors drowned, he allegedly cried out, ‘Save the dogs and Colonel Churchill?’
- J. By the late nineteenth century the passion for breeding led to the creation of private registries to protect prized bloodlines. The Kennel Club was formed in England in 1873, and eleven years later the American Kennel Club (AKC) was formed across the Atlantic. Today the AKC registers 150 breeds, the Kennel Club lists 196, and the Europe—based Fédération Cynologique Internationale

recognizes many more. Dog shows sprouted in the mid- 1800s when unnecessary dogs began vastly to outnumber working ones, as they do to this day. Unless, that is, you count companionship as a job.

**Questions 28-31**

Reading Passage 3 has ten paragraphs labeled A-I. Write the correct letters A-I in boxes 28-31 on your answer sheet.

28. Which paragraph explains how dogs became different in appearance from wolves?
29. Which paragraph describes the classification of dogs into many different types?
30. Which paragraph states the basic similarity between wolves and dogs?
31. Which paragraph gives examples of greater human concern for animals than for people?

**Questions 32-35 .**

Which FOUR of the following statements are made in the text? Choose FOUR letters from A—H and write them in boxes 32-35 on your answer sheet.

- A. In a typical camp there were many more wolves than humans.
- B. Neither the wolves nor the humans lived in one place for long.
- C. Some wolves learned to obey human leaders,
- D. Humans chose the most dangerous wolves to help them hunt.
- E. There was very little for early humans to eat.
- F. Wolves got food from early humans.
- G. Wolves started living with humans when agriculture began.
- H. Early humans especially liked very young wolves.

**Questions 36-40**

From the information in the text, indicate who used dogs in the ways listed below. Write the correct letters A—F in boxes 36—40 on your answer sheet. NB You may use any letter more than once.

Used by

- A. the Greeks
- B. the French
- C. the Egyptians
- D. the Romans
- E. the English
- F. the Native Americans

36. in war

37. as a source of energy

38. as food

39. to hunt other animals

40. to work with farm animals



OUP Peter May Reading 2  
Reading Passage 1

## Scratching the Surface

They are insidious skin parasites, infesting the occupants of factories and offices. They cause itching, prickling and crawling sensations in the skin that are almost untreatable. These creatures may only exist in the mind, but their effects are real and infectious.

The classic case occurred in a US laboratory in 1966. After new equipment was installed, workers started to suffer from itching and sensations of insects crawling over them. Complaints multiplied and the problem, attributed to 'cable mites', started to spread to relatives of the victims. A concerted effort was made to exterminate the mites using everything from DDT and mothballs to insecticide and rat poison.

Nothing worked. Thorough examination by scientific investigators could not locate any pests, or even signs of actual parasite attacks. However, they did find small particles of rockwool insulation in the air, which could cause skin irritation. A cleaning programme was introduced and staff were assured the problem had been solved. The cable mite infestation disappeared.

Another 1960s case occurred in a textile factory, where workers complained of being bitten by insects brought into the factory in imported cloth. Dermatitis swept through the workforce, but it followed a curious pattern. Instead of affecting people in one particular part of the factory, the bugs seemed to be transmitted through employees' social groups. No parasites could be found.

A third infestation spread through office staff going through dusty records that had lain untouched for decades. They attributed their skin problems to 'paper mites', but the cause was traced to irritation from paper splinters.

These are all cases of illusions of parasitosis, where something in the environment is misinterpreted as an insect or other pest. Everyone has heard of delirium tremens, when alcoholics or amphetamine users experience the feeling of insects crawling over their skin, but other factors can cause the same illusion. Static electricity, dust, fibres, and chemical solvents can all give rise to imaginary insects. The interesting thing is that they spread. The infectious nature of this illusion seems to be a type of reflex contagion. Yawn, and others start yawning. If everyone around you laughs, you laugh. Start scratching, and colleagues will scratch, too.

\* Dr Paul Marsden is managing editor of the journal of Memetics, the study of infectious ideas. He suggests that this type of group behaviour may have had a role to play in human evolution. In our distant past, one individual scratching would have alerted others that there were biting insects or parasites present. This would prime them to scratch itches of their own. Anyone who has been bitten several times by mosquitoes before they realized it will recognize the evolutionary value of this kind of advance warning. The outbreak of mass scratching may also promote mutual grooming, which is important in the necessary bonding of primate groups.

The problem comes when the reflex contagion is not related to a real threat. Normally, everyone would soon stop scratching, but people may unconsciously exaggerate symptoms to gain attention, or because it gets them a break from unappealing work. The lab workers were scanners, who spent the day laboriously examining the results of bubble-chamber tests; textile workers and clerical staff poring over records would also have found what they had to do quite tedious. Add the factor that skin conditions are notoriously susceptible to psychological influence, and it is easy to see how a group dynamic can keep the illusory parasites going.

Treatment of the condition is difficult, since few will accept that their misreading of the symptoms is the result of what psychologists call a hysterical condition. In the past, the combination of removal of irritants and expert reassurance was enough. However, these days, there is a mistrust of conventional medicine and easier access to support groups. Sufferers can reinforce each

other's illusions over the Internet, swapping tales of elusive mites that baffle science. This could give rise to an epidemic of mystery parasites, spreading from mind to mind like a kind of super virus. Only an awareness of the power of the illusion can stop it. *You can stop scratching now*

**Questions 1-5**

Classify statements 1-5 according to whether they apply to

- A. the laboratory
- B. the factory
- C. the office

1. Workers who met each other socially suffered from the condition.
2. The victims were all working with old documents.
3. They tried to kill the insects they thought were responsible.
4. They said the creatures had come in material from abroad.
5. Employees' families were affected by the condition.

**Questions 6-8**

Complete the notes below. Choose **NO MORE THAN TWO WORDS** from the passage for each answer

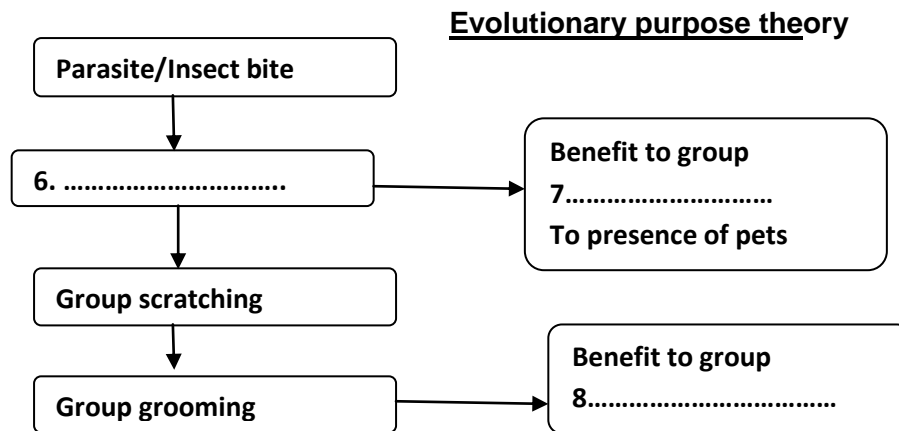

**Questions 9-13**

Do the following statements agree with the writer's views in Reading Passage 1? Write

- TRUE if the statement is true according to the passage
- FALSE if the statement is false according to the passage
- NOT GIVEN if the statement is not given in the passage

9. Some keep scratching because they know it will enable them to stop work.
10. The laboratory, factory and office employees all had boring jobs.
11. The human skin is extremely sensitive to irritants.
12. In many cases, people no longer believe what medical professionals say.
13. It is impossible to prevent the condition becoming an Internet epidemic.

**Question 14**

From the list below choose the most suitable alternative title for Reading Passage 1.

- A. The benefits of itching and scratching
- B. Increasing complaints about insects
- C. Scratching, yawning and laughing
- D. Imaginary bites and parasites
- E. Computer bites and Internet itches

**Passage 2**

Reading Passage 2 has six sections I—VI. Choose the most suitable heading for each section II—VI from the list below.

**List of headings**

- a. The lift in use
- b. The first and second lifts
- c. Restoring the lift
- d. The new canal
- e. Mechanical problems
- f. Why the lift was needed
- g. The supports of the second lift
- h. A new framework and machinery
- i. How the original lift worked
- j. A completely new lift

**Example Section I      Answer f**

- 15 Section II
- 16 Section III
- 17 Section IV
- 18 Section V
- 19 Section VI

## **THE ANDERTON BOAT LIFT**

**Section I**

When the Trent and Mersey Canal opened in 1777, the Cheshire town of Anderton was the obvious place to transfer goods to and from the nearby River Weaver. There was just one problem: the canal was fifteen metres above the river. Pathways, inclined planes, and chutes were constructed to ease the task of moving cargo by hand. Primitive railways were laid to move cargoes, cranes were built, and steam engines were later installed to power lifting. In the early 1870s, however, the Weaver Navigation Trustees decided to eliminate the cost, effort, and wastage involved in hand transportation when the engineers Edward Leader Williams and Edwin Clarke suggested a 'boat carrying lift.

**Section II**

Their design was a unique and magnificent example of the Victorians' mastery of cast iron and hydraulics. Completed in 1875, graceful in appearance, simple in use, and above all efficient, the lift was hailed as a marvel of the era, and became a prototype for larger versions on the waterways of France and Belgium.

The operating mechanism consisted of two vertical sets of interconnected hydraulic cylinders and pistons set into the bed of the river and each piston supported a boat-carrying tank 22.86 metres long and 4.72 metres wide. At rest, one tank was level with the canal and the other level with the river and to move the tanks, a small amount of water was removed from the bottom tank making it lighter than the top tank.

Because the two hydraulic cylinders were connected, the heavier top tank moved down and forced hydraulic liquid through the connecting pipe into the other cylinder pushing that piston and the lighter tank upwards. Watertight gates both on the tanks and at the entrance to the canal contained the water while the tanks were moving. A hydraulic pump driven by steam supplied the small amount of additional energy required to effect a reasonably rapid movement and to enable the tanks to be precisely levelled at the end of their journey

**Section III**

All went well for the first ten years, then pitting and grooving of the cylinders and pistons occurred. Investigations showed that the canal water used as the hydraulic liquid was contaminated by chemicals and was corrosive, therefore causing the damage.

It was immediately changed to distilled water from the steam engine powering the hydraulic pump. Corrosion was dramatically reduced but the damage had been done.

In addition, the boiler for the steam engine needed renewing, so in 1906 the Trustees ordered the construction of a new lift, to a design by their engineer J A Saner.

**Section IV**

The new lift was built over the top of the Victorian structure, utilizing the Victorian front and rear columns. The main structure had strong A-frames at either side of the new lift to support the enormous weight of the platform that now formed the top of the framework: on it was located

the new operating mechanism, which included seventy-two pulleys weighing up to 35 tonnes each.

Each of the boat-carrying tanks was now suspended on wire ropes which ran from the tank to the top of the lift, around pulleys, and down to cast-iron weights at the side of the structure. These were equal to the weight of the water-filled tank. Turning the pulleys one way or the other moved the ropes, so that one tank was raised or lowered independently of the other tank. Because the tanks were counterbalanced by the weights, only a small electrical motor was required to turn the pulleys and so move the tanks up or down.

Completed in 1908 the lift was reliable, cheap and easy to operate. Unlike the Victorian lift it was not the least bit elegant, but it was functional and it worked.

#### Section V

Both the 1875 the 1908 versions carried large volumes of commercial traffic and the principal cargoes transported were coal, china clay, salt, manufactured goods, including china ware, and agricultural produce.

Sadly trade on inland waterways in Britain declined dramatically in the 1950s, and goods traffic via the lift effectively ended in the 1960s. The 1970s increase in pleasure boating briefly prolonged its active life, but in 1982 the 'Cathedral of the Canals' was finally closed.

#### Section VI

Demolition seemed inevitable, but, after a long campaign by concerned groups, British Waterways agreed, in 1999, to save the lift. Some wanted it 'conserved as found', but that would entail replacing much of the existing structure, virtually creating a replica lift. The steel of the 1908 structure had been badly corroded by pollutants from the local chemical industries and would need replacing if it were to support the overhead machinery and 500-tonne counterweights. In addition, safety considerations would require the installation of a back-up braking system.

It was decided, therefore, to revert to the 1875 hydraulically-operated system, using the original cast-iron structure. Although the counterweights had to be removed, the 1908 framework and pulleys would be retained as a static monument. It was a huge and expensive project, and not without difficulties. Eventually in 2002, the Anderton Boat Lift was officially reopened. Boat owners and visitors alike can once again ride 'the world's first boat lift'.

#### Questions 20-24

Complete the diagram below. Choose NO MORE THAN THREE WORDS from the passage for each answer.

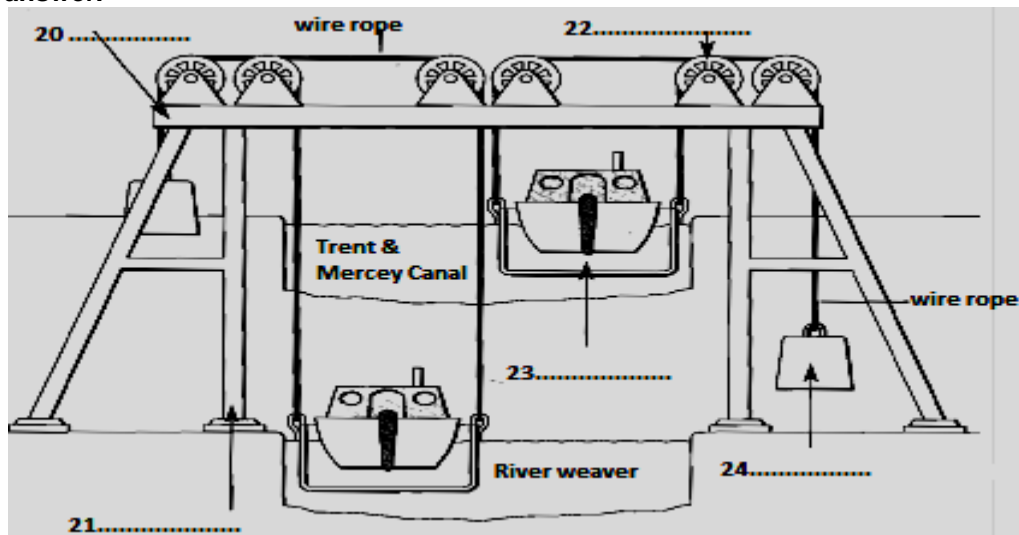

#### Questions 25—27

Complete the notes below. Choose NO MORE THAN THREE WORDS from Reading Passage 2 for each answer.

25. Similar lifts to the Anderton were later built in .....
26. Extra power to move the tanks came from .....
27. Using water from the canal harmed the .....

Passage 3**Life, but not as we know it***Henry Gee*

Astrobiology is arguably the trendiest buzzword in science after genomics. Like genomics, it is as hip as it is hard to define. Broadly speaking, it is an umbrella term for efforts of many scientists working in diverse fields to understand the conditions of life in the universe, whether on Earth or elsewhere.

The canvas is, in fact, so broad that many scientists might be astrobiologists without knowing it: astrobiology adds glamour to all science, from astronomy to zoology. Those with long memories and a cynical mien will have soon all this before. Once upon a time, there was a research programme called exobiology. Is astrobiology a new name for repackaged goods?

No, for two reasons. First, many discoveries made in the past decade have set people thinking, once again, about life elsewhere. For example, hardly a month goes by without the discovery of yet another planet orbiting a distant star. And whatever the truth about the much-disputed claims for fossils in Martian meteorites, the controversy has rehabilitated the idea of panspermia: that life can spread between planets.

Second, astrobiology is almost a trademarked term. The Nasa Astrobiology Institute is a virtual campus linking research centres with universities, all devoted to learning more about the general principles governing the origin of life in the universe. Significantly, Nature magazine recently looked at astrobiology in all its forms, from the quest to understand how life began on Earth to the prospects of finding intelligent life elsewhere in the universe.

Not that this should be a cause for wide-eyed celebration, say its critics. Ironically, the most vociferous of these come not from the world of science but from science fiction. Brian Aldiss, veteran writer, critic, and leading light of the genre, dismisses our current obsession with life elsewhere, however much it is justified by science, as an expensively scratched itch.

Aliens, he argues, are a manifestation of a fundamental human urge to populate the universe with 'others', whether gods, ghosts, little green men, or cartoon characters. Scientists should beware of taking science fiction too seriously: aliens are useful as plot devices, but this does not make them real.

A rather different criticism comes from scientists-turned-science fiction writers Jack Cohen and Ian Stewart. Both are academics - Cohen is a biologist, Stewart is a mathematician — but they have worked in SF, most recently on their novel *Wheeler's*. Their argument with astrobiology is not that aliens might not exist, but that we cannot help be constrained in our search.

All organisms on Earth, from the tiniest bacterium to the biggest whales, are constructed according to the same rules. Earthly genetic information is carried in genes made of DNA, earthly life is based on polymers of carbon, and its chemistry happens in liquid water. Because this kind of life is all we know, we tend to think that the same rules need apply everywhere. So, when probes land on Mars, or scientists look at Martian meteorites, they tend to look for the kinds of vital signs that betray earthly organisms when we have absolutely no reason for thinking that life elsewhere should be earthlike, or that our definition of life cannot be based more broadly. When the Mars Rover sat and stared at a rock, how do we know that the rock was not staring right back?

It is a fairly simple matter to come up with a definition of life that is based on what it does, rather than what it is made of. It is much more difficult, however, to make such a definition stick, preventing the term from becoming so inclusive as to be meaningless. You might start by positing three rules. The first is that life requires the existence of information that can be reproduced and inherited, with variation. Second, that living systems seem to create order and structure and maintain it in the face of chaos. Third, that a living system has to work hard to maintain its structure, and as soon as it stops doing this it degenerates.

These rules seem, at first, to be fairly precise, in as much they weed out quietly observant Martian surface rocks. But as Cohen and Stewart show in their novel, it is possible to imagine entities that follow all three rules and which appear to be alive, but which bear absolutely no resemblance to terrestrial organisms. In *Wheeler's*, they describe civilizations of floating, methane-breathing balloons in the atmosphere of Jupiter and organisms made of magnetically—confined plasma, living in the outer layers of the sun.

Other science fiction writers have imagined life on the surfaces of neutron stars, inside computers, or even in interstellar space. In his latest novel, *Look to Windward*, Lain M Banks describes organisms the size of continents, supporting entire civilizations as their intestinal parasites. All could be said to constitute life, but in Dr McCoy's immortal phrase from *Star Trek*, 'not as we know it'.

Could this mean that astrobiology, the aims of which are universal, is really no more than a parochial exercise? We might never know — perhaps even when we are visited by aliens from the other side of the galaxy who try, frantically, to gain our attention, by waving under our noses whatever it is they have under such circumstances. It will not be their fault that they will be microscopic and destroyed by a single sneeze. As Cohen and Stewart conclude in *Whealers*, 'Life goes on everywhere.'

#### Questions 28—34

Complete the summary below. Choose the answers from the box. There are more choices than spaces, so you will not need to use all of them.

The same biological and chemical principles (example) determine the make-up of all terrestrial life forms, whatever their 28 ..... . We often assume that this is the case throughout the universe, as we have 29 ..... observed other kinds of organism. Scientists therefore make the 30 ..... of searching for indications of Earth-style living things when examining material from another 31....., where the nature of any life may lie far outside their own 32 ..... definition. On the other hand, if the focus is not on 33 ..... but on behaviour, there is a risk of 34 ..... life much too broadly.

#### List of words

location	principles	previous	narrow	galaxy	frequently
discussing	rarely	defining	never	composition	size
planet	extending	mistake	breakthrough	basing	regulations

#### Questions 35-38

The text refers to the ideas of various science fiction writers. Match writers A—C with the points in 35-38. You may use any of the writers more than once.

35. Other life forms may fit a definition of life but be quite unlike anything on Earth.  
 36. People instinctively want to believe in extraterrestrial life forms.  
 37. There could be life within life on an immense scale.  
 38. Humans are inevitably limited in their ability to find life beyond Earth.

#### List of writers

- |    |                 |
|----|-----------------|
| A. | Aldiss          |
| B. | Banks           |
| C. | Cohen & Stewart |

#### Questions 39-40 Choose the appropriate letters A—D

39. The writer believes that astrobiology

- A. may now be the second most fashionable science.  
 B. is very similar to exobiology.  
 C. has proved that a meteorite from Mars contains fossils.  
 D. is not taken seriously by scientific publications.

40. Which of the following statements best describes the writer's main purpose in Reading passage 3?

- A. to describe the latest scientific developments in the study of the universe  
 B. to explain why there is growing interest in the study of astrobiology  
 C. to show that science fiction writers have nothing useful to say about aliens  
 D. to suggest that astrobiology may not help us find extraterrestrial life

**OUP Peter May Reading 3**  
**Reading Passage 1**

**Unmasking skin**

- A. If you took off your skin and laid it flat, it would cover an area of about twenty-one square feet, making it by far the body's largest organ. Draped in place over our bodies, skin forms the barrier between what's inside us and what's outside. It protects us from a multitude of external forces. It serves as an avenue to our most intimate physical and psychological selves.
- B. This impervious yet permeable barrier, less than a millimetre thick in places, is composed of three layers. The outermost layer is the bloodless epidermis. The dermis includes collagen, elastin, and nerve endings. The innermost layer, subcutaneous fat, contains tissue that acts as an energy source, cushion and insulator for the body.
- C. From these familiar characteristics of skin emerge the profound mysteries of touch, arguably our most essential source of sensory stimulation. We can live without seeing or hearing — in fact, without any of our other senses. But babies born without effective nerve connections between skin and brain can fail to thrive and may even die.
- D. Laboratory experiments decades ago, now considered unethical and inhumane, kept baby monkeys from being touched by their mothers. It made no difference that the babies could see, hear and smell their mothers; without touching, the babies became apathetic, and failed to progress.
- E. For humans, insufficient touching in early years can have lifelong results. 'In touching cultures, adult aggression is low whereas in cultures where touch is limited, adult aggression is high,' writes Tiffany Field, director of the Touch Research Institutes at the University of Miami School of Medicine. Studies of a variety of cultures show a correspondence between high rates of physical affection in childhood and low rates of adult physical violence.
- F. While the effects of touching are easy to understand, the mechanics of it are less so. 'Your skin has millions of nerve cells of various shapes at different depths,' explains Stanley Bolanowski, a neuroscientist and associate director of the Institute for Sensory research at Syracuse University 'When the nerve cells are stimulated, physical energy is transformed into energy used by the nervous system and passed from the skin to the spinal cord and brain. It's called transduction, and no one knows exactly how it takes place.' Suffice it to say that the process involves the intricate, split-second operation of a complex system of signals between neurons in the skin and brain.
- G. This is starting to sound very confusing until Bolanowski says: 'In simple terms people perceive three basic things via skin: pressure, temperature, and pain.' And then I'm sure he's wrong. 'When I get wet, my skin feels wet,' I protest. 'Close your eyes and lean back,' says Bolanowski.
- H. Something cold and wet is on my forehead — so wet, in fact, that I wait for water to start dripping down my cheeks. 'Open your eyes.' Bolanowski says, showing me that the sensation comes from a chilled, but dry, metal cylinder. The combination of pressure and cold, he explains, is what makes my skin perceive wetness. He gives me a surgical glove to put on and has me put a finger in a glass of cold water. My finger feels wet, even though I have visual proof that it's not touching water. My skin, which seemed so reliable, has been deceiving me my entire life. When I shower or wash my hands, I now realize, my skin feels pressure and temperature. It's my brain that says I feel wet.
- I. Perceptions of pressure, temperature and pain manifest themselves in many different ways. Gentle stimulation of pressure receptors can result in ticklishness; gentle stimulation of pain receptors, in itching. Both sensations arise from a neurological transmission, not from something that physically exists. Skin, I'm realizing, is under constant assault, both from within the body and from forces outside. Repairs occur with varying success.
- J. Take the spot where I nicked myself with a knife while slicing fruit. I have a crusty scab surrounded by pink tissue about a quarter inch long on my right palm. Under the scab, epidermal cells are migrating into the wound to close it up. When the process is complete, the scab will fall off to reveal new epidermis. It's only been a few days, but my little self-repair is almost complete. Likewise, we recover quickly from slight burns. If you ever happen to touch a hot burner, just put your finger in cold water. The chances are you will have no blister, little pain and no scar. Severe burns, though, are a different matter.

**Questions 1-4**

The passage has 10 paragraphs A-J. Which paragraph contains the following information?

15. the features of human skin, on and below the surface
16. an experiment in which the writer can see what is happening
17. advice on how you can avoid damage to the skin
18. cruel research methods used in the past

**Questions 5 and 6**

Choose the correct letter A, B, C or D.

19. How does a lack of affectionate touching affect children?
  - A. It makes them apathetic.
  - B. They are more likely to become violent adults.
  - C. They will be less aggressive when they grow up.
  - D. We do not really know.
20. After the 'wetness' experiments, the writer says that
  - A. his skin is not normal.
  - B. his skin was wet when it felt wet.
  - C. he knew why it felt wet when it was dry
  - D. the experiments taught him nothing new.

**Questions 7-11**

Complete each sentence with the correct ending A-J from the box below.

21. Touch is unique among the five senses
22. A substance may feel wet
23. Something may tickle
24. The skin may itch
25. A small cut heals up quickly

- A. because it is both cold and painful.
- B. because the outer layer of the skin can mend itself.
- C. because it can be extremely thin.
- D. because there is light pressure on the skin.
- E. because we do not need the others to survive.
- F. because there is a good blood supply to the skin.
- G. because of a small amount of pain.
- H. because there is a low temperature and pressure.
- I. because it is hurting a lot.
- J. because all humans are capable of experiencing it.

**Questions 12-14**

Do the following statements agree with the information given in Reading Passage 1? Write

TRUE if the statement agrees with the information

FALSE if the statement contradicts the information

NOT GIVEN if there is no information on this

26. Even scientists have difficulty understanding how our sense of touch works.
27. The skin is more sensitive to pressure than to temperature or pain.
28. The human skin is always good at repairing itself.



**Reading Passage 2****Questions 15-19**

Reading passage 2 has five sections A-E. Choose the most suitable headings for sections A—E from the list of headings below. Write the correct number i—x in boxes 15-19 on your answer sheet.

**List of headings**

- i. How to make the locks in your home more secure
- ii. How to open a lock without a key
- iii. Choosing the right tools to open locks
- iv. The cylinder and the bolt
- v. How to open a lock with a different key
- vi. Lock varieties
- vii. How a basic deadbolt system works
- viii. The people who open locks without a key
- ix. How a cylinder lock works
- x. How to pick different kinds of lock

- 15. Section A
- 16. Section B
- 17. Section C
- 18. Section D
- 19. Section E

**How Lock Picking Works****Section A**

Lock picking is an essential skill for locksmiths because it lets them get past a lock without destroying it. When you lock yourself out of your house or lose your key, a locksmith can let you back in very easily.

Lock-picking skills are not particularly common among burglars, mainly because there are so many other, simpler ways of breaking into a house (throwing a brick through a back window, for example). For the most part, only intruders who need to cover their tracks, such as spies and detectives, will bother to pick a lock.

Simply understanding the principles of lock picking may change your whole attitude toward locks and keys. Lock picking clearly demonstrates that normal locks are not infallible devices. They provide a level of security that can be breached with minimal effort. With the right tools, a determined intruder can break into almost anything.

**Section B**

Locksmiths define lock-picking as the manipulation of a lock's components to open a lock without a key. To understand lock—picking, then, you first have to know how locks and keys work.

Think about the normal deadbolt lock you might find on a front door. In this sort of lock, a movable bolt or latch is embedded in the door so it can be extended out to the side. This bolt is lined up with a notch in the frame. When you turn the lock, the bolt extends into the notch in the frame, so the door can't move. When you retract the bolt, the door moves freely. The lock's only job is to make it simple for someone with a key to move the bolt but difficult for someone without a key to move it.

**Section C**

The most widely-used lock design is the cylinder lock. In this kind, the key turns a cylinder in the middle of the lock, which turns the attached mechanism. When the cylinder is turned one way, the mechanism pulls in on the bolt and the door can open. When the cylinder turns the other way, the mechanism releases the bolt so the door cannot open.

One of the most common cylinder locks is the pin design. Its main components are the housing (the outer part of the lock which does not move), the central cylinder, and several vertical shafts that run down from the housing into the cylinder. Inside these shafts are pairs of metal pins of varying length, held in position by small springs.

Without the key, the pins are partly in the housing and partly in the cylinder, so that the mechanism cannot turn and the lock, therefore, cannot open. When you put the correct key into the cylinder, the notches in the key push each pair of pins up just enough so that the top pin is completely in the housing and the bottom pin is entirely in the cylinder. It now turns freely, and you can open the lock.

**Section D**

To pick a pin lock, you simply move each pin pair into the correct position, one by one. There are two main tools used in the picking process.

**Picks:** long, thin pieces of metal that curve up at the end (like a dentist's pick).

**A tension wrench:** the simplest sort of tension wrench is a thin screwdriver.

The first step in picking a lock is to insert the tension wrench into the keyhole and turn it in the same direction that you would turn the key. This turns the cylinder so that it is slightly offset from the housing around it, creating a slight ledge in the pin shafts.

While applying pressure on the cylinder, you slide the pick into the keyhole and begin lifting the pins. The object is to lift each pin pair up to the level at which the top pin moves completely into the housing, as if pushed by the correct key. When you do this while applying pressure with the tension wrench, you feel or hear a slight click when the pin falls into position. This is the sound of the upper pin falling into place on the ledge in the shaft. The ledge keeps the upper pin wedged in the housing, so it won't fall back down into the cylinder. In this way, you move each pin pair into the correct position until all the upper pins are pushed completely into the housing and all the lower pins rest inside the cylinder. At this point, the cylinder rotates freely and you can open the lock.

**Section E**

You'll find pin locks everywhere, from houses to padlocks. They are so popular because they are relatively inexpensive but offer moderate security. Another common type of cylinder lock is the wafer lock. These work the same basic way as pin locks, but they have flat, thin pieces of metal called wafers rather than pins. You pick the wafers exactly the same way you pick pins — in fact, it is a little bit easier to pick wafer locks because the keyhole is wider. Despite giving relatively low security, these locks are found in most cars.

Tubular locks provide superior protection to pin and wafer locks, but they are also more expensive. Instead of one row of pins, tubular locks have pins positioned all the way around the circumference of the cylinder. This makes them much harder to pick. Conventional lock-picking techniques don't usually work on this type of lock, which is why they are often found on vending machines.

**Questions 20-22**

Complete the diagram below. Choose NO MORE THAN THREE WORDS from the passage for each answer.

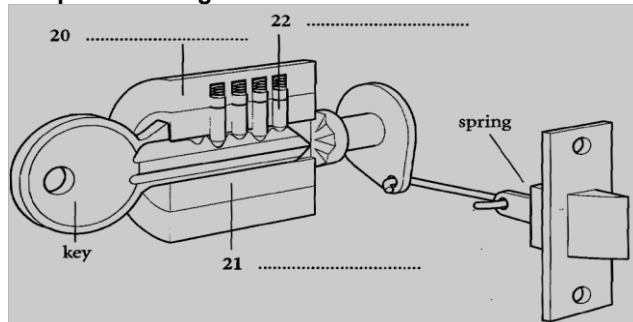

**Questions 23-25**

**Complete the notes below.**

Choose NO MORE THAN THREE WORDS from the passage for each answer.

**Picking a lock**

Turn cylinder slightly using 23 .....

Hold cylinder still and insert 24 .....

Push top pin into shaft.

Hold top pin above cylinder, on 25 .....

Lift and hold all other pins in same way.

Turn cylinder and open lock.

**Questions 26-27** Complete the table below. Choose NO MORE THAN THREE WORDS from the passage for each answer.

Type of lock	How secure	Where used
Pin	26 .....	houses, padlocks, etc
27 .....	relatively low security	most cars
Tubular	superior protection	vending machines

### Passage 3 Stars without the stripes

Managing cultural diversity is a core component of most masters programmes these days. The growth of Japanese corporations in the sixties and seventies reminded us that there were other models of business than those taught by Harvard professors and US-based management consultants. And the cultural limits to the American model have more recently been underlined by developments in Russia and central Europe over the past decade.

Yet in Britain, we are still more ready to accept the American model of management than most other European countries. As a result, UK managers often fail to understand how business practices are fundamentally different on the Continent. One outcome is that many mergers and acquisitions, strategic alliances and joint ventures between British and European companies do not achieve their objectives and end in tears.

Alternatively, managers may avoid a merger or joint venture which makes sense from a hard-nosed strategic point of view because they fear that different working practices will prevent their goals from being achieved.

Essentially, Anglo-Saxon companies are structured on the principles of project management. In the eighties, companies were downsized, with tiers of management eliminated. In the nineties, management fashion embraced the ideas of business process re-engineering, so organizations were broken down into customer-focused trading units. Sometimes these were established as subsidiary companies, at other times as profit-and-loss or cost centres.

Over the past ten years, these principles have been applied as vigorously to the UK public sector as to private-sector corporations. Hospitals, schools, universities, social services departments, as well as large areas of national government, now operate on project management principles — all with built-in operational targets, key success factors, and performance-related reward systems.

The underlying objectives for this widespread process of organizational restructuring have been to increase the transparency of operations, encourage personal accountability become more efficient at delivering service to customer, and directly relate rewards to performance.

The result is a management culture which is entrepreneurially oriented and focused almost entirely on the short term, and highly segmented organizational structures — since employee incentives and rewards are geared to the activities of their own particular unit.

This business model has also required development of new personal skills. We are now encouraged to lead, rather than to manage by setting goals and incentive systems for staff. We have to be cooperative team members rather than work on our own. We have to accept that, in flattened and decentralized organizations, there are very limited career prospects. We are to be motivated by target-related rewards rather than a longer-term commitment to our employing organization.

This is in sharp contrast to the model of management that applies elsewhere in Europe. The principles of business process re-engineering have never been fully accepted in France, Germany and the other major economies; while in some Eastern European economies, the attempt to apply them in the nineties brought the economy virtually to its knees, and created huge opportunities for corrupt middle managers and organized crime. Instead, continental European companies have stuck to the bureaucratic model which delivered economic growth for them throughout the twentieth century. European corporations continue to be structured hierarchically, with clearly defined job descriptions and explicit channels of reporting. Decision making, although incorporating consultative processes, remains essentially top-down.

Which of these two models is preferable? Certainly the downside of the Anglo-American model is now becoming evident, not least in the long-hours working culture that the application of the decentralized project management model inevitably generates.

Whether in a hospital, a software start-up or a factory the breakdown of work processes into project-driven targets leads to over-optimistic goals and underestimates of the resources needed. The result is that the success of projects often demands excessively long working hours if the targets are to be achieved.

Further, the success criteria, as calibrated in performance targets, are inevitably arbitrary and the source of ongoing dispute. Witness the objections of teachers and medics to the performance measures applied to them by successive governments. This is not surprising. In a

factory producing cars the output of individuals is directly measurable, but what criteria can be used to measure output and performance in knowledge—based activities such as R&D labs, government offices, and even the marketing departments of large corporations?

The demands and stresses of operating according to the Anglo-American model seem to be leading to increasing rates of personnel burn-out. It is not surprising that managers queue for early retirement. In a recent survey just a fifth said they would work to 65. This could be why labour market participation rates have declined so dramatically for British 50 year-olds in the past twenty years.

By contrast, the European management model allows for family-friendly employment policies and working hours directives to be implemented. It encourages staff to have a long-term psychological commitment to their employing organizations. Of course, companies operating on target-focused project management principles may be committed to family-friendly employment policies in theory. But, if the business plan has to be finished by the end of the month, the advertising campaign completed by the end of next week, and patients pushed through the system to achieve measurable targets, are we really going to let down our 'team' by clocking out at 5 p.m. and taking our full entitlement of annual leave?

Perhaps this is why we admire the French for their quality of life.

### Questions 28-31

Do the following statements agree with the writer's views in Reading Passage 3? Write

- YES if the statement agrees with the views of the writer  
 NO if the statement does not agree with the views of the writer  
 NOT GIVEN if there is no information about this in the passage

28. Attempts by British and mainland European firms to work together often fail.  
 29. Project management principles discourage consideration of long-term issues.  
 30. There are good opportunities for promotion within segmented companies.  
 31. The European model gives more freedom of action to junior managers.

### Questions 32-37

Complete the summary below. Choose the answers from the box and write the corresponding words in boxes 32-37 on your answer sheet. There are more choices than spaces, so you will not need to use all of them.

Adopting the US model in Britain has had negative effects. These include the 32..... hours spent at work, as small sections of large organizations struggle to 33 ..... unrealistic short-term objectives. Nor is there 34..... on how to calculate the productivity of professional, technical, and clerical staff, who cannot be assessed in the same way as 35..... employees. In addition, managers within this culture are finding the 36 .....of work too great, with 80% reported to be 37 ..... to carry on working until the normal retirement age.

### List of words

argument      temperature      reach      manufacturing      increasing      able  
 office      pressure      negative      predict      declining      agreement  
 discussion      no      willing      unwilling

### Questions 38-39

Complete the notes below. Choose NO MORE THAN THREE WORDS from Reading Passage 3 for each Answer.

38. Working conditions in mainland Europe are in practice more likely to be  
 39. UK managers working to tight deadlines probably give up some of their

### Question 40

Choose the correct letter A, B, C or D. Which of the following statements best describes the writer's main purpose in Reading Passage 3?

- A. to argue that Britain should have adopted the Japanese model of management many years ago  
 B. to criticize Britain's adoption of the US model, as compared to the European model.  
 C. to propose a completely new model that would be neither American nor European  
 D. to point out the negative effects of the existing model on the management of hospitals in Britain

OUP Peter May Reading 4Reading Passage 1**The power of light**

Light reveals the world to us. It sets our biological clocks. It triggers in our brains the sensations of colour. Light feeds us, supplying the energy for plants to grow. It inspires us with special effects like rainbows and sunsets. Light gives us life-changing tools, from incandescent bulbs to lasers and fibre optics.

There has been light from the beginning. There will be light, feebly, at the end. In all its forms, visible and invisible, it saturates the universe. Light is more than a little bit inscrutable. Modern physics has sliced the stuff of nature into ever smaller and more exotic constituents, but light won't reduce. Light is light- pure, but not simple. No one is quite sure how to describe it. A wave? A particle? Yes, the scientists say Both.

It is a measure of light's importance in our daily lives that we hardly pay any attention to it. Light is almost like air. It's a given. A human would no more linger over the concept of light than a fish would ponder the notion of water. There are exceptions, certain moments of sudden appreciation when a particular manifestation of light, a transitory glory; appears: a rainbow, a sunset, a flash of lightning in a dark sky the shimmering surface of the sea at twilight, the dappled light in a forest, the little red dot from a professor's laser pointer. The flicker of a candle, flooding a room with romance. The torch searching for the circuit breakers after a power cut.

Usually, though, we don't see light, we merely see with it. You can't appreciate the beauty of a rose if you ponder that the colour red is just the brain's interpretation of a specific wavelength of Light with crests that are roughly 700 nanometres apart. A theatrical lighting director told me that she's doing her job best when no one notices the lights at all. Her goal is to create an atmosphere, a mood - not to show off the fancy new filters that create colours of startling intensity.

Light is now used for everything from laser eye surgery to telephone technology. It could even become the main power source for long- distance space travel. The spaceship would have an ultrathin sail to catch the 'wind' of light beamed from an Earth-based laser. In theory such a craft could accelerate to a sizeable fraction of the speed of light, without carrying fuel.

What we call light is really the same thing in a different set of wavelengths as the radiation that we call radio waves or gamma rays or x- rays. But visible light is unlike any other fundamental element of the universe: it directly, regularly and dramatically interacts with our senses. Light offers high-resolution information across great distances. You can't hear or smell the moons of Jupiter or the Crab Nebula. So much of vital importance is communicated by visible light that almost everything from a fly to an octopus has a way to capture it - an eye, eyes, or something similar.

It's worth noting that our eyes are designed to detect the kind of light that is radiated in abundance by the particular star that gives life to our planet: the sun. Visible light is powerful stuff, moving at relatively short wavelengths, which makes it biologically convenient. To see long, stretched-out radio waves, we'd have to have huge eyes like satellite dishes. Not worth the trouble! Nor would it make sense for our eyes to detect infrared light (though some deep-sea shrimp near hot springs do see this way). We'd be constantly distracted, because in these wavelengths any heat-emitting object glows. That would include almost everything around us.

There is also darkness in the daytime: shadows. There are many kinds of shadows, more than I realized until I consulted astronomer and shadow expert David Lynch in Topanga Canyon, up the coast from Santa Monica, California. Lynch points out that a shadow is filled with light reflected from the sky, otherwise it would be completely black. Black is the way shadows on the moon looked to the Apollo astronauts, because the moon has no atmosphere and thus no sky to bounce light into the unlit crannies of the lunar surface.

Lynch is a man who, when he looks at a rainbow, spots details that elude most of us. He knows, for example, that all rainbows come in pairs, and he always looks for the second rainbow: a faint, parallel rainbow, with the colours in reverse order. The intervening region is darker. That area has a name, wouldn't you know: Alexander's dark band. As I took in the spectacular view across the canyon, Lynch explained something else: 'the reason those mountains over there look a little blue,' he said, indicating the range that obscures the Pacific, 'is because there's sky between here and those mountains. It's called airlight.'

What next for light? What new application will we see? What orthodoxy-busting cosmic information will starlight deliver to our telescopes? Will the rotating disco ball ever make a dance-floor comeback? Above all, you have to wonder: will we ever fully understand light?

There have been recent headlines about scientists finding ways to make light go faster than the speed of light. This is what science fiction writers and certain overly imaginative folks have dreamed of for decades. If you could make a spaceship that wasn't bound by Einstein's speed limit, they fantasized, you could zip around the universe far more easily.

Lijun Wang, a research scientist at Princeton, managed to create a pulse of light that went faster than the supposed speed limit. 'We created an artificial medium of cesium gas in which the speed of a pulse of light exceeds the speed of light in a vacuum,' he said, 'but this is not at odds with Einstein.' Even though light can be manipulated to go faster than light, matter can't. Information can't. There's no possibility of time travel.

I asked Wang why light goes 186,282 miles a second and not some other speed. 'That's just the way nature is,' he said. There are scientists who don't like 'why' questions like this. The speed of light is just what it is. That's their belief. Whether light would move at a different velocity in a different universe is something that is currently outside the scope of experimental science. It's even a bit 'out there' for the theorists.

What's certain is that light is going to remain extremely useful for industry, science, art, and our daily, mundane comings and goings. Light permeates our reality at every scale of existence. It's an amazing tool, a carrier of beauty; a giver of life. I can't help but say that it has a very bright future.

### Questions 1-5

Reading passage 3 describes a number of cause and effect relationships. Match each Cause (1-5) in List A, with its Effect (A-H) in List B. There are more Effects in List B than you will need, so you will not use all.

#### List A Causes

1. Much of the time, visible light is all around us.
2. Light can sometimes appear in an interesting way.
3. Visible light carries a lot of essential information.
4. Without an atmosphere, light is not reflected onto solid surfaces.
5. Only light can exceed 186,282 miles per second.

#### List B Effects

- A. Nearly all living creatures can detect it.
- B. There is a dark gap between rainbows.
- C. Light from Earth could power a spacecraft.
- D. Shadows are totally black.
- E. We cannot return to the past.
- F. We don't really notice or think about it.
- G. Certain creatures can detect infra—red light.
- H. We instantly become aware of it.

### Questions 6-10

Do the following statements agree with the views of the writer in Reading Passage 1? Write

- |           |   |
|-----------|---|
| YES       | the statement agrees with the views of the writer         |
| NO        | the statement does not agree with the views of the writer |
| NOT GIVEN | there is no information about this in the passage         |

6. It is difficult to find a single word to say exactly what light is.
7. Thinking about the physics of light can make an object seem even more beautiful.
8. Light from the sun makes it possible for life to exist on other planets.
9. It is more practical for humans to detect visible light rather than radio waves.
10. David Lynch sometimes notices things that other people don't.

### Questions 11-13

Answer the following questions using NO MORE THAN THREE WORDS for each answer.

11. What appearance can the land have when seen from a distance?
12. In what have some people imagined travelling? .....
13. In what substance did light go faster than previously thought possible?

Reading passage 2**To MBA or not to MBA**

'You could be forgiven for thinking just about every man and his dog has an MBA these days,' says Anthony Hesketh, of Lancaster University management school. We know what he means. Such is the worldwide growth and awareness of the MBA that this icon of career advancement and high salaries has almost become synonymous with postgraduate education in the business sector.

In reality, many postgraduate alternatives to an MBA exist. The total number of MBA programmes worldwide is around 2,400, while other masters and advanced courses in the whole spectrum of business education add up to more than 10,000.

Two key distinctions exist in matching what aspiring students want with what the universities offer: first is generalization versus specialization, and second is pre-experience versus post-experience and the two distinctions are interlinked. Carol Blackman, of the University of Westminster school of business, explains the first distinction. 'Specialist masters programmes are designed either for career preparation in a clearly defined type of job or profession, or are intended to develop or enhance professional competence in individuals who are already experienced. The aim is to increase the depth of their knowledge in the specialist area. The MBA, on the other hand, is a general management programme which provides practising managers with an opportunity for personal development with a broadly-based introduction to all management subject areas and the theory and practice of management'.

Specialist knowledge, however, is not everything when it comes to finding a job. Surveys by the UK's Association of Graduate Recruiters (AGR) repeatedly confirm that what employers seek, and continue to find scarce, are the personal skills that will make graduates valuable employees. In fact, when recruiting new graduates most employers considered these skills more important than specialist knowledge. What employers seek most from new graduates are enthusiasm and self-motivation, interpersonal skills, team working and good oral communication. Of the nineteen skills considered important in AGR's 2002 survey, just three require specialist education - numeracy, computer literacy and foreign languages - and these are low on the list.

Nunzio Quacquarelli, chief executive of topcareers.net, takes this further. 'Clearly, salary differentials for those with a second degree, but no significant work experience, do not match those of a good MBA and a number of years in the workplace. According to the AGR research, about 14% of employers offered a better salary to those new graduates with a masters - or even a doctorate. In my view, the salary improvement of 10% to 15% largely reflects the recruit's age and earning expectancy rather than the increase in human capital perceived by the employer. Contrast this with our latest topmba.com MBA Recruiters Survey results which shows that the average salary paid to an MBA with good work experience in the US and Europe is US\$80,000 - around two and a half times the average starting salary for a young postgraduate.'

Anthony Hesketh poses the question whether holding a second degree may even be a disadvantage. 'I have seen many reports over the years suggesting that employers view postgraduates as eminently less employable than those with a first degree. Drive, motivation and career focus, not to mention ability, are what employers value and are prepared to pay for. A postgraduate immediately has an uphill task explaining an additional year; or three years, of study.'

This view may seem cynical, but, if you are about to graduate and are considering a further degree, you should take the realities into account and ask yourself some hard questions:

- Is the qualification I am considering going to impress employers?
- Is it going to give me the edge over less qualified candidates?
- Is my consideration of a second degree because I am not sure of my career direction?
- Will employers consider that I lack drive and ambition because I have deferred my attempts to find a worthwhile job?

Many postgraduate options exist that can help you to acquire the personal skills that employers in the world of business are seeking. Consider, for example, the offerings of Strathclyde and Durham universities.

According to Dr Nic Beech, of the University of Strathclyde graduate school of business: 'The

MSc in business management (MBM), offered at USGSB is suitable for students with a good first degree - particularly a non-business first degree — but little or no business experience. Our MBM offers these graduates the opportunity to combine the specialization of their first degree with a general management qualification – something employers recognize produces a well-rounded individual.

Graduates tell us that the MBM allows them to access sectors previously out of reach. It is designed to develop the business knowledge, practical experience and personal skills which employers are seeking.'

At the University of Durham business school, Sheena Maberly is careers development officer; she too sees high value in qualifications such as the Durham MA in management (DMAM). She says: 'Whatever your first degree, from anthropology to zoology, a postgraduate business degree can help you gain a competitive edge in an over-crowded job market. If you're just starting out in your career, a business master's degree like the DMAM will enable you to develop skills directly relevant to employers' needs. So, extending your studies into management can make you better equipped to 'hit the ground running' — and that's what employers expect. Recruiters are highly selective and a vocational qualification is additional evidence of motivation.

Before committing yourself to postgraduate study, weigh up the options. Perhaps the best route might be to take a job now and plan to do an MBA a few years down the line? Try to get sponsorship from a company. Or go for a well researched and thoroughly thought through masters that will help you land a good job. Ultimately the choice is yours, but focus on the future, and on your target employer's expectations.

#### Questions 14-16

Do the following statements agree with the information given in Reading Passage 2? Write

TRUE                                    the statement agrees with the information  
FALSE                                    if the statement contradicts the information  
NOT GIVEN                            there is no information on this

14. British employers are more interested in what potential recruits can do than what they know.
15. A recruit with a specialist masters usually earns as much as an experienced employee with a good MBA.
16. The writer claims that undergraduates often plan to do a masters because they can't decide what career to follow.

#### Questions 17-21

The text quotes various individuals. Match the four people A-D with the four points made in Questions 17-21. You may use any of the people more than once.

17. Employees with postgraduate qualifications earn more because they are older and expect more.
18. It can be difficult to convince an employer that the extra time spent at university was necessary.
19. One type of course focuses on a particular aspect of business, whereas the other is more general in approach.
20. Graduates who have neither worked in nor studied business are suited to our programme.
21. There is evidence that companies may prefer to employ people without a masters degree.

#### List of people

A Anthony Hesketh  
B Carol Blackman  
C Nunzio Quacquarelli  
D Nic Beech

#### Questions 22-27

Complete the summary below Choose ONE word from Reading Passage 2 for each answer. According to Sheena Maberly, a second degree can improve the 22..... prospects of graduates in any subject. Taking a management MA gives them the 23 ..... companies are looking for, and lets them get straight on with the job as soon as they start work. It also shows they have the 24 ..... that companies seek. First, however, it is important to consider the 25 ..... : whether to start right away on a carefully chosen postgraduate course, or to do so after a few years' work, preferably with financial assistance from the 26 ..... . Whichever they decide, they should think about the 27 ..... , and what the company wants.



**Reading passage 3****Questions 28-33**

Reading passage 3 has seven paragraphs

A—G. Choose the most suitable headings for paragraphs B—G from the list of headings below.

**List of headings**

- i. Looking at a particular decade
- ii. Studying trees frozen in ice
- iii. Bringing different studies together
- iv. Records of different species compared
- v. What dendrochronology is
- vi. A war that affected the climate
- vii. Showing how trees record volcanic activity
- viii. A unique record of other times and places
- ix. Local records covering thousands of years
- x. How tree rings are formed

**Example****Paragraph A Answer v**

28. Paragraph B

29. Paragraph C

30. Paragraph D

31. Paragraph E

32. Paragraph F

33. Paragraph G

**The Ring Cycle**

- A. In the jungle of scientific debate, you cannot always see the wood for the trees. But in climate change, the wood itself sometimes holds the key. Imagine an annual register of a year's sunshine and rainfall and frost, kept up to date with perfect accuracy almost everywhere south of the tundra and north of the tropics, and available for inspection not just at any time in life but, quite often, for centuries after death. The register is, of course, the annual growth rings of trees. Match the rings from young trees with those from old forest giants and you have a centuries-long measure of the march of the seasons. Match the rings from old trees with old cathedral rafters and you have a still longer chronology — and a science called dendrochronology.
- B. Dendrochronologists, scientists who study the growth of rings in trees, have successfully constructed long tree-ring records by overlapping the patterns of wide and narrow rings in successively older timber specimens. There are now a dozen or so chronologies in the world that date back more than 5,000 years. These records, normally constructed in a restricted area, using a single species of tree, are year-by-year records of how the trees reacted to their growth conditions — an environmental history from the trees' point of view.
- C. Because tree-ring chronologies are constructed on a regional basis, there has, in the past, been a tendency for dendrochronologists to think local. However, the success of dendrochronology as an international research topic means that there are now quite a lot of chronologies available for study. As the chronologies are dated absolutely it is possible to compare the records from different areas year by year. Recently, an analysis of 383 modern chronologies, drawn from a vast area across Europe, northern Eurasia and North America was published. The authors, Keith Briffa and colleagues, observed that the maximum late-wood density of the growth rings in each year was related to the temperature in the growing season. Their analysis spanned 600 years, back to AD 1400, and presented a summer temperature record reconstructed from the huge grid of precisely dated ring densities. What they noticed was that the years of really low density — the cool summers were directly associated with large explosive eruptions, as known from historical sources and from dated layers of acid in the Greenland ice record. Greenland ice is kilometres thick and is made up of the compressed snowfall of tens of thousands of years, so the ice record can be read in almost the same way as tree-rings. I shall use this study as an example of what else tree-rings can tell us.
- D. The study provides a year-by-year estimate of temperatures, together with the dates of some major volcanoes. It is a nice clean story — volcanoes load the atmosphere with dust and aerosol and reflect back sunlight, cooling the earth's surface. This cooling leads to variations in the density of growth rings in northern conifers. Because there are a lot of other records, it is possible to test the findings from the conifer density record.
- E. We can, for example, look at what European oak was doing across the same 600-year period. Was oak responding in the same way as the conifers? The 'oak chronology' is the mean of eight regional oak chronologies across a strip of land from Ireland to Poland. It represents how, on average, hundreds of millions of oaks grew. What we see from this comparison is that the oaks clearly do respond to the volcanoes in some cases (in 1602, 1740 and 1816, for instance), but nothing like so clearly in others. Immediately it becomes apparent that the conifers tell only part of the story. There are many downturns in oak growth, and only a few are related to the conifer

record. The oaks were quite capable of being more stressed in years where the conifers were not affected. The point of this, however, is not to argue about the quality of global cooling; the point is to show what dendrochronology can do.

- F. Take the case of 1816, called the 'year without a summer' because of the terrible unseasonable cold and the crop failures that ensued. It has long been known that the primary cause of the cooling was the massive eruption of Tambora, east of Java, in 1815. However, there was a lot more going on in the run—up to 1816. Bald cypress trees in Tennessee show a major growth anomaly, with rings up to 400 per cent wider than normal, in the years following a huge earthquake in 1811-12 in Eastern America. But there is a volcanic acid layer in several Greenland and Antarctic ice cores in 1809-10, as well as in 1815-16. So here we have a combination of a highly unusual quake in an area of the USA not normally affected by earthquakes, and at least two volcanic eruptions, including Tambora, which is widely regarded as the largest in the last 10,000 years. According to Briffa, the period 1810-20 was the coldest in the last millennium, so we begin to see a combination of three unusual elements in less than ten years — exceptional earthquake, exceptional volcanic eruption, and exceptional cold. Given that the defeat of Napoleon's invasion of Russia in 1812 was famously attributed to 'General Winter', one wonders whether a natural series of events actually helped to change the course of modern history.
- G. Obviously, the case of 1816 and the years just before and after it is relatively recent and well documented. However, dendrochronology allows us to investigate the effects of such events geographically, indeed globally. We can interrogate the trees in areas where there is no historical or instrumental record. Further back in time, dendrochronology is almost the only way to reconstruct abrupt environmental events and perhaps throw new light on far darker moments in human history. Were there just political forces at work in the Dark Ages, or did violent natural events also take a hand, tipping the balance by darkening the skies and lowering the temperature? The trees were there too, and kept a record. The wood hewn from them and preserved through the centuries is slowly beginning to yield at least circumstantial evidence that could support some of the stories — think of the Arthurian wasteland, or the plagues of Egypt — so far told only in enigmatic artefacts, or in legends, epics, and religious chronicles.

**Questions 34-36** Which THREE of the following, are features of dendrochronology?

- A. It provides a complete record of the weather in any part of the world.
- B. It involves the study of ring patterns in trees of different ages.
- C. A piece of wood cut a long time ago can form part of the record.
- D. Studies show that trees of the same type all have the same number of rings.
- E. As a science it has existed for over 5,000 years.
- F. The oldest records are mostly of one type of tree in one place.

**Questions 37-40** Choose the correct letters A, B, C or D.

37. What was the result of extending the research to the European oak?
- A. It added information to that obtained from studying conifers.
  - B. It contradicted all the findings from the study of conifers.
  - C. It showed exactly the same results as those for conifers.
  - D. It proved that the world has cooled considerably since 1400 AD.
38. Which of these happened as a result of the eruption at Tambora?
- A. Agricultural production fell significantly.
  - B. There was an earthquake in North America.
  - C. Part of the polar ice caps melted.
  - D. The outcome of a war changed.
39. By studying tree rings, we may discover
- A. Whole new areas of human history.
  - B. Proof of events said to have happened.
  - C. How earlier civilizations treated the environment.
  - D. The truth about the nature of religious belief.
40. A suitable title for this passage would be
- A. How volcanoes and earthquakes changed history
  - B. The influence of trees on the world's climate
  - C. The role of trees in human history
  - D. How trees can tell us more about the past

**The world is our oyster ANSWERS**

1. C
2. B
3. D
4. A
5. N
6. NG
7. Y
8. NG
9. ECONOMY
10. PRECAUTIONS
11. MARINE PARADISE
12. S.B.
13. 224
14. PRIVATE SPONSORSHIP
15. 1938
16. 20,351
17. SURVEILLANCE
18. C
19. A
20. A
21. E
22. B
23. G
24. F
25. E
26. C
27. C
28. B
29. A
30. D
31. 75 METRES
32. CALM CENTRE
33. DESCENDING AIR
34. CONDENSATION FUNNEL
35. 20 KMS
36. 88%
37. 11%
38. OVER AN HOUR
39. 25%
40. TRI-STATE TORNADO

**Dyslexia answers**

1. FALSE
2. TRUE
3. FALSE
4. NOT GIVEN
5. TRUE
6. FALSE
7. B
8. C
9. D
10. B
11. D
12. MICROSCOPIC FLAWS
13. LATERAL GENICULATE NUCLEUS
14. A DISEASE
15. B
16. E
17. D
18. C
19. A
20. A
21. F
22. NG
23. NG
24. Y
25. N
26. Y
27. II
28. VIII
29. IV
30. X
31. I
32. VII
33. V
34. IX
35. B
36. D
37. C
38. BY ACCIDENT
39. POLLUTION
40. FORMED AN ALLIANCE

**FINDING THE LOST FREEDOM ANSWERS**

1. F
2. F
3. T
4. NI
5. F
6. B
7. B
8. B//A
9. G
10. VII
11. III
12. VI
13. IX
14. II
15. G
16. H
17. I
18. E
19. A
20. C
21. C
22. D
23. B,C,E
24. NI
25. T
26. F
27. T
28. F
29. B\*
30. E\*
31. F\*
32. G\*
33. CLEANER INDUSTRIAL PRODUCTION
34. ECONOMIC PROSPERITY
35. ENVIRONMENTAL EFFECTS
36. 4
37. 7
38. 1
39. 8
40. 6

**OUP Net Answers**

(The Coral Reefs Of Agatti Island)

1. V
2. VIII
3. XI
4. II
5. IV
6. IX
7. I
8. XII
9. VII
- 10.A
- 11.C
- 12.B
- 13.D
- 14.INDUSTRY
- 15.LABOUR
- 16.SERVICE
- 17.DECENTRALISATION
- 18.ENTERTAINMENT
- 19.BEAUTIFICATION
- 20.T
- 21.F
- 22.NG
- 23.T
- 24.T
- 25.NG
- 26.F
- 27.D
- 28.I
- 29.F
- 30.G
- 31.D
- 32.C
- 33.H
- 34.FOOD POISONING
- 35.100 / ONE HUNDRED % / PER CENT
- 36.SAUSAGE (S)
- 37.COOLER ONES
- 38.UNSPICED FOODS
- 39.SALT
- 40.A

**Focusing on IELTS AC answers**

1. II
2. VI
3. IX
4. V
5. I
6. X
7. IV
8. N
9. NG
10. Y
11. Y
12. NG
13. NG
14. DEVELOPED WORLD
15. 28
16. 18-20
17. MAJORITY
18. THE AGED
19. THE POPULATION
20. ALL ADULTS
21. D
22. A
23. C
24. A
25. B
26. B
27. B
28. G
29. E
30. D
31. F
32. C
33. TRADING PEAKS // DEMAND
34. WOMEN
35. EQUAL OPPORTUNITIES LEGISLATION
36. BE ODD // LACK AMBITION // LACK COMMITMENT
37. DISABLED PEOPLE // EMPLOYEES
38. FLEXIBLE
39. WOMAN'S ISSUE
40. THE LEGAL POSITION

**BRITISH COUNCIL TAKEIELTS AC ANSWERS ( Making Time for Science )**

**SECTION 1**

1. FALSE
2. TRUE
3. NOT GIVEN
4. FALSE
5. TRUE
6. FALSE
7. TRUE
8. C
9. C
10. B
11. A
12. D
13. C

**SECTION 2**

14. C
15. A
16. B
17. B
18. C
19. A
20. C
21. B
22. A
23. BRAIN DEAD
24. SOCIOPATHIC BEHAVIOUR
25. NEOCORTEX
26. ANIMAL PROPENSITIES

**SECTION 3**

27. C
28. D
29. B
30. E
31. A
32. YES
33. NOT GIVEN
34. NOT GIVEN
35. NO
36. PRUDENT PRACTICE
37. PRIVATISATION POLICY
38. INCENTIVES
39. PERMIT
40. REGULATORY AGENCY



**Kaplan's Answers**

1. Not Given
2. Not Given
3. True
4. False
5. False
6. True
7. Not Given
8. False
9. A
10. G
11. C
12. D
13. K
14. C
15. B
16. I
17. H
18. J
19. G
20. Multiple Sclerosis
21. Relapse Form
22. 10-15%
23. Where people live
24. White/Caucasian
25. Colder
26. Twin
27. spinal chord
28. A
29. A
30. D
31. B
32. D
33. A
34. True
35. Not Given
36. False
37. True
38. False
39. Not Given
40. False

**HIGH IMPACT READING ANSWERS  
A VERY BRIEF HISTORY OF TIME**

1. C
2. G
3. E
4. F
5. B
6. H
7. D
8. A
9. HEADBOARD
10. WEIGHT
11. PENDULUM
12. BELLOWS
13. CHEAPER
14. ACCURATE
15. MOVING PARTS
16. A
17. C
18. MELATONIN
19. LESS SUNLIGHT
20. LIGHT THERAPY
21. VOLUNTARY SUPPORT SERVICES
22. VII
23. IV
24. IX
25. V
26. II
27. X
28. VIII
29. IX
30. IV
31. VI
32. I
33. NG
34. N
35. N
36. Y
37. N
38. FACTS
39. JOB MOBILITY
40. MORE DISCRETION

**Official Materials New Answers**

**The seaweeds of New Zealand**

1. II
2. VIII
3. V
4. I
5. III
6. IX
7. NEW ZEALAND CARRAGEEN(S)
8. AGAR
9. SEA MEAL
10. COUGH MIXTURES
11. B
12. C
13. A
14. CROCHET HOOK
15. PAIRED LEAFLETS / LEAVES
16. THORN
17. (TAPERED) STEPS
18. T
19. T
20. F
21. T
22. NG
23. F
24. C\*
25. D\*
26. F\*
27. A
28. D
29. C
30. B
31. C
32. B
33. D
34. B
35. A
36. C
37. H
38. L
39. A
40. I

**COLLIN'S ANSWERS ( Affordable art)**

1. PICASSO / PABLO PICASSO
2. ANTHONY GROSS
3. LESSER-KNOWN ARTIST
4. 'UNCOOL' STYLE
5. OIL PAINTING
6. VII
7. III
8. VI
9. IV
- 10.T
- 11.NG
- 12.NG
- 13.F
- 14.B
- 15.A
- 16.FREED
- 17.TRAINED
- 18.REACHED
- 19.DESIGNED
- 20.ESTIMATED
- 21.STEEL
- 22.53 CM
- 23.LED LIGHTS
- 24.OXYGEN TANKS\*
- 25.ESCAPE HATCH\*
- 26.(RETRACTABLE) WHEELS / SET OF WHEELS
- 27.A
- 28.VI
- 29.III
- 30.II
- 31.I
- 32.VIII
- 33.B
- 34.C
- 35.D
- 36.ROCK CONCERTS / FOOTBALL
- 37.PRIVATE SECURITY FIRMS
- 38.NG
- 39.Y
- 40.Y

**FOCUS ACAD SKILLS READING Answers**

**BRIDGING THE DIGITAL DIVIDE**

1. COSTS
2. EPIDEMICS
3. DISTANCE LEARNING
4. (GOVERNMENT) INFORMATION
5. CONFIDENCE
6. C
7. B
8. D
9. A
- 10.D
- 11.C
- 12.B
- 13.D
- 14.A
- 15.B
- 16.A
- 17.F
- 18.G
- 19.C
- 20.A
- 21.E
- 22.C
- 23.POLLEN
- 24.CHEMICAL POLLUTION
- 25.HERBICIDE
- 26.DISEASE(S)
- 27.CASSAVA
- 28.A
- 29.T
- 30.NG
- 31.T
- 32.NG
- 33.F
- 34.C
- 35.F
- 36.A
- 37.D
- 38.WIND POWER
- 39.NATURAL GAS
- 40.ON-SITE
- 41.CONGESTED TRAFFIC
- 42.GEOGRAPHICAL CONDITIONS

**FOCUS ON IELTS – THE BIRTH OF BLUE**

1. (COLOURED) MINERALS
2. (CHEMICAL) TECHNOLOGY / SCIENCE
3. (ANCIENT) EGYPTIAN
4. TECHNOLOGICAL INNOVATIONS
5. B
6. C
7. E
8. C
9. G
10. D
11. B
12. A
13. F
14. G
15. C
16. I
17. B
18. E
19. PLANTING WEEDS
20. MEXICO
21. COMPOST
22. PESTICIDE USE / USE OF PESTICIDE
23. (TEAMS OF) OXEN
24. (AVERAGE) CALORIE INTAKE
25. SOIL (S)
26. INCOME / EARNINGS
27. COMPUTER MODELS
28. FLOODS, DROUGHTS
29. ERADICATION
30. (WINTER) FREEZING
31. T
32. T
33. NG
34. F
35. F
36. ORGANIC MATTER
37. MOSQUITO PREDATORS
38. BIRDS
39. JULY HEAT WAVE
40. PUDDLES / BREEDING AREAS

**READING FROM CAMBRIDGE VOCABULARY ANSWERS  
THE CAUSES DIAGNOSIS AND THE PREVENTION OF STRESS**

1. TRUE
2. TRUE
3. NOT GIVEN
4. FALSE
5. B
6. B
7. C
8. B
9. B
10. C
11. A
12. B
13. A
14. A
15. C
16. B
17. A
18. A
19. NOT GIVEN
20. YES
21. NO
22. NO
23. YES
24. NOT GIVEN
25. YES
26. C
27. G
28. E
29. B
30. F
31. A
32. D
33. H
34. C
35. E
36. F
37. C
38. D

Cambridge Grammar 2 ( Practical Intelligence lends a hand)

1. D
2. C
3. D
4. C
5. A
6. C
7. B
8. C
9. A
- 10.C
- 11.B
- 12.C
- 13.T
- 14.T
- 15.F
- 16.NG
- 17.T
- 18.F
- 19.D
- 20.A
- 21.ADVANTAGES / CHARACTERISTICS
- 22.SITUATION
- 23.INFORMATION
- 24.INGREDIENTS
- 25.SIMPLE
- 26.C
- 27.B
- 28.A
- 29.E
- 30.H
- 31.C
- 32.D
- 33.F
- 34.C
- 35.DISEASE
- 36.(LOCAL) MIDDLEMEN
- 37.SUSTAINABLE
- 38.PROFITS



**HELP NOW Answers****TEST 1**

1. A
2. D
3. B
4. D
5. B
6. C
7. A
8. B
9. REPTILES
10. EXPANDING
11. DIVERSITY
12. BEHAVIOUR
13. SUCCESS
14. VIII
15. I
16. X
17. VII
18. V
19. III
20. N
21. Y
22. N
23. NG
24. NG
25. NG
26. N
27. Y
28. AP
29. RH
30. PJ
31. BB
32. TB
33. SB
34. PJ
35. PL
36. F
37. T
38. T
39. T
40. NG

**HELP NOW Answers****TEST 2**

1. Y
2. N
3. Y
4. Y
5. NG
6. NG
7. Y
8. G
9. E
- 10.A
- 11.C
- 12.B\*
- 13.E\*
- 14.D\*
- 15.NG
- 16.F
- 17.T
- 18.NG
- 19.T
- 20.T
- 21.F
- 22.ACCEPTED
- 23.ORIGINATING
- 24.ICE CORES
- 25.DARKNESS
- 26.SEA
- 27.UNKNOWN
- 28.VIII
- 29.IX
- 30.VI
- 31.XI
- 32.I
- 33.III
- 34.EPICARP
- 35.MESOCARP
- 36.ENDOCARP
- 37.WET MILLED
- 38.OVERNIGHT
- 39.RAKED
- 40.THE CUSTOMER'S SPECIFICATIONS

**HELP NOW Answers****TEST 3**

1. C
2. G
3. F
4. A
5. E
6. B
7. Y
8. NG
9. NG
10. Y
11. Y
12. N
13. Y
14. N
15. N
16. N
17. Y
18. Y
19. NG
20. NG
21. Y
22. CLEAR
23. 95%
24. MOUTH LINING / SKIN
25. 10-20
26. NONE
27. D
28. V
29. VIII
30. I
31. III
32. VI
33. T
34. NG
35. F
36. T
37. NG
38. QUALITY ASSURANCE PROGRAM
39. BREEDING FEMALES
40. VENISON MARKET PROJECT

**HELP NOW Answers****TEST 4**

1. VIII
2. VI
3. XI
4. III
5. II
6. VII
7. A
8. B
9. B
10. C
11. Y
12. Y
13. NG
14. N
15. LM
16. PK
17. MB
18. MB
19. JC
20. BM
21. LM
22. D
23. C
24. F
25. A
26. E
27. B
28. NG
29. T
30. T
31. NG
32. F
33. KINETIC ENERGY
34. THE HEAD
35. SEASONAL WATER FLOW
36. RENOVATED
37. 15%
38. VOLUME OVER TIME
39. AT NIGHT
40. DECOMPOSING FLOODED VEGETATION

**HELP NOW Answers****TEST 5**

1. VII
2. I
3. V
4. IV
5. OXYGEN / AIR
6. THE FUEL LOAD
7. IN THE AFTERNOON
8. EMBERS
9. BACKFIRE(S)
10. RATIO (OF FUEL)
11. THE WIND
12. CROWN FIRES
13. UPHILL
14. LG
15. MM
16. LG
17. ME
18. GB
19. FR
20. LG
21. ME
22. NG
23. F
24. NG
25. T
26. F
27. T
28. Y
29. NG
30. Y
31. N
32. Y
33. Y
34. N
35. F
36. C
37. A
38. B
39. D
40. E

**HELP NOW Answers****TEST 6**

1. T
2. F
3. F
4. NG
5. A
6. D
7. C
8. G
9. B\*
10. D\*
11. F\*
12. SECRETION
13. BRITTLE
14. OXYGEN
15. NJ
16. LT
17. PK
18. TH
19. AK
20. JR
21. KD
22. DISPUTED
23. POOR
24. (INDUSTRIAL) TRAWLERS
25. (NATURAL OCCURING) ALGAE
26. SET QUOTAS
27. VIII
28. II
29. X
30. I
31. XI
32. VI
33. A
34. D
35. B
36. C
37. G
38. F
39. T
40. NG

**HELP NOW Answers****TEST 7**

1. B
2. C
3. A
4. C
5. B
6. D
7. B
8. A
9. F
10. T
11. NG
12. T
13. NG
14. VI
15. VIII
16. II
17. IV
18. I
19. V
20. H
21. E
22. F
23. A
24. D
25. B
26. D
27. E
28. D
29. B
30. C
31. D
32. T
33. T
34. T
35. CLAY LOAM
36. PESTS
37. A DECENT CROP / YIELDS
38. PASTE
39. HYDRAULIC PRESS FRAME
40. CENTRIFUGE

**HELP NOW Answers****TEST 8**

1. B\*
2. C\*
3. F\*
4. G\*
5. J\*
6. SOUTH AMERICAN COUNTRIES
7. URBANISATION AND CULTIVATION
8. (SPORT) HUNTING
9. FOOD AND BURROWS
10. WOOL
11. (THE) MOSQUITO POPULATION
12. GENETIC RESISTANCE
13. C
14. F
15. F
16. NG
17. NG
18. T
19. PERMAFROST – LOCKED
20. GREAT UNDERSEA RIVER
21. THE FOSSIL RECORD
22. STARTING
23. CULPRIT
24. A WHIRLPOOL
25. 1000 YEARS
26. 3 YEARS
27. V
28. VIII
29. VI
30. I
31. X
32. III
33. VII
34. NG
35. Y
36. Y
37. B
38. H
39. G
40. F



**HELP NOW Answers****TEST 9**

1. FG
2. JS
3. SL
4. JF + PF
5. CC
6. CC
7. PH
8. FG
9. F
10. T
11. F
12. NG
13. T
14. NG
15. Y
16. Y
17. NG
18. N
19. N
20. NG
21. (SUBTLE) DIFFERENCE
22. AWARE OF
23. TEMPO + PITCH
24. (PAID) VOLUNTEERS
25. A TELEPHONE CONVERSATION
26. POLITICIANS
27. VIDEOTAPE
28. VI
29. XI
30. VIII
31. V
32. X
33. II
34. VII
35. C
36. D\*
37. F\*
38. G\*
39. (A CREAMY) PULP
40. FRAMED SCREENS

**HELP NOW Answers TEST 10**

1. VI
2. XI
3. VIII
4. I
5. IX
6. III
7. V
8. MOST ABUNDANT ELEMENT
9. BILLIONS OF DOLLARS
10. ON-BOARD REFORMERS
11. THE AIRSHIP'S FABRIC
12. POWER AND ACCELERATION
13. B
14. A
15. D
16. F
17. G
18. A
19. E
20. D
21. B
22. C
23. B
24. C
25. (THE) NUCLEUS
26. THE US
27. BIOETHICS ADVISORY COMMISSION
28. A
29. B
30. D
31. E
32. C
33. F
34. G
35. T
36. T
37. T
38. NG
39. T
40. T

**IELTS MASTERCLASS COMPILED READING 1 ANSWERS**  
**THE INVISIBLE THREAD**

1. F
2. A
3. C
4. D
5. G
6. B
7. NO
8. YES
9. YES
10. NG
11. NO
12. NO
13. NG
14. IX
15. VII
16. VI
17. I
18. VIII
19. II
20. IV
21. D
22. G
23. F
24. B
25. 543 MILLION YEARS
26. TINY ULTRASONIC TRANSMITTERS
27. A BRAIN
28. B
29. A
30. C
31. A
32. A
33. B
34. B
35. LIMBS
36. CRAMP
37. MIRROR
38. INTACT
39. REFLECTION
40. RELIEVING

**IELTS MASTERCLASS COMPILED READING 2 ANSWERS****Tower of strength**

1. C
2. B
3. D
4. D
5. E
6. D
7. B
8. G
9. C
10. F
11. (BUCKMINSTER) FULLER
12. TENSION BANDS / RUBBER BANDS
13. MICROFILAMENTS
14. (PROTEINS CALLED) INTEGRINS
15. T
16. T
17. NG
18. F
19. F
20. RAIN
21. (HUGE) SAND (DUNES)
22. CLIMATE
23. AD 650
24. FORTRESSES
25. B\*
26. C\*
27. F\*
28. C
29. B
30. E
31. A
32. D
33. SICILIAN
34. GRANDFATHER
35. SEVENTY
36. OVER TWENTY COUNTRIES
37. THREE LANGUAGES
38. AN INTERVIEW
39. RUNS IN FAMILIES
40. A\*
41. E\*

**IELTS Resource Pack Reading 1 – Bumblebee Conservation**

1. VIII
2. X
3. I
4. IV
5. VII
6. VI
7. C
8. C
9. A
10. D
11. YES
12. YES
13. NG
14. III
15. II
16. VII
17. IV
18. F
19. T
20. T
21. NG
22. F
23. C
24. A
25. D
26. B
27. D
28. D
29. B
30. D
31. A
32. C
33. C
34. B
35. I
36. F
37. UTILIZATION OF RESOURCES
38. UNEMPLOYMENT
39. NEW PERSPECTIVES
40. COULD HAVE ACHIEVED ALONE

**IELTS Resource Pack Reading 2 – Royal National Lifeboat**

1. 1937
2. 1852
3. 1825
4. 1932
5. 1854
6. B
7. A
8. B
9. NG
10. N
11. NG
12. Y
13. Y
14. H
15. A
16. E
17. C
18. F
19. Y
20. Y
21. NG
22. Y
23. N
24. NG
25. N
26. NG
27. C
28. IX
29. IV
30. III
31. I
32. VII
33. A\*
34. C\*
35. E\*
36. H\*
37. B
38. D
39. H
40. C

**Cambridge Grammar Answers****JUMPING SPIDERS**

1. E
2. D
3. F
4. D
5. B
6. A
7. B
8. B
9. F
10. A
11. A
12. C
13. B

**The History of Biro**

14. VII
15. IX
16. VI
17. IV
18. VIII
19. III
20. D
21. A
22. C
23. LEATHER
24. (IN) ARGENTINA
25. (IN) 1945

**Dressed to Dazzle**

26. D
27. G
28. C
29. A
30. B
31. F
32. INGEO
33. SOYABEAN
34. WEAVING
35. ELECTRONIC COMPONENTS
36. BATTERY
37. COSTUMES
38. FRAGILE
39. ACCESSORIES
40. HANDBAGS

**404 READING ANSWERS – LIFE CYCLE OF STAR**

1. B
2. A
3. D
4. G
5. H
6. E
7. NUCLEAR FUSION
8. CORE
9. STARTS TO DIE
10. EXPLODE / COLLAPSE
11. GRAVITY / GRAVITATIONAL FIELD
12. BLACK HOLES
13. DEBRIS / MATERIALS
14. (MATURE) GREEN DEVELOPMENTS
15. UNDER / BELOW / UP TO / LESS THAN 24
16. WITHIN 24 HOURS
17. COLOUR / COLOURING (PROCESS)
18. VARIATION
19. CARBON DIOXIDE / ETHYLENE GAS
20. ETHYLENE GAS / CARBON DIOXIDE
21. FALSE
22. FALSE
23. TRUE
24. FALSE
25. NOT GIVEN
26. TRUE
27. TRUE
28. II
29. I
30. V
31. IV
32. MASS TOURISM
33. THE BENEFITS / ADVANTAGES
34. LOW KEY / SMALLER SCALE
35. UNETHICAL TOUR OPERATORS / ECOTOURISM OPERATORS
36. NATURE ITSELF / NATURE ALONE / NATURAL ATTRACTIONS
37. B
38. D
39. C
40. D



**ACHIEVE IELTS ANSWERS**

**TEST 1**

1. F
2. T
3. T
4. NG
5. NG
6. T
7. T
8. FOOD LABELS
9. VEGETABLE OILS
10. HEART DISEASE / CARDIVASCULAR DISEASE
11. DEPARTMENT OF HEALTH
12. BISCUITS AND CRISPS ( IN EITHER ORDER)
13. (THE) USA
14. D
15. F
16. B
17. A
18. E
19. C
20. MOLECULES
21. CELL WALLS / STRUCTURAL COMPONENT
22. FERMENT
23. SWITCHGRASS
24. CORN
25. ENVIRONMENTALLY
26. C
27. C
28. D
29. E
30. B
31. D
32. A
33. C
34. E
35. G
36. B
37. I
38. C
39. H
40. F

**ACHIEVE IELTS TEST 2**

1. B\*
2. F\*
3. G\*
4. C\*\*
5. E\*\*
6. F\*\*
7. F
8. R
9. G
10. H
11. O
12. M
13. C
14. IV
15. VIII
16. VI
17. X
18. IX
19. II
20. VII
21. I
22. H
23. F
24. C
25. A
26. E
27. B
28. A
29. D
30. B
31. B
32. A
33. C
34. T
35. F
36. T
37. F
38. NG
39. T
40. NG

**ACHIEVE IELTS TEST 3**

1. VI
2. II
3. IX
4. VIII
5. IV
6. V
7. F
8. L
9. D
10. C
11. I
12. G
13. C
14. G
15. B
16. F
17. D
18. A
19. G
20. E
21. N
22. N
23. NG
24. Y
25. NG
26. Y
27. E
28. I
29. K
30. J
31. B
32. F
33. D
34. H
35. GENDER BLIND
36. ECONOMIC FORCE
37. MULTIVERSITY
38. WORK/LIFE BALANCE
39. THIRD SHIFT
40. NETWORK AND RELATIONSHIPS ( IN EITHER ORDER)

**ACHIEVE IELTS TEST 4**

1. (SMALL) FLAPS
2. (THEIR/THE) SHELLS
3. (ABOUT)  $1/3$  // A THIRD
4. ROCKS (ON LAND)
5. (OVER) 100,000 YEARS
6. FISHING AND TOURISM (IN EITHER ORDER)
7. CORAL(S)
8. MICROBES
9. (THE) ATMOSPHERE
10. CLOUDS
11. COOLER
12. GLOBAL WARMING
13. C
14. C
15. D
16. C
17. B
18. A
19. B
20. STANDARDS/RULES
21. DISTRIBUTION
22. SUPPLIERS
23. PESTICIDES
24. PLANTATION OWNERS
25. PROTECTED FORESTS
26. MONITORS
27. (SENSITIVE) BALANCE
28. 5000/ FIVE THOUSAND / RPM / REVOLUTIONS PER MINUTE
29. LIQUID NITROGEN
30. GLASS TUBE
31. B
32. A
33. C
34. A
35. B
36. F
37. T
38. NG
39. T
40. F

**IELTS INTENSIVE ANSWERS      TEST**

1. A HUNDRED YEARS / 100 YEARS
2. MENTALLY CONFUSED / BEHIND MONOLINGUAL CHILDREN
3. (WELL DEVELOPED) LANGUAGE
4. II
5. VI
6. IV
7. I
8. IX
9. V
10. F
11. F
12. NG
13. T
14. B\*
15. D\*
16. G\*
17. A
18. D
19. C
20. C
21. A
22. B
23. A
24. B
25. C
26. A
27. F
28. T
29. F
30. NG
31. T
32. T
33. (THE) MEDITERRANEAN
34. GREECE
35. HIS ( COLOURFUL) LIFESTYLE
36. POLITICAL VIEWS
37. OUTPUT
38. FAILING HEALTH
39. CLIMATE
40. INDIVIDUALISM AND IMAGINATION

**IELTS INTENSIVE ANSWERS****TEST 2**

1. LOCAL CONSUMPTION
2. COMPETITION
3. BANNED
4. MEET (THE) DEMAND
5. EFFICIENT
6. STEAM (ENGINES)
7. C
8. D
9. A
10. F
11. NG
12. T
13. T
14. C\*
15. E\*
16. F\*
17. C
18. C
19. A
20. DEFINITION
21. EXCESSIVE
22. CIVIL
23. MAKE A COMPLAINT
24. WITNESSES / NEIGHBOURS AND ACQUAINTANCES
25. MAGISTRATES' COURT
26. PHYSICAL VIOLENCE
27. B
28. C
29. C
30. ANCESTORS
31. FAR-FETCHED
32. CLIMATE-WARMING
33. RECORDED HISTORY
34. ICE AGE
35. F
36. NG
37. T
38. F
39. NG
40. T

**IELTS INTENSIVE ANSWERS TEST 3**

1. (EXISTING) PHONE NETWORKS
2. PRESS A BUTTON
3. (IN) CARS
4. 2G / THE SECOND GENERATION
5. BATTERY DESIGN
6. MACHINE-GENERATED
7. WIRELESSLY
8. PAIRED SPECTRUM
9. UPLINK
10. DOWNLINK
11. B
12. D
13. A
14. F
15. NG
16. T
17. T
18. NG
19. F
20. T
21. C
22. B
23. C
24. A
25. (THE) RESPIRATORY TRACT
26. HUMAN TO HUMAN
27. C
28. B
29. B
30. C
31. A
32. (MARKET) RESEARCH
33. (LOCAL) GOVERNMENT CONTROLS
34. PRICE LIST
35. MAXIMUM NUMBER
36. LIMITED MARKET
37. A
38. B
39. C
40. D

**IELTS INTENSIVE ANSWERS****TEST 4**

1. NG
2. F
3. F
4. T
5. NG
6. C
7. A
8. B
9. D
10. A
11. G
12. C
13. H
14. E
15. PRESSURE
16. HIGH STAKES
17. LEAGUE TABLES
18. TEACHING STANDARDS
19. MORE CHILD-FRIENDLY
20. F
21. NG
22. F
23. T
24. C
25. C
26. D
27. B
28. Y
29. N
30. N
31. NG
32. N
33. B
34. C
35. D
36. A
37. B
38. D
39. A
40. F



**IELTS INTENSIVE ANSWERS****TEST 5**

1. ROLE
2. SURVIVAL
3. THE WILD
4. PROTECTION
5. GENES
6. AMERICAN FOOTBALL
7. PASSING THE BALL
8. OPINIONS
9. FILMED
10. MOVED HER FOOT
11. A
12. B
13. C
14. SMALLER HEADPHONES
15. DIGITAL MUSIC
16. THE VOLUME
17. 120 DECIBELS
18. (DECIBEL) LEVEL
19. Y
20. Y
21. NG
22. Y
23. N
24. (A) VIRTUAL (WORLD)
25. MORAL IMPLICATIONS
26. LINGUISTIC CREATIVITY
27. V
28. X
29. I
30. IV
31. VIII
32. VII
33. (HUMAN) CHARACTERISTICS
34. IDENTICAL TWINS
35. SIGNATURE
36. FALSE
37. T
38. NG
39. F
40. T

**IELTS INTENSIVE ANSWERS****TEST 6**

1. A\*
2. E\*
3. G\*
4. VIII
5. VI
6. V
7. I
8. VII
9. III
10. AMERICAN COLONIES
11. NEW SOUTH WALES
12. PRISON COLONY
13. SYDNEY COVE
14. RIPS
15. PANDANUS
16. WIDE
17. TAPERED
18. A
19. C
20. B
21. C
22. C
23. ANIMALS
24. NEW CALEDONIA
25. PHYSICAL LAWS
26. CHIMPANZEES / CHIMPS
27. D
28. C
29. N
30. NG
31. Y
32. Y
33. NG
34. NG
35. VOLCANIC ERUPTION
36. THE MEDIA
37. ENGLAND
38. (LOCAL) ECONOMY
39. ISLAND'S STAMPS
40. HURRICANE

## TESTBUILDER 2 TEST 1

1. III
2. I
3. II
4. VII
5. WORLDWIDE PHENOMENON
6. VALUABLE RESOURCE
7. AGRICULTURAL TECHNOLOGY
8. INFRASTRUCTURE FACILITIES
9. Y
10. Y
11. N.G.
12. N
13. N
14. B\*
15. E\*
16. F\*
17. ESSENTIAL ELEMENT
18. APPLICATIONS
19. PORTABLE COMMODITY
20. TAXES
21. SPIRITS
22. T
23. NG
24. F
25. F
26. T
27. T
28. I
29. D
30. G
31. C
32. E
33. A
34. D
35. B
36. C
37. A
38. E
39. C
40. A

## TESTBUILDER 2 TEST 2

1. A
2. D
3. C
4. B
5. D
6. MURLINS
7. (BASIC) GRANT
8. HYBRIDS
9. CROSS-BREEDING (STUDIES)
- 10.(IT) STIMULATES REPRODUCTION
- 11.RELATIVELY HIGH
- 12.DEVELOPMENT AND INVESTMENT
- 13.CATHOLIC FOOD TASTES
- 14.B
- 15.C
- 16.E
- 17.G
- 18.C
- 19.J
- 20.F
- 21.H
- 22.K
- 23.L
- 24.A
- 25.TRUE
- 26.F
- 27.NG
- 28.IV
- 29.I
- 30.VI
- 31.VII
- 32.IX
- 33.II
- 34.A
- 35.D
- 36.C
- 37.A\*
- 38.B\*
- 39.F\*
- 40.D

**TESTBUILDER 2 TEST 3**

1. TYPES
2. TUNNELS
3. AREAS
4. CRACKS
5. FRACTURES
6. PASSAGE
7. STREAMS
8. FLOOR
9. A
10. E
11. TRUE
12. TRUE
13. NOT GIVEN
14. C
15. B
16. C
17. D
18. C
19. THOMAS CARLYLE
20. BIRD FLIGHT
21. LOSING MONEY
22. CLOCKWISE
23. D
24. C
25. G
26. E
27. C
28. F
29. D
30. C
31. B
32. A
33. ADVICE
34. ACADEMIC INSTITUTIONS
35. LICENCE TO PRACTISE
36. LONG-TERM DECLINE
37. SELF REGULATION
38. MORE OPEN
39. DEMANDING
40. SPECIALISATION

**TESTBUILDER 2 TEST 4**

1. H
2. E
3. C
4. B
5. D
6. A
7. BLUE GLAZE
8. CHARACTERS
9. BORDER
10. 19.5 INCHES / 495 MM
11. T
12. NG
13. F
14. IX
15. II
16. VIII
17. VII
18. VI
19. XI
20. C
21. B
22. D
23. A
24. N
25. Y
26. NG
27. D
28. C
29. F
30. G
31. A
32. GENETICALLY MODIFIED ORGANISMS / GMOs
33. SCEPTICISM
34. ABSURD
35. ILL HEALTH
36. L
37. F
38. G
39. I
40. K

**Oxford Reading 1 Answers – Religious Dentistry**

1. C
2. D
3. B
4. A
5. C
6. D
7. NG
8. N
9. Y
10. Y
11. NG
12. Y
13. N
14. IV
15. III
16. VI
17. VIII
18. VII
19. N
20. NG
21. Y
22. Y
23. N
24. Y
25. D
26. REMOTE / ISOLATED PLACES
27. FOREST (COVER)
28. ORE PROCESSING PLANT
29. SOLID SEDIMENT
30. DUST / FUMES (must have both)
31. (WORTHLESS) ROCK SOIL
32. LOCAL POPULATION
33. VOLUNTARILY
34. THEMSELVES
35. POWER STRUCTURE
36. DISPUTES
37. AUTHORITIES
38. IMPACT
39. HEALTH AND EDUCATION

**Oxford Reading 2 Answers – Australia's Popular Magazines**

1. V
2. VI
3. II
4. VIII
5. III
6. VII
7. O
8. N
9. N
10. B
11. O
12. MELBOURNE PUNCH / PIX / PEOPLE
13. MELBOURNE PUNCH
14. THE BULLETIN
15. AUSTRALASIAN POST
16. PENTHOUSE / PLAYBOY / CLEO / COSMOPOLITAN
17. VII
18. VIII
19. IV
20. II
21. BR
22. N
23. AR
24. AR
25. N
26. B
27. INDIVIDUAL CELLS
28. NUMBER OF CELLS
29. DAMAGED CELLS
30. OFFSPRING
31. GERM CELL
32. ABNORMALITIES
33. G
34. C
35. D
36. E
37. TIME / MONEY / CAPITAL
38. RADIATION / NUCLEAR ACCIDENT
39. WIND / SUN / SOLAR / HYDRO
40. RENEWABLE / CARBON-FREE ENERGIES
41. WIND TURBINES / WIND MILLS
42. SAFELY AND CLEANLY



**OUP PETER MAY TEST 1 ANSWERS**

1. X
2. IX
3. VII
4. I
5. VI
6. (ON/FROM) MARS
7. THEY BECOME THINNER
8. YES
9. NG
10. NO
11. NG
12. NO
13. COMMUNICATE WITH PATIENTS
14. FILTER CONTAMINATED WATER
15. (DEEP) CANYONS
16. ABOVE
17. SEA FLOOR
18. SHELLFISH
19. SILT / SAND AND MUD
20. E
21. F
22. B
23. D
24. A
25. B
26. C
27. D
28. F
29. J
30. A
31. I
32. B\*
33. C\*
34. F\*
35. H\*
36. D
37. E
38. F
39. A
40. E

**OUP PETER MAY TEST 2 ANSWERS**

1. B
2. C
3. A
4. B
5. A
6. INDIVIDUAL SCRATCHING
7. ALERTED OTHERS
8. BONDING
9. F
10. T
11. NG
12. T
13. F
14. D
15. I
16. E
17. H
18. A
19. C
20. PLATFORM
21. A-FRAME
22. PULLEY(S)
23. (BOAT CARRYING) TANK
24. (CAST IRON) WEIGHTS
25. FRANCE AND BELGIUM
26. A HYDRAULIC PUMP
27. CYLINDERS AND PISTONS
28. SIZE
29. NEVER
30. MISTAKE
31. PLANET
32. NARROW
33. COMPOSITION
34. DEFINING
35. C
36. A
37. B
38. C
39. A
40. D

**OUP PETER MAY TEST 3 ANSWERS**

1. B
2. H
3. J
4. D
5. B
6. C
7. E
8. H
9. D
10. G
11. B
12. T
13. NG
14. F
15. VIII
16. VII
17. IX
18. II
19. VI
20. HOUSING
21. CYLINDER
22. PINS
23. (A/THE)(TENSION) WRENCH
24. (A/THE) PICK
25. (THE) LEDGE (IN SHAFT)
26. MODERATE SECURITY
27. WAFER
28. YES
29. YES
30. NO
31. NO
32. INCREASING
33. REACH
34. AGREEMENT
35. MANUFACTURING
36. PRESSURE
37. UNWILLING
38. FAMILY-FRIENDLY
39. (ANNUAL) LEAVE
40. B

**OUP PETER MAY TEST 4 ANSWERS**

1. F
2. H
3. A
4. D
5. E
6. Y
7. N
8. NG
9. Y
10. Y
11. A LITTLE BLUE
12. A SPACESHIP
13. CESIUM GAS
14. T
15. F
16. NG
17. C
18. A
19. B
20. D
21. A
22. JOB
23. SKILLS
24. MOTIVATION
25. OPTIONS
26. COMPANY
27. FUTURE
28. IX
29. III
30. VII
31. VI
32. I
33. VIII
34. B\*
35. C\*
36. F\*
37. A
38. A
39. B
40. D